

MASTER BOOK 2019



Quello che vi apprestate a sfogliare è il nuovo catalogo del materiale elettrico di **ARTELETA**.

Un nuovo catalogo, nuovo nome, nuovi contenuti ma sempre la stessa nostra filosofia di business.

Nelle prossime pagine potrete trovare tantissimi accessori elettrici, nuovi e non, che potranno rendere più facile il vostro lavoro, più confortevole il vostro vivere quotidiano.

What you are about to browse is the new electric material catalogue by **ARTELETA**.

A new catalogue, new name, new contents but always the same business philosophy.

In the following pages you will find many electrical accessories, either new or not, to make your job easier and your day-to-day life more comfortable.

Dies ist **ARTELETA** neues Katalog, für Elektromaterial Beleuchtung und Zubehör.

Ein neuer Katalog, neue Name, neue Inhalte, aber immer unsere gleiche Business Philosophie.

Auf den folgenden Seiten findet man viele neue elektro Produkte, die Ihre Arbeit einfacher und Ihre tägliches Leben mehr komfortabler machen wird.

Lo que está a punto de ver es el nuevo catálogo de equipos eléctricos de **ARTELETA**. Un nuevo catálogo, nuevo nombre, nuevos contenidos, pero sigue siempre la misma filosofía de empresa.

En las siguientes páginas usted puede encontrar una gran cantidad de accesorios eléctricos, nuevos o no, que va hacer su trabajo más fácil y más cómoda su vida diaria.



1944-2019

75 years of experience

3 Cataloghi | Catalogues

1 Sola offerta commerciale | Single commercial offer

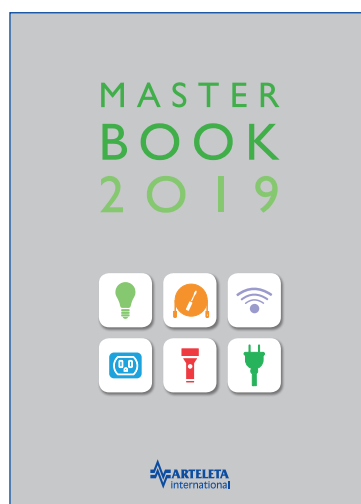

Master Book

È il catalogo "storico" del materiale elettrico, delle microlampade, dei segnalatori, delle sonde infilatufo, dei rilevatori di presenza, del materiale Berker, delle torce e lampade d'emergenza, della "spinotteria".

This is the "historical" electric material catalogue, with microlamps, signal lamps, fish tape, motion detectors, Berker material, torches and emergency lamps, plugs and sockets.



Lighting

È il catalogo dedicato all'illuminazione; in particolar modo a quella Led. Sfogliatelo ed all'interno troverete tante soluzioni innovative per l'illuminazione residenziale e del terziario. Non solo sorgenti ed apparecchi Led, ma anche fluorescenza e filamento.

This catalogue is referred to lighting: especially LED lighting. Browse it to find many innovative solutions for residential and service industry lighting. Not only LED sources and appliances, but also fluorescence and filament.

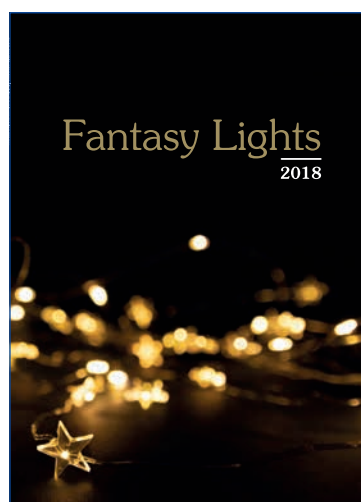

Fantasy

Decorare con la luce è da sempre stato uno dei nostri obiettivi. I prodotti di questo catalogo assolvono appieno questa missione, sia per installazioni all'interno, che all'esterno.

Decorating with light has always been one of our objectives. The products in this catalogue fully accomplish this mission, both for indoor and outdoor installation.



CONFEZIONI & MANUALI D'USO IN ITALIANO

In ottemperanza alle disposizioni del D. Lgs. 206/2005 e per fornire un valido aiuto all'installatore e/o all'utilizzatore, ARTELETA INTERNATIONAL SPA ha rinnovato la presentazione dei suoi prodotti che hanno gli imballi, i manuali e le garanzie in lingua italiana.

PACKAGE & OPERATING MANUALS IN ITALIAN

In compliance with the instructions of D. Lgs. 206/2005 and to provide valuable help to the installer and/or user, ARTELETA INTERNATIONAL spa has renovated the presentation of its products that have packaging, manuals and warranties in Italian language.



CODIFICA DEI PRODOTTI CON IL CODICE A BARRE

ARTELETA INTERNATIONAL SPA ha già da anni adottato la codifica dei propri prodotti usando il codice a barre internazionale EAN13, che rappresenta un validissimo supporto nella gestione del magazzino. Attualmente tutti i prodotti distribuiti da ARTELETA INTERNATIONAL SPA recano evidenziato questo codice, sia sul singolo prodotto che su tutti i multipli d'imballo.

CODING OF PRODUCTS WITH BAR CODE

ARTELETA INTERNATIONAL spa has already for several years implemented coding of its products using the international EAN13 bar code, which represents an invaluable help in warehouse management. Currently all products distributed by ARTELETA INTERNATIONAL spa show this code, both on the individual product and on all multiple packaging.



QR CODE

I nostri prodotti sono dotati di questa nuova tecnologia che prevede collegamenti al nostro sito per maggiori informazioni, sia commerciali che tecniche. Per visualizzare il contenuto del QR CODE è necessario possedere uno smart-phone, scaricare l'applicazione "i-nigma" dal sito www.i-nigma.com e puntare la fotocamera del cellulare su questo codice.

QR CODE

Our products are fitted with this new technology that entails connecting to our website for more information, both commercial and technical. To view the QR CODE content it is required to have a smart-phone, download the "i-nigma" application from www.i-nigma.com and aim the mobile's camera on the code.



LISTINO PREZZI SU SUPPORTO MAGNETICO

Oltre al tradizionale listino cartaceo ARTELETA INTERNATIONAL SPA è in grado di fornire, alla propria clientela che ne faccia richiesta, il listino aggiornato dei propri prodotti con tracciato standard METEL, certificato. Inoltre siamo attivi con tutte le altre funzionalità fornite dalla piattaforma METEL.

PRICE LIST ON MAGNETIC MEDIA

In addition to the traditional paper price list, ARTELETA INTERNATIONAL spa is able to supply to customers, who request it, the updated price list of its products with standard METEL tracing, certified. We are also active with all the other functions supplied by the METEL platform.

ASSISTENZA TECNICA

Il servizio di assistenza tecnico ON-LINE informa e consiglia su:

- problemi tecnici, dubbi sull'installazione;
- miglior uso dei prodotti;
- rispondenza dei prodotti a normative e leggi in vigore;
- assiste nella progettazione d'impianto e nella stesura di capitolati;

Questo servizio è attivo dal Lunedì al Giovedì dalle 8.30 alle 12.00 e dalle 14.00 alle 17.00.

Il venerdì 8.30-12.00, 14.00-16.00

al n° telefonico 0039 02.66.01.35.41

Lo stesso servizio è effettuato via fax al n° 0039 02.61.22.573 e tramite e-mail: assistentatecnica@arteleta.it

TECHNICAL SUPPORT

The ON-LINE technical support service informs and advises on:

- technical problems, doubts on installation;
- better use of the products;
- compliance of the products with standards and laws in force;
- assists in system design and drawing up tender specifications;

This service is active from Monday to Thursday from 8:30am to 12 and from 2pm to 5pm. Friday 8:30am-12, 2pm-4pm by phone at 0039 02.66.01.35.41

The same service is carried out by fax on 0039 02.61.22.573 and by e-mail: assistentatecnica@arteleta.it



COME CONTATTARCI

Telefono: 0039 02.66.01.35.41

Fax: 0039 02.61.22.573

Commerciale: vendite@arteleta.it

Amministrazione: contabilita@arteleta.it

Assistenza tecnica: assistentatecnica@arteleta.it

Comunicazione web: web@arteleta.it

Web: www.arteleta.it

HOW TO CONTACT US

Telephone: 0039 02.66.01.35.41

Fax: 0039 02.61.22.573

Sales: vendite@arteleta.it

Accounting: contabilita@arteleta.it

Technical support: assistentatecnica@arteleta.it

Webmaster: web@arteleta.it

Internet: www.arteleta.it

WWW.

Vi invitiamo a visitare il nostro sito www.arteleta.it dove potrete trovare tutte le informazioni sui nostri prodotti e servizi.

We invite you to visit our website www.arteleta.it where you will find all the information on our products and services.

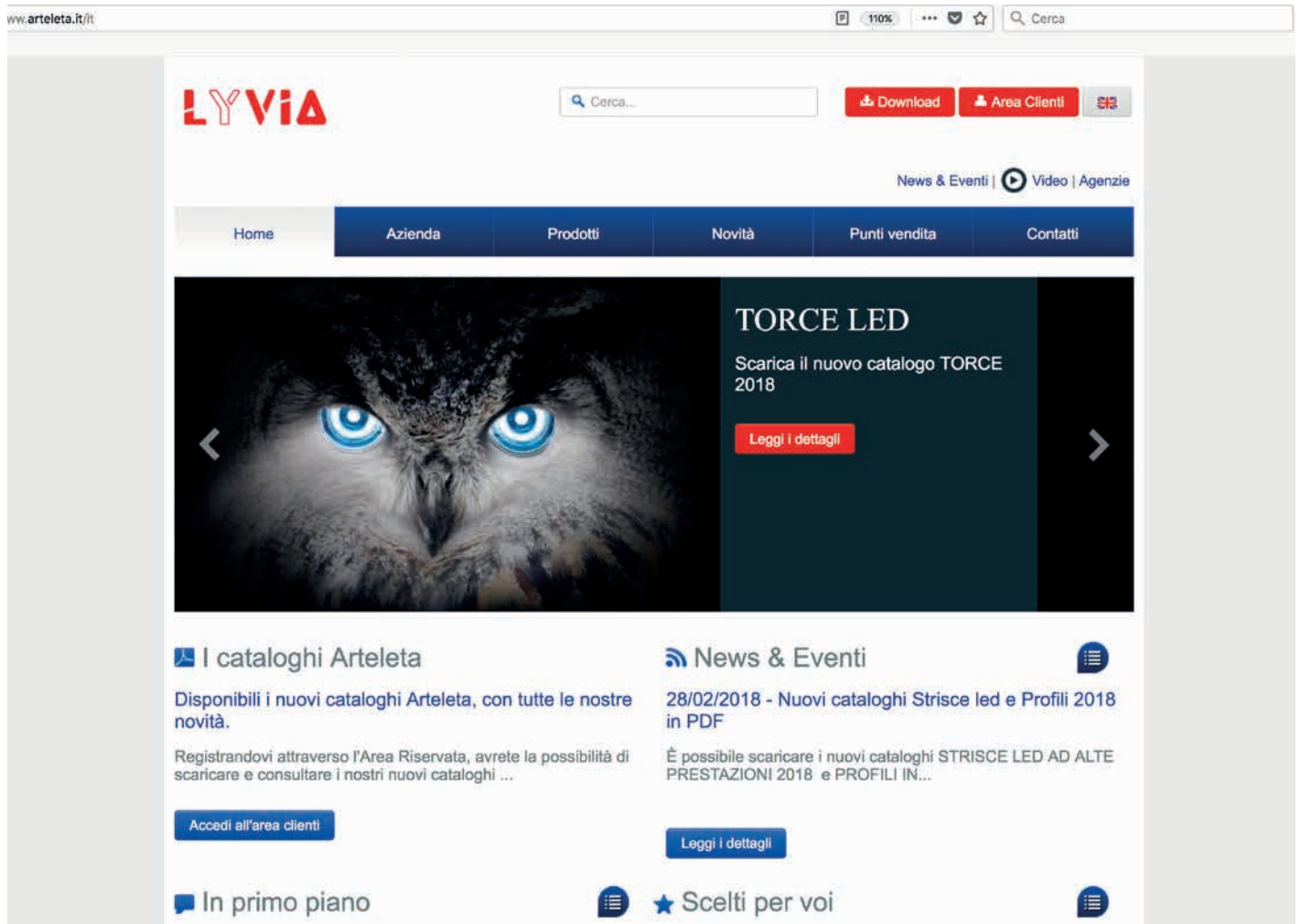

Consulta il nostro sito, ottimizzato anche in versione mobile per tablet e smartphone.

Potrai trovare:

- informazioni tecniche sui prodotti
- informazioni commerciali
- il nostro distributore più vicino a te
- video tutorial
- video e foto dei nostri prodotti
- potrai effettuare il download dei nostri cataloghi e listini
- e tanto altro ancora

Seguici anche su:



Arteleta International S.p.A.



ArteletaInt

Refer to our website, also optimised in mobile version for tablet and smartphone.

You may find:

- technical information on the products
- sales information
- the closest distributor
- video tutorials
- video and photos of our products
- you can download our catalogues and price lists
- and a lot more

Also follows us on:

ILLUMINAZIONE *LIGHTING*



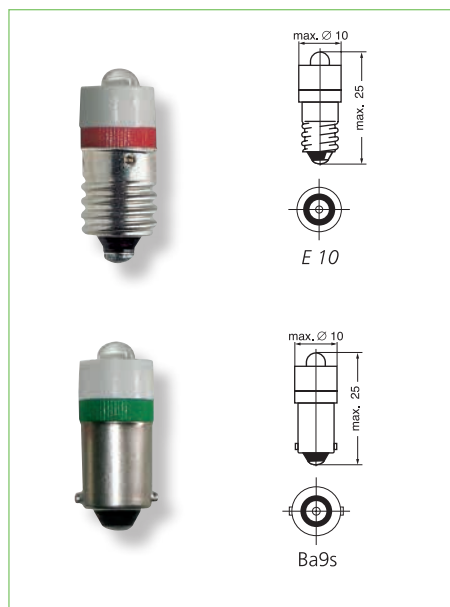

E 10 - Ba9s

Temperatura di funzionamento: $-20^{\circ} + 60^{\circ}\text{C}$
 Durata a temperatura ambiente $25^{\circ}\text{C} = > 50.000$ ore
 Angolo di diffusione: 30°

Operating temperature: $-20^{\circ} + 60^{\circ}\text{C}$
 Duration at room temperature $25^{\circ}\text{C} = > 50,000$ hours
 Beam angle: 30°

Colori disponibili:
rosso (R) verde (V) giallo (G) blu (B)
bianco (W)

Available colours:
red (R) green (V) yellow (G) blue (B)
white (W)

Applicazione dei colori per indicatori luminosi o pulsanti

Application of colours for light indicators or buttons

- rosso** = condizione di emergenza o pericolo
- verde** = condizione di sicurezza o normale
- giallo** = condizione anormale
- blu** = condizione che richiede un'azione obbligatoria
- bianco** = altre condizioni = neutro

- red** = condition of emergency or danger
- green** = condition of safety or normal
- yellow** = abnormal condition
- blue** = condition that requires an obligatory action
- white** = other conditions = neutral

T-10 x 25 E 10

Articolo Item	Volt $\pm 5\%$	mA AC / DC	Lunghezza d'onda Wavelength	Luminosità (mcd) Brightness (mcd)	Colore Colour		€
LB.1024.G	24	6 - 10	585 nm	1200	giallo yellow	10	2,08
LB.1024.B	24	6 - 10	468 nm	2500	blu blue	10	3,22
LB.1024.W	24	6 - 10	0,3x 0,3y	5000	bianco white	10	3,39
mA AC							
LB.10130.R	130	3	666 nm	1700	rosso red	10	1,99
LB.10130.V	130	3	520 nm	2500	verde green	10	3,67
LB.10130.G	130	3	585 nm	1200	giallo yellow	10	1,96
LB.10130.B	130	3	468 nm	2500	blu blue	10	3,12
LB.10130.W	130	3	0,3x 0,3y	5000	bianco white	10	3,38
LB.10240.B	240	3	468 nm	2500	blu blue	10	3,12
LB.10240.W	240	3	0,3x 0,3y	5000	bianco white	10	3,42

T-10 x 25 Ba9s

Articolo Item	Volt $\pm 5\%$	mA AC / DC	Lunghezza d'onda Wavelength	Luminosità (mcd) Brightness (mcd)	Colore Colour		€
LB.924.R	24	6 - 10	666 nm	1700	rosso red	10	2,18
LB.924.V	24	6 - 10	520 nm	2500	verde green	10	3,89
LB.924.G	24	6 - 10	585 nm	1200	giallo yellow	10	2,11
LB.924.B	24	6 - 10	468 nm	2500	blu blue	10	3,22
LB.924.W	24	6 - 10	0,3x 0,3y	5000	bianco white	10	3,42
mA AC							
LB.9130.R	130	3	666 nm	1700	rosso red	10	2,11
LB.9130.V	130	3	520 nm	2500	verde green	10	3,78
LB.9130.W	130	3	0,3x 0,3y	5000	bianco white	10	3,49
LB.9240.R	240	3	666 nm	1700	rosso red	10	2,11
LB.9240.V	240	3	520 nm	2500	verde green	10	3,78
LB.9240.G	240	3	585 nm	1200	giallo yellow	10	2,08
LB.9240.B	240	3	468 nm	2500	blu blue	10	3,22
LB.9240.W	240	3	0,3x 0,3y	5000	bianco white	10	3,49

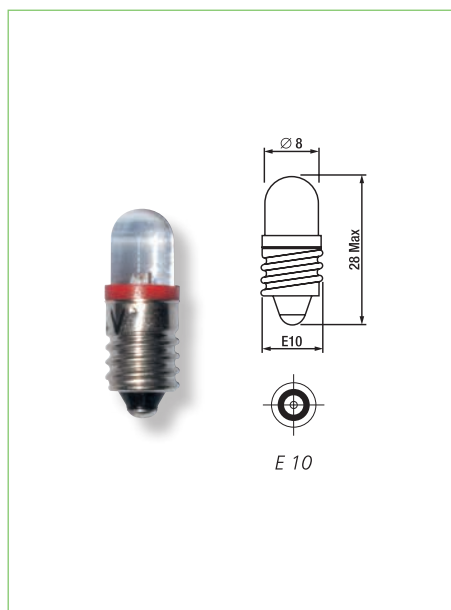

E 10

- Chip del LED protetto da lente trasparente in resina epossidica, Ø 8 mm.
- Anello in plastica dello stesso colore della luce emessa dal LED.
- Il segnale può essere usato in AC/DC; in corrente continua non è necessaria la polarizzazione del segnale.
- Angolo di diffusione: 60°

- LED Chip protected by transparent lens in epoxy resin, Ø 8 mm.
- Plastic ring in the same colour as the light emitted by the LED.
- The signal may be used in AC/DC; signal polarisation is not required in direct current.
- Beam angle: 60°

Colori disponibili:

rosso (11) verde (12) giallo (13) blu (14) bianco (15)

Available colours:

red (11) green (12) yellow (13) blue (14) white (15)



T-10 x 28

Articolo Item	Volt ± 5%	mA AC / DC	Lunghezza d'onda Wavelength	Luminosità (mcd) Brightness (mcd)	Colore Colour		€
511 012 11	12	20	625 nm	10000	rosso red	10	3,00
511 012 12	12	20	520 nm	10000	verde green	10	3,30
511 012 13	12	20	590 nm	10000	giallo yellow	10	3,00
511 012 14	12	20	470 nm	10000	blu blue	10	3,30
511 012 15	12	20	0,28x 0,29y	10000	bianco white	10	3,30
511 024 11	24/28	20	625 nm	8000	rosso red	10	3,00
511 024 12	24/28	20	520 nm	8000	verde green	10	3,30
511 024 13	24/28	20	590 nm	8000	giallo yellow	10	3,00
511 024 14	24/28	20	470 nm	8000	blu blue	10	3,30
511 024 15	24/28	20	0,28x 0,29y	8000	bianco white	10	3,30
511 048 11	48	20	625 nm	5000	rosso red	10	3,00
511 048 12	48	20	520 nm	5000	verde green	10	3,30
511 048 13	48	20	590 nm	5000	giallo yellow	10	3,00
511 048 14	48	20	470 nm	5000	blu blue	10	3,30
511 048 15	48	20	0,28x 0,29y	5000	bianco white	10	3,30
511 013 11	110/130	5	625 nm	2500	rosso red	10	3,00
511 013 12	110/130	5	520 nm	2500	verde green	10	3,30
511 013 13	110/130	5	590 nm	2500	giallo yellow	10	3,00
511 013 14	110/130	5	470 nm	2500	blu blue	10	3,30
511 013 15	110/130	5	0,28x 0,29y	2500	bianco white	10	3,30
511 023 11	230	3	625 nm	1500	rosso red	10	3,00
511 023 12	230	3	520 nm	1500	verde green	10	3,30
511 023 13	230	3	590 nm	1500	giallo yellow	10	3,00
511 023 14	230	3	470 nm	1500	blu blue	10	3,30
511 023 15	230	3	0,28x 0,29y	1500	bianco white	10	3,30

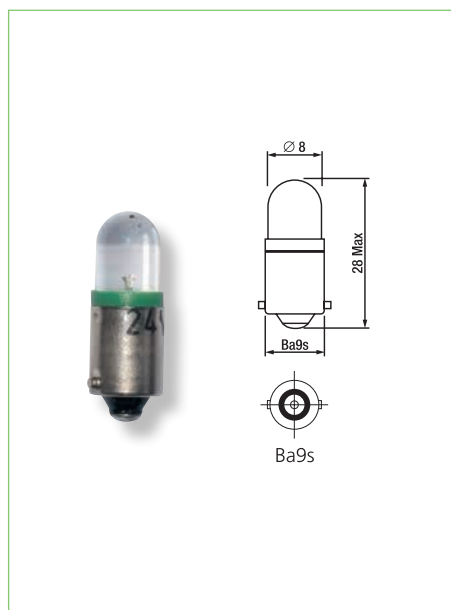

Ba9s

- Chip del LED protetto da lente trasparente in resina epossidica, Ø 8 mm.
- Anello in plastica dello stesso colore della luce emessa dal LED.
- Il segnale può essere usato in AC/DC; in corrente continua non è necessaria la polarizzazione del segnale.
- Angolo di diffusione: 60°

- LED Chip protected by transparent lens in epoxy resin, Ø 8 mm.
- Plastic ring in the same colour as the light emitted by the LED.
- The signal may be used in AC/DC; signal polarisation is not required in direct current.
- Beam angle: 60°

Colori disponibili:

rosso (11) verde (12) giallo (13) blu (14) bianco (15)

Available colours:

red (11) green (12) yellow (13) blue (14) white (15)



T-10 x 28

Articolo Item	Volt ± 5%	mA AC / DC	Lunghezza d'onda Wavelength	Luminosità (mcd) Brightness (mcd)	Colore Colour		€
520 912 11	12	20	625 nm	10000	rosso red	10	2,94
520 912 12	12	20	520 nm	10000	verde green	10	3,23
520 912 13	12	20	590 nm	10000	giallo yellow	10	2,94
520 912 14	12	20	470 nm	10000	blu blue	10	3,23
520 912 15	12	20	0,28x 0,29y	10000	bianco white	10	3,23
520 924 11	24/28	20	625 nm	8000	rosso red	10	2,94
520 924 12	24/28	20	520 nm	8000	verde green	10	3,23
520 924 13	24/28	20	590 nm	8000	giallo yellow	10	2,94
520 924 14	24/28	20	470 nm	8000	blu blue	10	3,23
520 924 15	24/28	20	0,28x 0,29y	8000	bianco white	10	3,23
520 948 11	48	20	625 nm	5000	rosso red	10	2,94
520 948 12	48	20	520 nm	5000	verde green	10	3,23
520 948 13	48	20	590 nm	5000	giallo yellow	10	2,94
520 948 14	48	20	470 nm	5000	blu blue	10	3,23
520 948 15	48	20	0,28x 0,29y	5000	bianco white	10	3,23
520 913 11	110/130	5	625 nm	2500	rosso red	10	2,94
520 913 12	110/130	5	520 nm	2500	verde green	10	3,23
520 913 13	110/130	5	590 nm	2500	giallo yellow	10	2,94
520 913 14	110/130	5	470 nm	2500	blu blue	10	3,23
520 913 15	110/130	5	0,28x 0,29y	2500	bianco white	10	3,23
520 923 11	230	3	625 nm	1500	rosso red	10	2,94
520 923 12	230	3	520 nm	1500	verde green	10	3,23
520 923 13	230	3	590 nm	1500	giallo yellow	10	2,94
520 923 14	230	3	470 nm	1500	blu blue	10	3,23
520 923 15	230	3	0,28x 0,29y	1500	bianco white	10	3,23

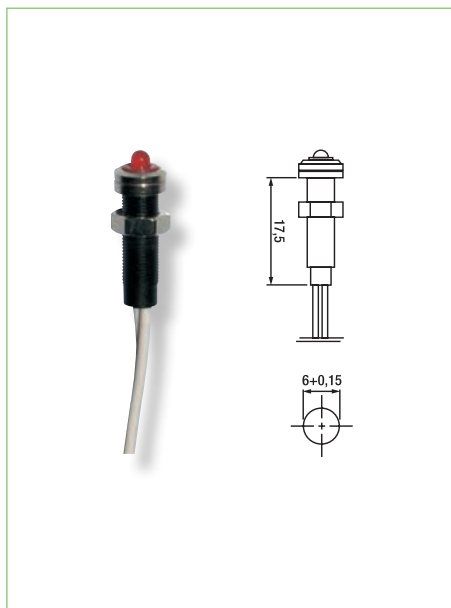

Ø 6 mm

Corpo cilindrico filettato - nero - policarbonato
 Rondella di fissaggio
 Ghiera cromata Ø 8 mm
 Cavetti PVC 0,50 mm² - lunghezza 200 mm
 LED Ø 3 mm

*Threaded cylindrical body - black - polycarbonate
 Fixing washer
 Chrome plated ring Ø 8 mm
 Cables PVC 0.50 mm² - length 200 mm
 LED Ø 3 mm*



Articolo Item	Volt ± 5%	mA AC / DC	Lunghezza d'onda Wavelength	Luminosità (mcd) Brightness (mcd)	Colore Colour		€
500 612 11	12	20	625 nm	3000	rosso red	10	3,01
500 612 12	12	20	520 nm	3000	verde green	10	3,40
500 612 13	12	20	590 nm	3000	giallo yellow	10	3,01
500 612 14	12	20	470 nm	3000	blu blue	10	3,40
500 612 15	12	20	0,28x 0,29y	3000	bianco white	10	3,40
500 624 11	24/28	20	625 nm	2400	rosso red	10	3,01
500 624 12	24/28	20	520 nm	2400	verde green	10	3,40
500 624 13	24/28	20	590 nm	2400	giallo yellow	10	3,01
500 624 14	24/28	20	470 nm	2400	blu blue	10	3,40
500 624 15	24/28	20	0,28x 0,29y	2400	bianco white	10	3,40
500 648 11	48	20	625 nm	1500	rosso red	10	3,01
500 648 12	48	20	520 nm	1500	verde green	10	3,40
500 648 13	48	20	590 nm	1500	giallo yellow	10	3,01
500 648 14	48	20	470 nm	1500	blu blue	10	3,40
500 648 15	48	20	0,28x 0,29y	1500	bianco white	10	3,40
500 613 11	110/130	5	625 nm	750	rosso red	10	3,01
500 613 12	110/130	5	520 nm	750	verde green	10	3,40
500 613 13	110/130	5	590 nm	750	giallo yellow	10	3,01
500 613 14	110/130	5	470 nm	750	blu blue	10	3,40
500 613 15	110/130	5	0,28x 0,29y	750	bianco white	10	3,40
500 623 11	230	3	625 nm	450	rosso red	10	3,01
500 623 12	230	3	520 nm	450	verde green	10	3,40
500 623 13	230	3	590 nm	450	giallo yellow	10	3,01
500 623 14	230	3	470 nm	450	blu blue	10	3,40
500 623 15	230	3	0,28x 0,29y	450	bianco white	10	3,40

Ø 8 mm

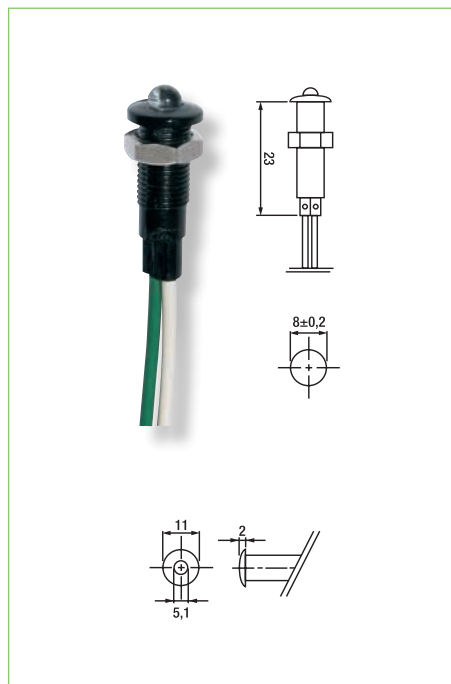

Corpo cilindrico filettato - nero - polycarbonato
 Rondella di fissaggio
 Ghiera nera Ø 11 mm
 Cavetti PVC 0,50 mm² - lunghezza 200 mm
 LED Ø 5 mm

Threaded cylindrical body - black - polycarbonate
Fixing washer
Black ring Ø 11 mm
Cables PVC 0.50 mm² - length 200 mm
LED Ø 5 mm



Articolo Item	Volt ± 5%	mA AC / DC	Lunghezza d'onda Wavelength	Luminosità (mcd) Brightness (mcd)	Colore Colour		€
500 812 11	12	20	625 nm	3000	rosso red	10	3,10
500 812 12	12	20	520 nm	3000	verde green	10	3,51
500 812 13	12	20	590 nm	3000	giallo yellow	10	3,10
500 812 14	12	20	470 nm	3000	blu blue	10	3,51
500 812 15	12	20	0,28x 0,29y	3000	bianco white	10	3,51
500 824 11	24/28	20	625 nm	2400	rosso red	10	3,10
500 824 12	24/28	20	520 nm	2400	verde green	10	3,51
500 824 13	24/28	20	590 nm	2400	giallo yellow	10	3,10
500 824 14	24/28	20	470 nm	2400	blu blue	10	3,51
500 824 15	24/28	20	0,28x 0,29y	2400	bianco white	10	3,51
500 848 11	48	20	625 nm	1500	rosso red	10	3,10
500 848 12	48	20	520 nm	1500	verde green	10	3,51
500 848 13	48	20	590 nm	1500	giallo yellow	10	3,10
500 848 14	48	20	470 nm	1500	blu blue	10	3,51
500 848 15	48	20	0,28x 0,29y	1500	bianco white	10	3,51
500 813 11	110/130	5	625 nm	750	rosso red	10	3,10
500 813 12	110/130	5	520 nm	750	verde green	10	3,51
500 813 13	110/130	5	590 nm	750	giallo yellow	10	3,10
500 813 14	110/130	5	470 nm	750	blu blue	10	3,51
500 813 15	110/130	5	0,28x 0,29y	750	bianco white	10	3,51
500 823 11	230	3	625 nm	450	rosso red	10	3,10
500 823 12	230	3	520 nm	450	verde green	10	3,51
500 823 13	230	3	590 nm	450	giallo yellow	10	3,10
500 823 14	230	3	470 nm	450	blu blue	10	3,51
500 823 15	230	3	0,28x 0,29y	450	bianco white	10	3,51

Indicatori luminosi

Light indicators

LYVIA

CE

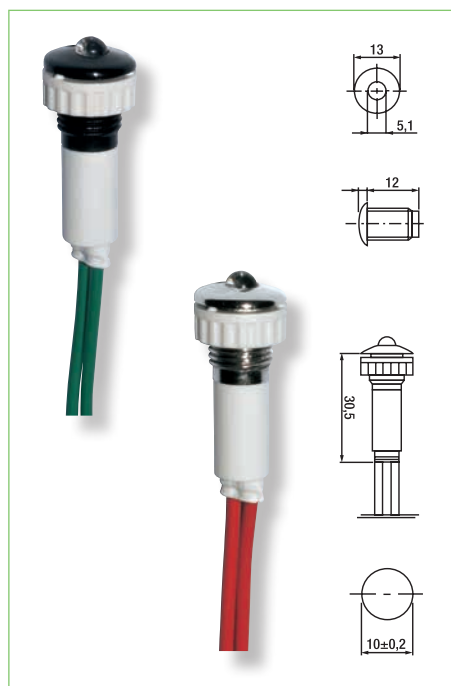

Ø 10 mm

Corpo cilindrico filettato - policarbonato
Rondella di fissaggio
Ghiera cromata bassa Ø 13 mm
Cavetti PVC 0,50 mm² - lunghezza 200 mm
LED Ø 5 mm

Threaded cylindrical body - polycarbonate
Fixing washer
Low chrome plated ring Ø 13 mm
Cables PVC 0.50 mm² - length 200 mm
LED Ø 5 mm



Articolo Item	Volt ± 5%	mA AC / DC	Lunghezza d'onda Wavelength	Luminosità (mcd) Brightness (mcd)	Colore Colour		€
501 012 11	12	20	625 nm	3000	rosso red	10	3,01
501 012 12	12	20	520 nm	3000	verde green	10	3,40
501 012 13	12	20	590 nm	3000	giallo yellow	10	3,01
501 012 14	12	20	470 nm	3000	blu blue	10	3,40
501 012 15	12	20	0,28x 0,29y	3000	bianco white	10	3,40
501 024 11	24/28	20	625 nm	2400	rosso red	10	3,01
501 024 12	24/28	20	520 nm	2400	verde green	10	3,40
501 024 13	24/28	20	590 nm	2400	giallo yellow	10	3,01
501 024 14	24/28	20	470 nm	2400	blu blue	10	3,40
501 024 15	24/28	20	0,28x 0,29y	2400	bianco white	10	3,40
501 048 11	48	20	625 nm	1500	rosso red	10	3,01
501 048 12	48	20	520 nm	1500	verde green	10	3,40
501 048 13	48	20	590 nm	1500	giallo yellow	10	3,01
501 048 14	48	20	470 nm	1500	blu blue	10	3,40
501 048 15	48	20	0,28x 0,29y	1500	bianco white	10	3,40
501 013 11	110/130	5	625 nm	750	rosso red	10	3,01
501 013 12	110/130	5	520 nm	750	verde green	10	3,40
501 013 13	110/130	5	590 nm	750	giallo yellow	10	3,01
501 013 14	110/130	5	470 nm	750	blu blue	10	3,40
501 013 15	110/130	5	0,28x 0,29y	750	bianco white	10	3,40
501 023 11	230	3	625 nm	450	rosso red	10	3,01
501 023 12	230	3	520 nm	450	verde green	10	3,40
501 023 13	230	3	590 nm	450	giallo yellow	10	3,01
501 023 14	230	3	470 nm	450	blu blue	10	3,40
501 023 15	230	3	0,28x 0,29y	450	bianco white	10	3,40

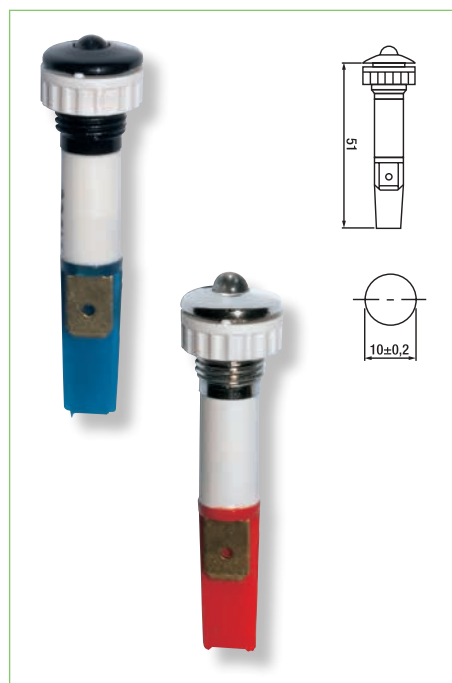

Ø 10 mm

FASTON

Corpo cilindrico filettato - policarbonato
Rondella di fissaggio
Ghiera cromata bassa Ø 13 mm
Supporto faston 6,3x0,8 mm
LED Ø 5 mm

FASTON

*Threaded cylindrical body
Fixing washer
Low chrome plated ring Ø 13 mm
Faston support 6.3x0.8 mm
LED Ø 5 mm*



Articolo Item	Volt ± 5%	mA AC / DC	Lunghezza d'onda Wavelength	Luminosità (mcd) Brightness (mcd)	Colore Colour		€
561 012 11	12	20	625 nm	3000	rosso red	10	3,27
561 012 12	12	20	520 nm	3000	verde green	10	3,70
561 012 13	12	20	590 nm	3000	giallo yellow	10	3,27
561 012 14	12	20	470 nm	3000	blu blue	10	3,70
561 012 15	12	20	0,28x 0,29y	3000	bianco white	10	3,70
561 024 11	24/28	20	625 nm	2400	rosso red	10	3,27
561 024 12	24/28	20	520 nm	2400	verde green	10	3,70
561 024 13	24/28	20	590 nm	2400	giallo yellow	10	3,27
561 024 14	24/28	20	470 nm	2400	blu blue	10	3,70
561 024 15	24/28	20	0,28x 0,29y	2400	bianco white	10	3,70
561 048 11	48	20	625 nm	1500	rosso red	10	3,27
561 048 12	48	20	520 nm	1500	verde green	10	3,70
561 048 13	48	20	590 nm	1500	giallo yellow	10	3,27
561 048 14	48	20	470 nm	1500	blu blue	10	3,70
561 048 15	48	20	0,28x 0,29y	1500	bianco white	10	3,70
561 013 11	110/130	5	625 nm	750	rosso red	10	3,27
561 013 12	110/130	5	520 nm	750	verde green	10	3,70
561 013 13	110/130	5	590 nm	750	giallo yellow	10	3,27
561 013 14	110/130	5	470 nm	750	blu blue	10	3,70
561 013 15	110/130	5	0,28x 0,29y	750	bianco white	10	3,70
561 023 11	230	3	625 nm	450	rosso red	10	3,27
561 023 12	230	3	520 nm	450	verde green	10	3,70
561 023 13	230	3	590 nm	450	giallo yellow	10	3,27
561 023 14	230	3	470 nm	450	blu blue	10	3,70
561 023 15	230	3	0,28x 0,29y	450	bianco white	10	3,70

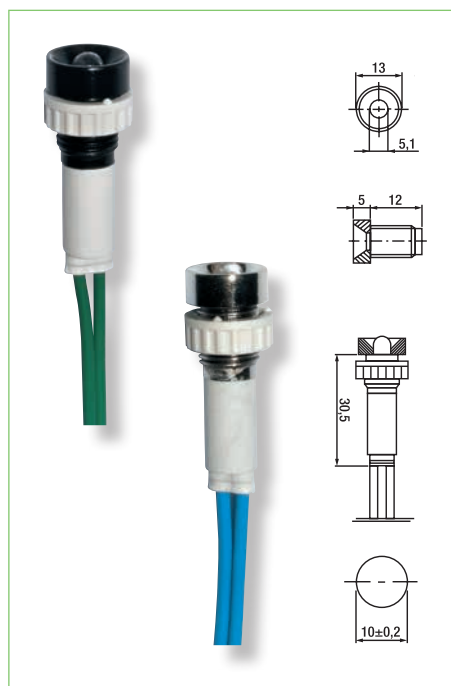

Ø 10 mm

Corpo cilindrico filettato - polycarbonato
 Rondella di fissaggio
 Ghiera cromata alta Ø 13 mm
 Cavetti PVC 0,50 mm² - lunghezza 200 mm
 LED Ø 5 mm

*Threaded cylindrical body - polycarbonate
 Fixing washer
 High chrome plated ring Ø 13 mm
 Cables PVC 0.50 mm² - length 200 mm
 LED Ø 5 mm*



Articolo Item	Volt ± 5%	mA AC / DC	Lunghezza d'onda Wavelength	Luminosità (mcd) Brightness (mcd)	Colore Colour		€
601 012 11	12	20	625 nm	3000	rosso red	10	3,27
601 012 12	12	20	520 nm	3000	verde green	10	3,70
601 012 13	12	20	590 nm	3000	giallo yellow	10	3,27
601 012 14	12	20	470 nm	3000	blu blue	10	3,70
601 012 15	12	20	0,28x 0,29y	3000	bianco white	10	3,70
601 024 11	24/28	20	625 nm	2400	rosso red	10	3,27
601 024 12	24/28	20	520 nm	2400	verde green	10	3,70
601 024 13	24/28	20	590 nm	2400	giallo yellow	10	3,27
601 024 14	24/28	20	470 nm	2400	blu blue	10	3,70
601 024 15	24/28	20	0,28x 0,29y	2400	bianco white	10	3,70
601 048 11	48	20	625 nm	1500	rosso red	10	3,27
601 048 12	48	20	520 nm	1500	verde green	10	3,70
601 048 13	48	20	590 nm	1500	giallo yellow	10	3,27
601 048 14	48	20	470 nm	1500	blu blue	10	3,70
601 048 15	48	20	0,28x 0,29y	1500	bianco white	10	3,70
601 013 11	110/130	5	625 nm	750	rosso red	10	3,27
601 013 12	110/130	5	520 nm	750	verde green	10	3,70
601 013 13	110/130	5	590 nm	750	giallo yellow	10	3,27
601 013 14	110/130	5	470 nm	750	blu blue	10	3,70
601 013 15	110/130	5	0,28x 0,29y	750	bianco white	10	3,70
601 023 11	230	3	625 nm	450	rosso red	10	3,27
601 023 12	230	3	520 nm	450	verde green	10	3,70
601 023 13	230	3	590 nm	450	giallo yellow	10	3,27
601 023 14	230	3	470 nm	450	blu blue	10	3,70
601 023 15	230	3	0,28x 0,29y	450	bianco white	10	3,70

Indicatori luminosi

Light indicators

LYVIA

CE

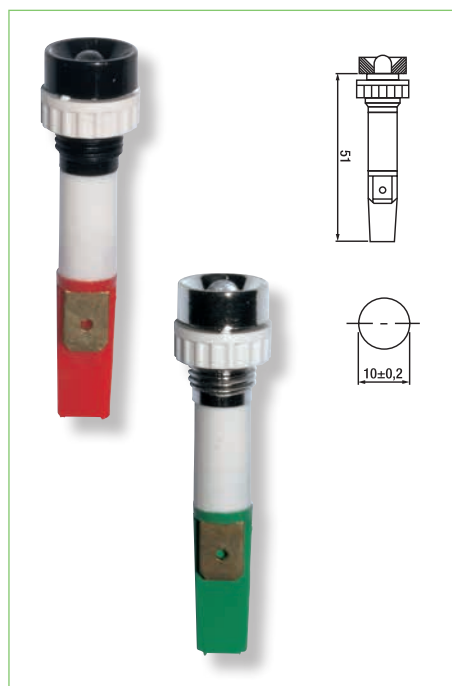

Ø 10 mm

FASTON

Corpo cilindrico filettato - polycarbonato
Rondella di fissaggio
Ghiera cromata alta Ø 13 mm
Supporto faston 6,3x0,8 mm
LED Ø 5 mm

FASTON

Threaded cylindrical body - polycarbonate
Fixing washer
High chrome plated ring Ø 13 mm
Faston support 6.3x0.8 mm
LED Ø 5 mm



Articolo Item	Volt ± 5%	mA AC / DC	Lunghezza d'onda Wavelength	Luminosità (mcd) Brightness (mcd)	Colore Colour		€
661 012 11	12	20	625 nm	3000	rosso red	10	3,37
661 012 12	12	20	520 nm	3000	verde green	10	3,81
661 012 13	12	20	590 nm	3000	giallo yellow	10	3,37
661 012 14	12	20	470 nm	3000	blu blue	10	3,81
661 012 15	12	20	0,28x 0,29y	3000	bianco white	10	3,81
661 024 11	24/28	20	625 nm	2400	rosso red	10	3,37
661 024 12	24/28	20	520 nm	2400	verde green	10	3,81
661 024 13	24/28	20	590 nm	2400	giallo yellow	10	3,37
661 024 14	24/28	20	470 nm	2400	blu blue	10	3,81
661 024 15	24/28	20	0,28x 0,29y	2400	bianco white	10	3,81
661 048 11	48	20	625 nm	1500	rosso red	10	3,37
661 048 12	48	20	520 nm	1500	verde green	10	3,81
661 048 13	48	20	590 nm	1500	giallo yellow	10	3,37
661 048 14	48	20	470 nm	1500	blu blue	10	3,81
661 048 15	48	20	0,28x 0,29y	1500	bianco white	10	3,81
661 013 11	110/130	5	625 nm	750	rosso red	10	3,37
661 013 12	110/130	5	520 nm	750	verde green	10	3,81
661 013 13	110/130	5	590 nm	750	giallo yellow	10	3,37
661 013 14	110/130	5	470 nm	750	blu blue	10	3,81
661 013 15	110/130	5	0,28x 0,29y	750	bianco white	10	3,81
661 023 11	230	3	625 nm	450	rosso red	10	3,37
661 023 12	230	3	520 nm	450	verde green	10	3,81
661 023 13	230	3	590 nm	450	giallo yellow	10	3,37
661 023 14	230	3	470 nm	450	blu blue	10	3,81
661 023 15	230	3	0,28x 0,29y	450	bianco white	10	3,81



TUBOLARI | TUBULAR

- Diffusore in vetro
- Virola nichelata

- Glass diffuser
- Nickel plated ferrule

T-9 x 23 E 10

Articolo Item	Volt	mA	Watt	Filamento Filament		€
F.10.23.12	12	165	2	C-2V	100	0,33
F.10.23.14	14	140	2	C-2V	100	0,34
F.10.23.24	24	80	2	C-2F	100	0,36
F.10.23.24.3	24	125	3	C-2F	100	0,36
F.10.23.30	30	65	2	C-2F	100	0,36
F.10.23.36	36	50	2	C-2F	100	0,39
F.10.23.60	60	33	2	C-2F	100	0,52
F.10.23.110	110	18	2	CC-3	100	0,93
F.10.23.220	220	14	3	C-7A	100	1,69

T-9 x 23 Ba9s

Articolo Item	Volt	mA	Watt	Filamento Filament		€
Ba.9.23.6	6	330	2	C-2V	100	0,32
Ba.9.23.12	12	165	2	C-2V	100	0,35
Ba.9.23.24	24	80	2	C-2F	100	0,35
Ba.9.23.24.3	24	125	3	C-2F	100	0,35
Ba.9.23.30	30	65	2	C-2F	100	0,35
Ba.9.23.36	36	50	2	C-2F	100	0,40
Ba.9.23.48	48	40	2	C-2F	100	0,50
Ba.9.23.60	60	33	2	C-2F	100	0,55
Ba.9.23.110	110	18	2	CC-3	100	1,20
Ba.9.23.130	130	20	2,6	CC-3	100	1,20
Ba.9.23.220	220	14	3	C-7A	100	1,78
Ba.9.23.240	240	12	3	C-7A	100	1,80

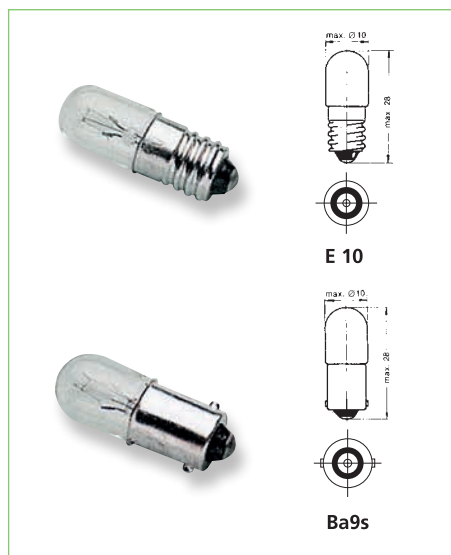

TUBOLARI | TUBULAR

- Diffusore in vetro
- Virola nichelata

- Glass diffuser
- Nickel plated ferrule

T-10 x 28 E 10

Articolo Item	Volt	mA	Watt	Filamento Filament		€
F.10.6.2	6	330	2	C-2V	100	0,34
F.10.12.2	12	165	2	C-2V	100	0,34
F.10.14.2	14	140	2	C-2V	100	0,34
F.10.24.2	24	80	2	C-2F	100	0,36
F.10.24.3	24	125	3	C-2F	100	0,36
F.10.30.2	30	65	2	C-2F	100	0,37
F.10.30.3	30	100	3	C-2F	100	0,37
F.10.36.3	36	84	3	C-2F	100	0,39
F.10.48.3	48	63	3	C-2F	100	0,46
F.10.60.3	CE 60	50	3	C-2F	100	0,52
F.10.110.2	CE 110	18	2	C-5A	100	0,94
F.10.110.3	CE 110	27	3	C-5A	100	0,94
F.10.130.2.6	CE 130	20	2,6	C-5A	100	1,00
F.10.220.3	CE 220	14	3	C-7A	100	1,48
F.10.240.3	CE 240	12	3	C-7A	100	1,48

T-10 x 28 Ba9s

Articolo Item	Volt	mA	Watt	Filamento Filament		€
Ba.9.6	6	330	2	C-2V	100	0,33
Ba.9.12	12	165	2	C-2V	100	0,31
Ba.9.12.3	12	250	3	C-2V	100	0,31
Ba.9.24.1.2	24	50	1,2	C-2F	100	0,34
Ba.9.24.2	24	80	2	C-2F	100	0,34
Ba.9.24.3	24	125	3	C-2F	100	0,34
Ba.9.30.2	30	65	2	C-2F	100	0,34
Ba.9.30.3	30	100	3	C-2F	100	0,34
Ba.9.36.2	36	50	2	C-2F	100	0,39
Ba.9.36.3	36	84	3	C-2F	100	0,39
Ba.9.48.2	48	40	2	C-2F	100	0,48
Ba.9.60.2	CE 60	33	2	C-2F	100	0,54
Ba.9.60.3	CE 60	50	3	C-2F	100	0,54
Ba.9.110.2	CE 110	18	2	C-5A	100	1,04
Ba.9.110.3	CE 110	27	3	C-5A	100	1,04
Ba.9.130.2	CE 130	15	2	C-5A	100	1,04
Ba.9.130.2.6	CE 130	20	2,6	C-5A	100	1,04
Ba.9.160	CE 160	18	3	C-5A	100	1,04
Ba.9.220	CE 220	14	3	C-7A	100	1,48
Ba.9.240	CE 240	12	3	C-7A	100	1,61

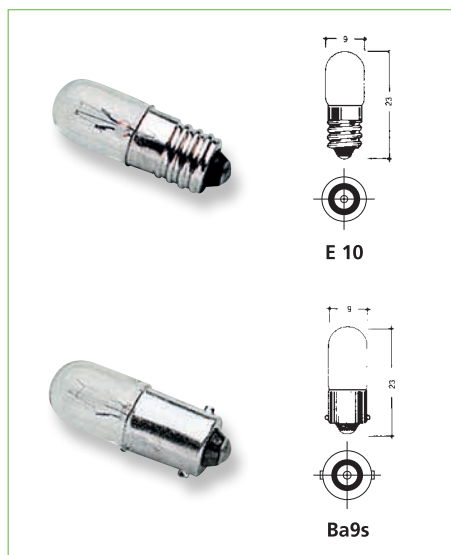

TUBOLARI | TUBULAR

Medesime lampadine delle pagine precedenti.
Imballo in pratici astucci da 10 pz.

Same lamps as the previous pages.
Packaging in handy 10-pcs cases.



T-9 x 23 E 10

Articolo Item	Volt	mA	Watt	Filamento Filament		€
E23.10.122	12	165	2	C-2V	10	0,41
E23.10.242	24	80	2	C-2F	10	0,43
E23.10.243	24	125	3	C-2F	10	0,43
E23.10.30	30	65	2	C-2F	10	0,43
E23.10.220	CE 220	14	3	C-7A	10	2,08

T-9 x 23 Ba9s

Articolo Item	Volt	mA	Watt	Filamento Filament		€
B23.10.12	12	165	2	C-2V	10	0,44
B23.10.242	24	80	2	C-2F	10	0,44
B23.10.243	24	125	3	C-2F	10	0,44
B23.10.362	36	50	2	C-2F	10	0,44
B23.10.130	CE 130	20	2,6	CC-3	10	1,28
B23.10.220	CE 220	14	3	C-7A	10	2,13

T-10 x 28 E 10

Articolo Item	Volt	mA	Watt	Filamento Filament		€
E.10.122	12	165	2	C-2V	10	0,41
E.10.142	14	140	2	C-2V	10	0,43
E.10.242	24	80	2	C-2F	10	0,43
E.10.243	24	125	3	C-2F	10	0,43
E.10.302	30	65	2	C-2F	10	0,43
E.10.303	30	100	3	C-2F	10	0,43
E.10.2203	CE 220	14	3	C-7A	10	1,74

T-10 x 28 Ba9s

Articolo Item	Volt	mA	Watt	Filamento Filament		€
B.10.122	12	165	2	C-2V	10	0,44
B.10.123	12	250	3	C-2V	10	0,44
B.10.242	24	80	2	C-2F	10	0,44
B.10.243	24	125	3	C-2F	10	0,44
B.10.302	30	65	2	C-2F	10	0,44
B.10.303	30	100	3	C-2F	10	0,44
B.10.362	36	50	2	C-2F	10	0,44
B.10.363	36	84	3	C-2F	10	0,44
B.10.482	48	40	2	C-2F	10	0,56
B.10.1102	CE 110	18	2	C-5A	10	1,20
B.10.1103	CE 110	27	3	C-5A	10	1,20
B.10.13026	CE 130	20	2,6	C-5A	10	1,20
B.10.2203	CE 220	14	3	C-7A	10	1,79
B.10.240	CE 240	12	3	C-7A	10	1,79

TUBOLARI | TUBULAR

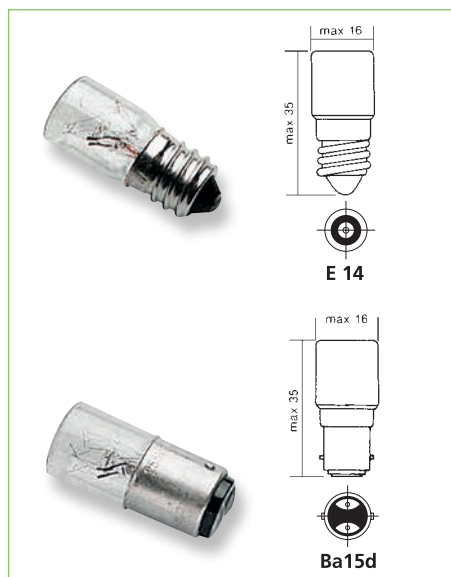

- Diffusore in vetro
- Virola nichelata

- Glass diffuser
- Nickel plated ferrule

T-16 x 35 E 14

Articolo Item	Volt	Watt	Filamento Filament		€
LIR.34.24	24	5	C-2V	50	0,74
LIR.34.60	60	5	C-3A	50	0,74
LIR.34.220	220	5	C-7A	50	1,56
LIR.34.260	260	5	C-7A	50	1,45

T-16 x 35 Ba15d

Articolo Item	Volt	Watt	Filamento Filament		€
LIR.35.24	24	5	C-2V	50	0,68
LIR.35.30	30	5	C-2V	50	0,68
LIR.35.130	130	5	C-5A	50	1,06
LIR.35.220	220	5	C-7A	50	1,45

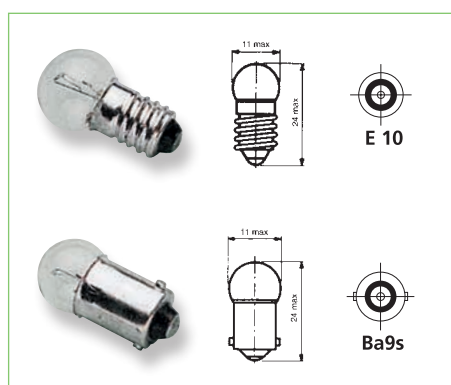

SFERETTA | SMALL SPHERE

- Diffusore in vetro
- Virola nichelata

- Glass diffuser
- Nickel plated ferrule

G-11 x 23 E 10

Articolo Item	Volt	mA	Watt	Filamento Filament		€
SF.10.6	6	330	2	C-2R	25	0,24
SF.10.12	12	165	2	C-2V	25	0,27
SF.10.24	24	80	2	C-2F	25	0,31
SF.10.30	30	65	2	C-2F	25	0,31

G-11 x 23 Ba9s

Articolo Item	Volt	mA	Watt	Filamento Filament		€
SF.9.12	12	165	2	C-2V	100	0,24
SF.9.24	24	80	2	C-2F	25	0,31

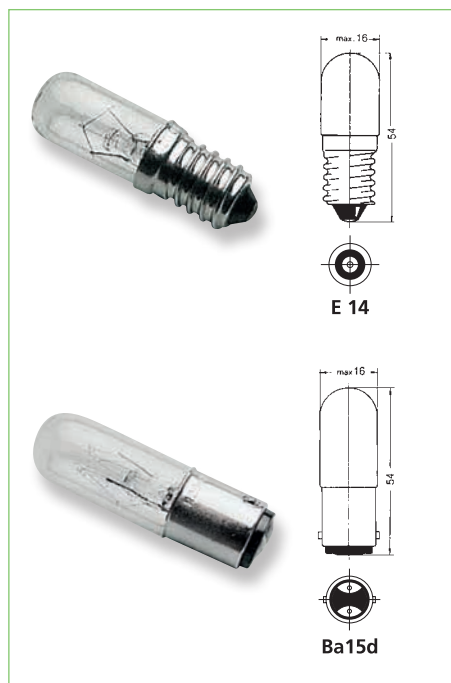

TUBOLARI LUNGHE | LONG TUBULAR

- Diffusore in vetro
- Virola nichelata

- Glass diffuser
- Nickel plated ferrule

T-16 x 54 E 14

Articolo Item	Volt	mA	Watt	Filamento Filament		€
1754.12	12	250	3	C-2R	50	0,59
1754.24	24	125	3	C-2F	50	0,59
1754.30	30	100	3	C-2F	50	0,59
1754.48	48	60	3	C-3A	50	0,69
1754.60	€ € 60	85	5	C-5A	50	0,69
1754.110	€ € 110	90	10	C-5A	50	0,80
1754.130	€ € 130	80	10	C-5A	50	0,80
1754.160	€ € 160	60	10	C-5A	50	0,80
1754.220	€ € 220	45	10	C-7A	50	0,97
1754.240	€ € 240	40	10	C-7A	50	0,97
1754.260	€ € 260	40	10	C-7A	50	0,97
1754.380	€ € 380	25	10	C-5A	50	1,37

T-16 x 54 Ba15d

Articolo Item	Volt	mA	Watt	Filamento Filament		€
1755.24	24	125	3	C-2F	50	0,72
1755.160	€ € 160	60	10	C-5A	50	0,86
1755.220	€ € 220	45	10	C-7A	50	1,08
1755.240	€ € 240	40	10	C-7A	50	1,08
1755.380	€ € 380	25	10	C-5A	50	1,44

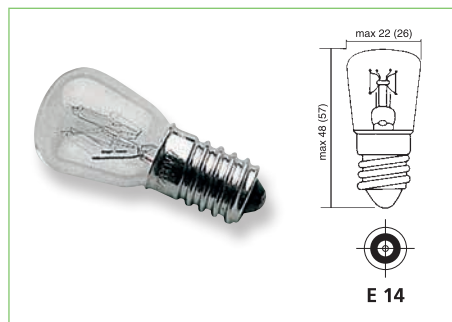

PICCOLA PERA | SMALL PEAR

- Diffusore in vetro
- Virola nichelata
- Glass diffuser
- Nickel plated ferrule



T-22 x 48 E 14

Articolo Item		Volt	Watt	Filamento Filament		€
5320.110	€ €	110	15	C-7A	50	0,45
5314	• per forni (300°C) • for ovens (300°C) € €	230	15	C-7A	25	1,04

T-26 x 57 E 14

Articolo Item		Volt	Watt	Filamento Filament		€
5320	• per frigoriferi • for refrigerators € €	230	15	C-7A	25	0,70



WEDGE W 2 x 4,6 d

- per frigoriferi
- for refrigerators

T-5 x 20

Articolo Item	Volt	Watt	Filamento Filament	Flusso MSCP MSCP Flux	Ore Hours		€
22.46.528	28	1,12	C-2F	0,3	7.000	100	0,52

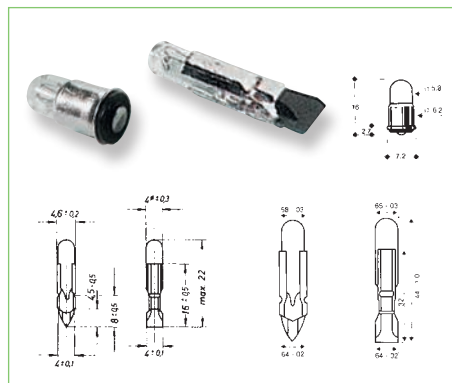

TELEFONICHE | TELEPHONE

T 4,6 subliput Ø 4 x 22

Articolo Item	Volt	mA	Flusso MSCP MSCP Flux		€
46.06.020	6	20	.024	50	0,71

T 6,8 standard Ø 6 x 44

Articolo Item	Volt	mA	Flusso MSCP MSCP Flux		€
68.06.040	6	40	.048	50	0,71
68.48.020	48	20	.160	50	0,76

T- 1 3/4 midget flanged Ø 7 x 16

Articolo Item	Volt	mA	Flusso MSCP MSCP Flux		€
94.14.080	14	80	.300	100	0,25
94.60.020	€ € 60	20	.150	100	0,40

Lampade nane a filamento per torce

Miniature filament lamps for torches



G-11 x 23

Articolo Item	Tipo Type	Volt	A.		€
S.600	Sferetta Small sphere	1,5	0.20	25	0,23
S.603	Sferetta Small sphere	2,5	0.20	25	0,20
S.605	Sferetta Small sphere	3,5	0.20	25	0,20
S.601	Sferetta Small sphere	4,8	0.30	25	0,23
S.602	Sferetta Small sphere	6	0.30	25	0,23
S.606	Sferetta Small sphere	12	0.25	25	0,23



P 13,5 S

Articolo Item	Tipo Type	Volt	A.		€
S.614	Prefocus	2,5	0.50	25	0,25
S.615	Prefocus	3,5	0.50	25	0,25
S.617	Prefocus	4,8	0.50	25	0,25
S.616	Prefocus	6	0.50	25	0,25
58790	Alogena Halogen Philips HPR 71*	6	1.66	5	6,97
59007	Alogena Halogen Philips HPR 71*	6	1.66	5	4,69

* Lampadine di ricambio per lanterne di emergenza art. GW.2003, art. GW.4000 e art. GW.6000 (vecchi modelli).

* Spare bulbs for emergency lanterns item n. GW.2003, n. GW.4000 and n. GW.6000 (old models).



GTL-3

Articolo Item	Tipo Type	Volt	A.		€
S.607	Lenticolare Lenticular	1,1	0.22	25	0,21
S.609	Lenticolare Lenticular	2,2	0.25	25	0,21

CONFEZIONE IN BLISTER | BLISTER PACKAGING

Articolo Item	Tipo Type	Volt	Amp	Modello Model	Attacco Base	N° lamp./blister		€
*59171.GD	Sferetta Small sphere	12	0,3	G 11x24	E 10	2	20	0,87
*LZ.4	Xenon	2,4	0,80	B-3½	P 13,5s	2	12	2,83
*LZ.2	Xenon	2,4	0,93	B-3½	P 13,5s	2	12	2,83
*LZ.3	Xenon	3,6	0,82	B-3½	P 13,5s	2	12	2,83
*LZ.13	Xenon	4,8	0,79	B-3½	P 13,5s	2	12	2,83
*25166.GD	Alogena Halogen	4	0,85	B-3½	P 13,5s	1	20	5,79



Lampadine di ricambio per luci notte
(blister da 3 lampadine)

• E12 adatta per luci notte

Replacement lamp for night light
(3-lamps blister)

• E12 Ideal for night light

Articolo Item	Attacco Base	Volt	Watt		€
* HL.310	E 14	220	7	20	2,57
* HL.312	E 12	220	5	20	2,46



SILURO LED | LED FESTOON

- Corpo in vetro
- Led SMD con lente ad alta diffusione luminosa
- Ideale per la segnalazione
- Alimentazione: AC/DC
- Vita media: 10.000 ore
- Glass body
- SMD LED with high light diffusion lens
- Ideal for signalling
- Power supply: AC/DC
- Average life: 10,000 hours

Articolo Item	Dimensioni Dimensions Ø x L	Volt	mA	Temperatura di colore Colour temperature	Lumen	N° LED		€
AWL31.12	10 x 31 mm	12	45	6.000°K	17	4	10	4,65
AWL31.24	10 x 31 mm	24	15	6.000°K	12	4	10	4,65
AWL39.12	10 x 39 mm	12	60	6.000°K	28	6	10	5,53
AWL39.24	10 x 39 mm	24	20	6.000°K	23	6	10	5,53



SILURO FILAMENTO | FILAMENT FESTOON

Lampade siluro per segnalazione

Signalling festoon bulbs

- Corpo in vetro o in policarbonato (mod. S.104)
- Virola nichelata
- Body in glass or in polycarbonate (mod. S.104)
- Nickel plated ferrule

SV 6-6 siluro in vetro 6 x 31 mm | SV 6-6 festoon in glass 6 x 31 mm

Articolo Item	Volt	mA	Watt	Filamento Filament		€
AW.15.12	12	250	3	C-6	100	0,38
AW.15.24	24	125	3	C-6	100	0,40

SV 6-6 siluro in vetro 6 x 38 mm | SV 6-6 festoon in glass 6 x 38 mm

Articolo Item	Volt	mA	Watt	Filamento Filament		€
AW.18.12	12	250	3	C-6	100	0,38
AW.18.24	24	125	3	C-6	100	0,40

SV 7-8 siluro in vetro 8 x 36 mm | SV 7-8 festoon in glass 8 x 36 mm

Articolo Item	Volt	mA	Watt	Filamento Filament		€
AW.16.12	12	250	3	C-6	100	0,38
AW.16.24	24	125	3	C-6	100	0,40

SILURO in resina policarbonata 6 x 27 mm | FESTOON in polycarbonate resin 6 x 27 mm

Articolo Item	Volt	mA	Watt	Filamento Filament		€
S.104.110	CE 110	1 ± 0,2	3	neon	100	1,00
S.104.220	CE 220	1 ± 0,2	3	neon	100	0,43
S.104.R.110	CE 110	1 ± 0,2	3	neon rosso red neon	100	1,00
S.104.R.380	CE 380	1 ± 0,2	3	neon rosso red neon	100	1,00



TUBI FLUORESCENTI | FLUORESCENT TUBES

- Corpo in vetro
- Glass body



Articolo Item	Dimensioni Dimensions Ø x L	Attacco Base	Watt	Temp. colore Colour temp.		€
TF.6	16x212 mm	G5	6	6.400°K	10	1,60
TF.8	16x288 mm	G5	8	6.400°K	10	1,76

Lampade per segnalazione al neon

Neon signalling lamps



- Ampolla in resina policarbonata
- Virola nichelata

- Bulb in polycarbonate resin
- Nickel plated ferrule

T 10 x 28 E 10

Articolo Item		Volt	mA	Luce Light		€
S.112.110	CE	110	1,2	chiara clear	100	0,79
S.112.220	CE	220	1,2	chiara clear	100	0,57
S.112.250.V	CE	250	1,2	verde green	100	0,57



- Ampolla in resina policarbonata
- Virola nichelata

- Bulb in polycarbonate resin
- Nickel plated ferrule

T 10 x 28 Ba9s

Articolo Item		Volt	mA			€
S.111.220	CE	220	1,2		100	0,57



- Ampolla in resina policarbonata
- Virola nichelata

- Bulb in polycarbonate resin
- Nickel plated ferrule

T 16 x 54 E 14

Articolo Item		Volt	mA			€
S.116.110	CE	110	1,2		50	1,01
S.116.220	CE	220	1,2		50	1,01



- Ampolla in vetro con lente di diffusione
- Virola nichelata

- Bulb in glass with diffusion lens
- Nickel plated ferrule

T 10 x 28 E 10

Articolo Item		Volt	mA		€
S.122.220	CE	220-240	1,5	100	2,04

T 10 x 28 Ba9s

Articolo Item		Volt	mA		€
S.121.220	CE	220-240	1,5	100	1,93

Segnalatori luminosi Ø 10 mm

Light signalers Ø 10 mm

LYVIA

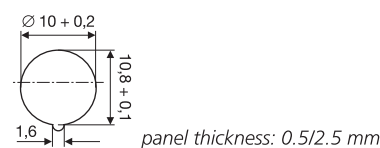
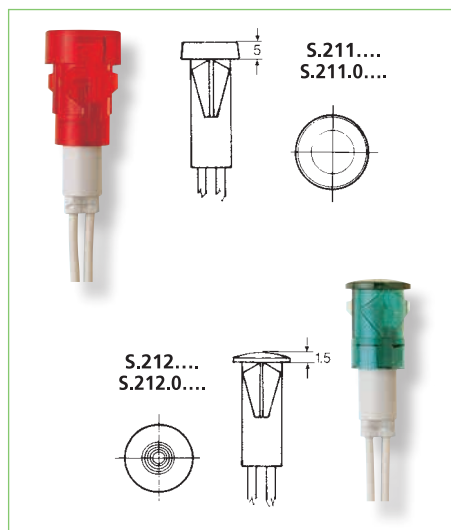

spessore del pannello: 0,5/2,5 mm
corpo autobloccante in policarbonato
con cavetti PVC
 0,50 mm² - lunghezza 200 mm
con attacco Faston
 6,3 x 0,8 mm

panel thickness: 0.5/2.5 mm
self-locking body in polycarbonate
with PVC cables
 0.50 mm² - length 200 mm
with Faston connection
 6,3 x 0,8 mm



Articolo Item	Attacco Socket	Descrizione Description		€
S.211....	cavetti cables	neon neon 110-220 V	50	1,18
S.211.VF....	cavetti cables	verde fluoro day-glo green 110-220 V	50	1,72
S.211....	cavetti cables	incandescente incandescent 6-12-24 V	50	1,18
S.211.0....	faston	neon neon 110-220 V	50	1,18
S.211.0.VF....	faston	verde fluoro day-glo green 110-220 V	50	1,72
S.211.0....	faston	incandescente incandescent 6-12-24 V	50	1,18
S.212....	cavetti cables	neon neon 110-220 V	50	1,18
S.212.VF....	cavetti cables	verde fluoro day-glo green 110-220 V	50	1,72
S.212....	cavetti cables	incandescente incandescent 6-12-24 V	50	1,18
S.212.0....	faston	neon neon 110-220 V	50	1,18
S.212.0.VF....	faston	verde fluoro day-glo green 110-220 V	50	1,72
S.212.0....	faston	incandescente incandescent 6-12-24 V	50	1,18

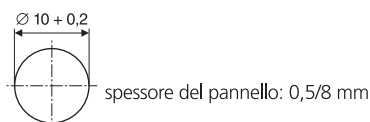
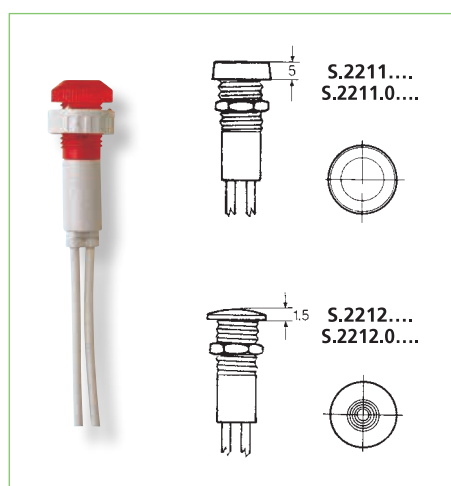

spessore del pannello: 0,5/8 mm
corpo filettato in policarbonato, completo di
rondella zigrinata a vite
con cavetti PVC
 0,50 mm² - lunghezza 200 mm
con attacco Faston
 6,3 x 0,8 mm

panel thickness: 0,5/8 mm
threaded body in polycarbonate, complete
with screw knurled washer
with PVC cables
 0,50 mm² - lunghezza 200 mm
with Faston connection
 6,3 x 0,8 mm



Articolo Item	Attacco Socket	Descrizione Description		€
S.221....	cavetti cables	neon neon 110-220 V	50	1,25
S.221.VF....	cavetti cables	verde fluoro day-glo green 110-220 V	50	1,82
S.221....	cavetti cables	incandescente incandescent 6-12-24 V	50	1,25
S.221.0....	faston	neon neon 110-220 V	50	1,25
S.221.0.VF....	faston	verde fluoro day-glo green 110-220 V	50	1,82
S.221.0....	faston	incandescente incandescent 6-12-24 V	50	1,25
S.222....	cavetti cables	neon neon 110-220 V	50	1,25
S.222.VF....	cavetti cables	verde fluoro day-glo green 110-220 V	50	1,82
S.222....	cavetti cables	incandescente incandescent 6-12-24 V	50	1,25
S.222.0....	faston	neon neon 110-220 V	50	1,25
S.222.0.VF....	faston	verde fluoro day-glo green 110-220 V	50	1,82
S.222.0....	faston	incandescente incandescent 6-12-24 V	50	1,25

Segnalatori luminosi Ø 10 mm

Light signalers Ø 10 mm

LYVIA

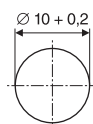
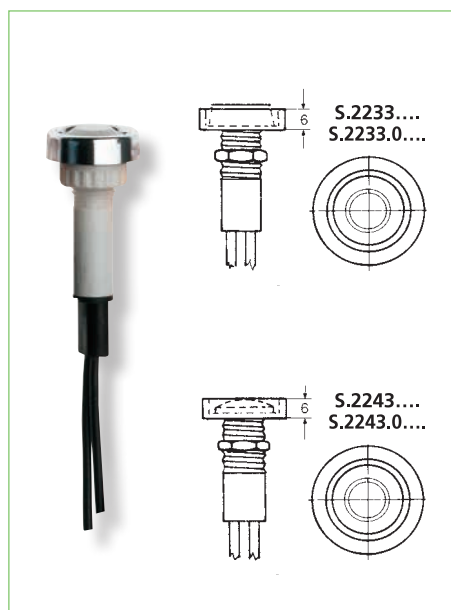

spessore del pannello: 0,5/8 mm

corpo filettato in policarbonato, completo di
rondella zigrinata a vite

con riflettore cromato

con cavetti PVC
0,50 mm² - lunghezza 200 mm

con attacco Faston
6,3 x 0,8 mm



panel thickness: 0,5/8 mm

threaded body in polycarbonate, complete
with screw knurled washer

with chrome-plated reflector

with PVC cables
0,50 mm² - lunghezza 200 mm

with Faston connection
6,3 x 0,8 mm

Articolo Item	Attacco Socket	Descrizione Description		€
S.2233....	cavetti cables	neon neon 110-220 V	50	1,69
S.2233.VF....	cavetti cables	verde fluoro day-glo green 110-220 V	50	2,29
S.2233....	cavetti cables	incandescente incandescent 6-12-24 V	50	1,69
S.2233.0....	faston	neon neon 110-220 V	50	1,69
S.2233.0.VF....	faston	verde fluoro day-glo green 110-220 V	50	2,29
S.2233.0....	faston	incandescente incandescent 6-12-24 V	50	1,69
S.2243....	cavetti cables	neon neon 110-220 V	50	1,69
S.2243.VF....	cavetti cables	verde fluoro day-glo green 110-220 V	50	2,29
S.2243....	cavetti cables	incandescente incandescent 6-12-24 V	50	1,69
S.2243.0....	faston	neon neon 110-220 V	50	1,69
S.2243.0.VF....	faston	verde fluoro day-glo green 110-220 V	50	2,29
S.2243.0....	faston	incandescente incandescent 6-12-24 V	50	1,69

Segnalatori luminosi

Light signalers

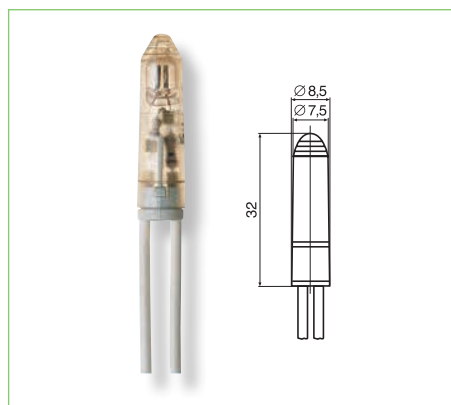

unità di segnalazione
 corpo in policarbonato
 lente conica \varnothing 7,5 - 8,5 mm
 con cavetti PVC
 0,50 mm² x 200 mm

*signalling units
 body in polycarbonate
 conical lens \varnothing 7,5 - 8,5 mm
 with PVC cables
 0,50 mm² x 200 mm*



Articolo Item		Volt	mA	Watt		€
S.102.220	CC	220	1 ± 0,2	neon	50	0,93

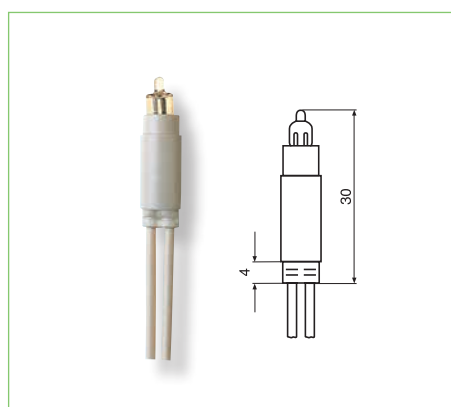

corpo in policarbonato
 con cavetti PVC
 0,50 mm² x 200 mm

*body in polycarbonate
 with PVC cables
 0,50 mm² x 200 mm*



Articolo Item		Volt	mA	Watt		€
TB.010.220	CC	220	1 ± 0,2	neon	100	0,87
TB.010.12		12	100	1,2	100	0,97
TB.010.24		24	50	1,2	100	0,97

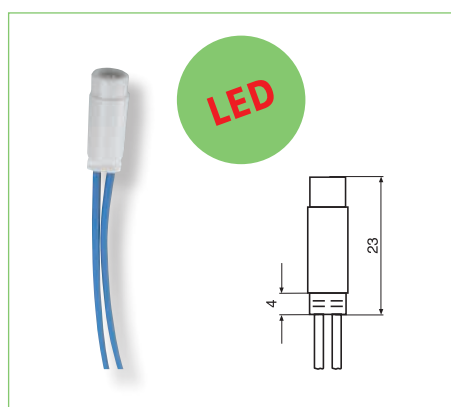

corpo in policarbonato
 Led bipolare, bassi consumi, lunga durata
 con cavetti PVC
 0,50 mm² x 150 mm

*body in polycarbonate
 Two-pole LED, low consumption, long
 duration with PVC cables
 0,50 mm² x 150 mm*



Articolo Item		Volt	mA	Watt	Colore Colour		€
TBL.010.220.W	CC	250	2,5	0,60	bianco freddo cold white	50	1,84
TBL.010.220.B	CC	250	2,5	0,60	blu blue	50	1,71
TBL.010.220.V	CC	250	2,5	0,60	verde green	50	1,71
TBL.010.220.A	CC	250	2,5	0,60	ambra amber	50	1,59
TBL.010.220.R	CC	250	2,5	0,60	rosso red	50	1,47

Segnalatori luminosi

Light signalers

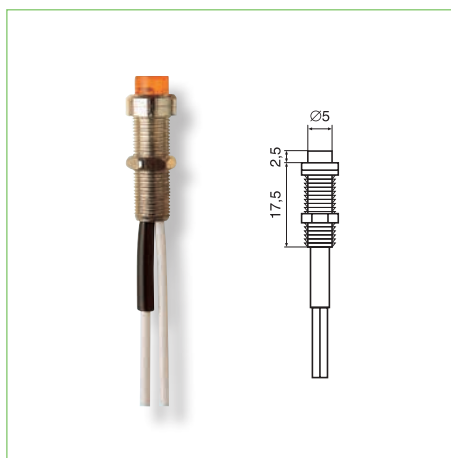

cilindrici Ø 6 mm

corpo in metallo L = 17,5 mm
lente in policarbonato Ø 0,5 mm
con cavetti PVC
 0,25 mm² x 200 mm

Disponibile nei colori:
Rosso - Verde - Trasparente



cylindrical Ø 6 mm

body in metal L = 17.5 mm
lens in polycarbonate Ø 0,5 mm
with PVC cables
 0,25 mm² x 200 mm

Available in colours:
Red - Green - Transparent

Articolo Item		Volt	mA	Watt		€
S.171.220....	€€	220	1 ± 0,2	0,22 (neon)	50	2,38
S.171.12....		12	100	1,2	50	3,30
S.171.24....		24	50	1,2	50	3,30

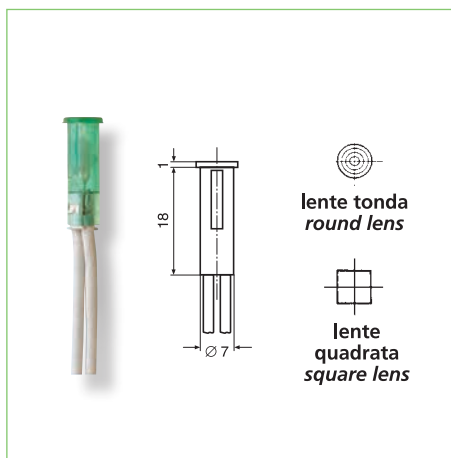

autobloccanti Ø 6 mm

corpo in policarbonato
con cavetti silicone
 0,50 mm² x 200 mm

Disponibile nei colori:
Rosso - Verde



self-locking Ø 6 mm

body in polycarbonate
with silicon cables
 0,50 mm² x 200 mm

Available in colours:
Red - Green

Articolo Item		Volt	mA	Watt		€	
S.163.220....	lente tonda round lens Ø 7 mm	€€	220	1 ± 0,2	neon	50	1,70
S.164.220....	lente quadrata square lens 7 mm	€€	220	1 ± 0,2	neon	50	1,70



E14 SFERA | E14 SPHERE

CE

Angolo di diffusione: 360°
 Dimensioni: 45 x 81 mm
 Vita media: 10.000 ore
 Con guaina protettiva interna al silicone

*Beam angle: 360°
 Dimensions: 45 x 81 mm
 Average life: 10,000 hours
 With internal silicone protective sheath*



Articolo Item	Attacco Base	Volt	Watt	Luminosità Brightness	Temperatura colore Colour temperature	Equivalente incandescenza Equivalent incandescence		€
EMB.7	E 14	230 V~ 50 Hz	7	280 lm	2700°K	35 W	25	4,20



E27 GLOBO 20 W | E27 GLOBE 20 W

CE

Angolo di diffusione: 360°
 Dimensioni: Ø 95 mm x 137 mm
 Vita media: 10.000 ore

*Beam angle: 360°
 Dimensions: Ø 95 mm x 137 mm
 Average life: 10,000 hours*



Articolo Item	Attacco Base	Volt	Watt	Luminosità Brightness	Temperatura colore Colour temperature	Equivalente incandescenza Equivalent incandescence		€
ESL.5720	E 27	230 V~ 50 Hz	20	1000 lm	2700°K	100 W	10	5,41



E27 GLOBO 25 W | E27 GLOBE 25 W

CE

Angolo di diffusione: 360°
 Dimensioni: Ø 110 mm x 150 mm
 Vita media: 10.000 ore

*Beam angle: 360°
 Dimensions: Ø 110 mm x 150 mm
 Average life: 10,000 hours*



Articolo Item	Attacco Base	Volt	Watt	Luminosità Brightness	Temperatura colore Colour temperature	Equivalente incandescenza Equivalent incandescence		€
ESL.5725	E 27	230 V~ 50 Hz	25	1350 lm	2700°K	125 W	10	5,79



E14 SPIRALE | E14 SPIRAL

CE

Angolo di diffusione: 360°
 Dimensioni: 31 x 90 mm
 Vita media: 10.000 ore
 Tubo T2

*Beam angle: 360°
 Dimensions: 31 x 90 mm
 Average life: 10,000 hours
 T2 Tube*



Articolo Item	Attacco Base	Volt	Watt	Luminosità Brightness	Temperatura colore Colour temperature	Equivalente incandescenza Equivalent incandescence		€
ESF.7	E 14	230 V~ 50 Hz	7	280 lm	2700°K	35 W	25	3,31



E27 SPIRALE | E27 SPIRAL

CE

Angolo di diffusione: 360°
 Dimensioni: 38 x 108 mm
 Vita media: 10.000 ore
 Tubo T2

*Beam angle: 360°
 Dimensions: 38 x 108 mm
 Average life: 10,000 hours
 T2 Tube*



Articolo Item	Attacco Base	Volt	Watt	Luminosità Brightness	Temperatura colore Colour temperature	Equivalente incandescenza Equivalent incandescence		€
ESF.11	E 27	230 V~ 50 Hz	11	540 lm	2700°K	70 W	25	3,74



E27 TUBOLARE | E27 TUBULAR

CE

Angolo di diffusione: 360°
 Dimensioni: 38 x 105 mm
 Vita media: 10.000 ore
 Tubo T2

*Beam angle: 360°
 Dimensions: 38 x 105 mm
 Average life: 10,000 hours
 T2 Tube*



Articolo Item	Attacco Base	Volt	Watt	Luminosità Brightness	Temperatura colore Colour temperature	Equivalente incandescenza Equivalent incandescence		€
ESF.9	E 27	230 V~ 50 Hz	9	420 lm	2700°K	45 W	25	3,45



DICROICHE | DICHROIC

Diametro: 50 mm
 Vita media: 2.000 ore
 Blocco totale dei raggi UV

Diameter: 50 mm
 Average life: 2,000 hours
 Total UV ray block

con vetro di protezione

with protection glass



Articolo Item	Attacco Base	Volt	Watt	Luminosità Brightness	Temperatura colore Colour temperature	Equivalente incandescenza Equivalent incandescence	Fascio ANSI ANSI beam		€
681.942	MR-16	12	35	730 lm	3000°K	-	36° FMW	25	0,90



BISPINA | BI-PIN

Spina: Ø 0,75 mm
 Dimensioni: 9 x 30 mm
 Vita media: 2.000 ore
 Blocco totale dei raggi UV

Plug: Ø 0,75 mm
 Dimensions: 9 x 30 mm
 Average life: 2,000 hours
 Total UV ray block



Articolo Item	Attacco Base	Volt	Watt	Luminosità Brightness	Temperatura colore Colour temperature	Equivalente incandescenza Equivalent incandescence		€
660.958	G4	24	35	650 lm	3000°K	-	100	0,53



BISPINA | BI-PIN

Ecoalogen

Dimensioni: 13 x 44 mm
 Vita media: 1.500 ore
 Blocco totale dei raggi UV

Dimensions: 13 x 44 mm
 Average life: 1,500 hours
 Total UV ray block



Articolo Item	Attacco Base	Volt	Watt	Luminosità Brightness	Temperatura colore Colour temperature	Equivalente incandescenza Equivalent incandescence		€
666.001	G9	230	18	204 lm	3000°K	25 W	100	1,46
666.002	G9	230	28	370 lm	3000°K	40 W	100	1,46
666.003	G9	230	42	630 lm	3000°K	60 W	100	1,46

Lampade ad alogeni standard

Standard halogen lamps

LYVIA



LINEARI | LINEAR

Ecoalogena

CE



Filamento rinforzato CC-8
 Vita media: 2.000 ore
 Blocco totale dei raggi UV
 Angolo di diffusione: 360°
Dimmerabili

Reinforced CC-8 filament
 Average life: 2,000 hours
 Total UV ray block
 Beam angle: 360°
Dimmable

Dimensioni | Dimensions: 8 x 78 mm

Articolo Item	Attacco Base	Volt	Watt	Luminosità Brightness	Temperatura colore Colour temperature	Equivalente alogena Equivalent halogen		€
692.177.C	R7s	230	70	1.200 lm	2700°K	100 W	50	2,07
692.179.C	R7s	230	105	1.900 lm	2700°K	150 W	50	2,07
692.181.C	R7s	230	140	2.650 lm	2700°K	200 W	50	2,07
692.183.C	R7s	230	175	3.450 lm	2700°K	250 W	50	2,07

Dimensioni | Dimensions: 8 x 117 mm

Articolo Item	Attacco Base	Volt	Watt	Luminosità Brightness	Temperatura colore Colour temperature	Equivalente alogena Equivalent halogen		€
691.178.C	R7s	230	70	1.200 lm	2700°K	100 W	50	2,07
691.180.C	R7s	230	120	1.900 lm	2700°K	150 W	50	2,07
691.182.C	R7s	230	140	2.650 lm	2700°K	200 W	50	2,07
691.185.C	R7s	230	200	4.000 lm	2700°K	300 W	50	2,07

Dimensioni | Dimensions: 10 x 118 mm

Articolo Item	Attacco Base	Volt	Watt	Luminosità Brightness	Temperatura colore Colour temperature	Equivalente alogena Equivalent halogen		€
691.186.C	R7s	230	350	7.400 lm	2700°K	500 W	50	2,07



TUBOLARI | TUBULAR

Ecoalogena

CE



Vita media: 2.000 ore
 Vetro chiaro
 Blocco totale dei raggi UV
 Angolo di diffusione: 360°
Dimmerabili

Average life: 2,000 hours
 Clear glass
 Total UV ray block
 Beam angle: 360°
Dimmable

Articolo Item	Attacco Base	∅	H	Volt	Watt	Luminosità Brightness	Temperatura colore Colour temperature	Equivalente alogena Equivalent halogen		€
711.950.C	E 14	19 mm	66 mm	230	52	840 lm	2700°K	70 W	20	2,89
711.980.C	E 14	19 mm	66 mm	230	70	1200 lm	2700°K	100 W	20	2,89
711.982.C	E 14	19 mm	76 mm	230	100	1800 lm	2700°K	130 W	20	2,89
711.984.C	E 14	19 mm	83 mm	230	130	2500 lm	2700°K	200 W	20	2,89
711.986.C	E 14	19 mm	83 mm	230	175	3500 lm	2700°K	250 W	20	2,89

Doppio involucro di sicurezza | Safety double casing

Articolo Item	Attacco Base	∅	H	Volt	Watt	Luminosità Brightness	Temperatura colore Colour temperature	Equivalente alogena Equivalent halogen		€
811.956.C	E 27	32 mm	105 mm	230	52	840 lm	2700°K	70 W	20	5,38
811.980.C	E 27	32 mm	105 mm	230	70	1200 lm	2700°K	100 W	20	5,38
811.982.C	E 27	32 mm	105 mm	230	100	1800 lm	2700°K	130 W	20	5,38
811.984.C	E 27	32 mm	105 mm	230	130	2500 lm	2700°K	200 W	20	5,38
811.985.C	E 27	32 mm	105 mm	230	175	3500 lm	2700°K	250 W	20	5,38



Lampadine con effetto oscillante che dà la sensazione della fiamma di una candela di cera.

Lamps with oscillating effect that appears like the flame of a wax candle.

COUP DE VENT

CE

- chiara
- filamento neon
- dimensioni: 30 x 110 mm

- clear
- neon filament
- dimensions: 30 x 110 mm

Articolo Item	Attacco Base	Volt	Watt	Luminosità Brightness	Colore Colour	Equivalente incandescenza Equivalent incandescence		€
3656	E 14	220	3	–	Chiara Clear	–	20	1,52



FIAMMA | FLAME

CE

- chiara
- filamento neon

- clear
- neon filament

Dimensioni | Dimensions: 14 x 75 mm

Articolo Item	Attacco Base	Volt	Watt	Luminosità Brightness	Colore Colour	Equivalente incandescenza Equivalent incandescence		€
3650	E 14	220	3	–	Chiara Clear	–	20	1,52

Dimensioni | Dimensions: 23 x 55 mm

Articolo Item	Attacco Base	Volt	Watt	Luminosità Brightness	Colore Colour	Equivalente incandescenza Equivalent incandescence		€
3651	E 14	220	3	–	Chiara Clear	–	20	1,33



OLIVA | OLIVE

CE

- chiara
- filamento neon
- dimensioni: 30 x 110 mm

- clear
- neon filament
- dimensions: 30 x 110 mm

Articolo Item	Attacco Base	Volt	Watt	Luminosità Brightness	Colore Colour	Equivalente incandescenza Equivalent incandescence		€
3659	E 14	220	3	–	Chiara Clear	–	20	1,69

Ecoalogen^a

- luce naturale 2700°K
- blocco totale dell'emissione di raggi UV
- completamente dimmerabili
- funzionamento a tensione di rete
- vita media: 2000 ore
- bulbo in vetro
- natural light 2700°K
- total UV ray emission block
- fully dimmable
- mains voltage operation
- average life: 2000 hours
- glass bulb



CANDELA (OLIVA) | CANDLE (OLIVE)

CE

- chiara
- angolo di diffusione: 360°
- dimensioni: 35 x 97 mm
- clear
- beam angle: 360°
- dimensions: 35 x 97 mm



Articolo Item	Attacco Base	Volt	Watt	Luminosità Brightness	Temperatura colore Colour temperature	Equivalente alogena Equivalent halogen		€
58118	E 14	230	18	205 lm	2700°K	25 W	25	1,22
58128	E 14	230	28	370 lm	2700°K	40 W	25	1,22



PICCOLA SFERA | SMALL SPHERE

CE

- chiara
- angolo di diffusione: 360°
- dimensioni: 45 x 75 mm (E14)
45 x 72 mm (E27)
- clear
- beam angle: 360°
- dimensions: 45 x 75 mm (E14)
45 x 72 mm (E27)



Articolo Item	Attacco Base	Volt	Watt	Luminosità Brightness	Temperatura colore Colour temperature	Equivalente alogena Equivalent halogen		€
45018	E 14	230	18	205 lm	2700°K	25 W	25	1,19
45028	E 14	230	28	370 lm	2700°K	40 W	25	1,19
45118	E 27	230	18	205 lm	2700°K	25 W	25	1,19



GOCCIA | STANDARD

CE

- chiara
- angolo di diffusione: 360°
- dimensioni: 55 x 102 mm
- clear
- beam angle: 360°
- dimensions: 55 x 102 mm



Articolo Item	Attacco Base	Volt	Watt	Luminosità Brightness	Temperatura colore Colour temperature	Equivalente alogena Equivalent halogen		€
55142	E 27	230	42	630 lm	2700°K	60 W	25	1,19



FLAME

- chiara
- diffusore in vetro
- virola nichelata
- dimensioni: 35 x 125 mm

- clear
- glass diffuser
- nickel plated ferrule
- dimensions: 35 x 125 mm



Articolo Item	Attacco Base	Volt	Watt	Filamento Filament	Colore Colour	Equivalente incandescenza Equivalent incandescence		€
59154.C	E 14	240	15	C-5A	chiara clear	–	25	1,01



SFERA LED | LED SPHERE

Lampada in polycarbonato con finitura bianca opale con 18 led bianchi ad altissima luminosità.

Lamp in polycarbonate with opal white finish with 18 very high brightness white LEDs.

Grado di protezione IP44

Protection degree IP44

- colore: bianco
- dimensioni: Ø 50x100 mm

- colour: white
- dimensions: Ø 50x100 mm

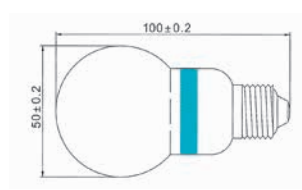
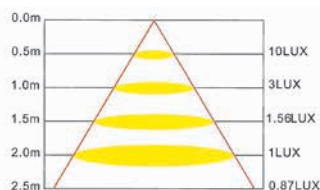

Articolo Item	Attacco Base	Volt	Watt	Luminosità Brightness	Temperatura colore Colour temperature	Equivalente incandescenza Equivalent incandescence		€
LO.1	E 27	220 AC ± 10 V	1	150 lm	5000°-7000°K (pure white)	–	10	6,16



Zanzout

Innovative lampadine LED con luce giallo/arancio, con una frequenza in grado di allontanare zanzare, falene ed altri insetti notturni.

Innovative LED bulbs with yellow/orange light, with a frequency able to send away mosquitoes, moths and other nocturnal insects.

- Bulbo in plastica termoconduttiva ed alluminio opacizzato
- Temperatura di colore: 610nm (giallo/arancio)
- Apertura fascio: 180°
- Vita media: 15.000 ore
- Dimensioni: 60 x 119 mm
- Peso: 47gr
- Temperatura di funzionamento: -20 +40° C

- Body in thermoconductive plastic and opaque aluminum
- Colour temperature: 610nm (yellow/orange)
- Beam angle: 180°
- Average life: 15,000 hours
- Dimensions: 60 x 119 mm
- Weight: 47gr
- Working temperature: -20 + 40 ° C



Articolo Item	Attacco Base	Volt	Watt	Luminosità Brightness	Colore Colour		€
Z06	E 27	220-240V/50-60Hz	6	200 lm	Giallo/arancio Yellow/orange	10	8,00



T 18 GOCSETTA per luminarie T 18 DROP for luminaires

CE

Con dispositivo di corto circuito

- corpo in vetro
- filamento
- dimensioni: 18 x 46 mm

With short circuit device

- glass body
- filament
- dimensions: 18 x 46 mm

Articolo Item	Attacco Base	Volt	Watt	Luminosità Brightness	Colore Colour	Equivalente incandescenza Equivalent incandescence		€
60220	E 14	14	5	29 lm	chiara clear	–	50	0,30
60250	E 14	14	5	–	assortite assorted	–	50	0,36
60255	E 14	14	5	9 lm	rossa red	–	50	0,36
60256	E 14	14	5	24 lm	gialla yellow	–	50	0,36
60257	E 14	14	5	8 lm	verde green	–	50	0,36
60258	E 14	14	5	7 lm	blu blue	–	50	0,36
60259	E 14	14	5	10 lm	ciclamino cyclamen	–	50	0,36



SFERA per ghirlande | SPHERE for garlands

CE

- chiara
- dimensioni: Ø 25 x 45 mm (E14)
Ø 45 x 70 mm (E27)

- clear
- dimensions: Ø 25 x 45 mm (E14)
Ø 45 x 70 mm (E27)

Articolo Item	Attacco Base	Volt	Watt	Luminosità Brightness	Colore Colour	Equivalente incandescenza Equivalent incandescence		€
1040	E 14	220	10	–	chiara clear	–	50	0,95
1070	E 27	220	10	–	chiara clear	–	25	1,10



Per lampade votive - cimiteri For votive lamps - cemeteries

CE

- corpo in vetro
- filamento
- chiara
- dimensioni: Ø 19 x 46 mm

- glass body
- filament
- clear
- dimensions: Ø 19 x 46 mm

Articolo Item	Attacco Base	Volt	Watt	Luminosità Brightness	Colore Colour	Equivalente incandescenza Equivalent incandescence		€
60260	E 14	24	1,5	4 lm	chiara clear	–	50	0,29
60265	E 14	24	3	15 lm	chiara clear	–	50	0,29
60266	E 14	45	1,5	3 lm	chiara clear	–	50	0,33



CANDELA LED | LED CANDLE

- corpo in policarbonato trasparente
- 1 Led alta luminosità, risparmio energetico
- dimensioni: Ø 16 x 44 mm

- body in transparent polycarbonate
- 1 high brightness LED, energy savings
- dimensions: Ø 16 x 44 mm

adatta come ricambio per le nuove
candele votive elettriche

suitable as replacement for the new electrical
votive candles

Articolo Item	Attacco Base	Volt	Watt	Luminosità Brightness	Colore Colour	Equivalente incandescenza Equivalent incandescence		€
1546	E 10	12	0,2	4 lm	3000°K bianco caldo 3000°K warm white	–	50	1,82



Si possono sostituire le vecchie lampadine ad incandescenza sulle tradizionali cordoniere o catene luminose con un risparmio di energia del 70%

Corpo in policarbonato adatte per cordoniere in serie
Vita superiore alle 30.000 ore
Basso consumo

- Led: 2
- dimensioni: Ø 18 x 46 mm

The old incandescence bulbs can be replaced on traditional strings or light chains with approximately 70% energy savings

Body in polycarbonate suitable for strings in series
Life exceeding 30,000 hours
Low consumption

- Led: 2
- dimensions: Ø 18 x 46 mm

Articolo Item	Attacco Base	Volt	Watt	Luminosità Brightness	Colore Colour	Equivalente incandescenza Equivalent incandescence		€
141946.W	E 14	14 AC	0,20	–	bianco puro 6000°K pure white 6000°K	–	50	1,61
141946.WW	E 14	14 AC	0,20	–	bianco caldo 3000°K warm white 3000°K	–	100	1,61
141946.B	E 14	14 AC	0,20	–	blu blue	–	50	1,61
141946.G	E 14	14 AC	0,20	–	gialla yellow	–	50	1,61
141946.R	E 14	14 AC	0,20	–	rossa red	–	50	1,61
141946.V	E 14	14 AC	0,20	–	verde green	–	50	1,61



Corpo in policarbonato adatte per cordoniere in serie

Vita superiore alle 50.000 ore
Basso consumo

- Led: 3
- dimensioni: Ø 23 x 52 mm

Body in polycarbonate suitable for strings in series

Life exceeding 50,000 hours
Low consumption

- Led: 3
- dimensions: Ø 23 x 52 mm

Articolo Item	Attacco Base	Volt	Watt	Luminosità Brightness	Colore Colour	Equivalente incandescenza Equivalent incandescence		€
142352.B	E 14	14 AC	0,20	3500 mcd	blu blue	–	20	1,46



LAMPADE VOTIVE | VOTIVE LAMPS

(adatte per i lumi votivi nei cimiteri)

Corpo in policarbonato

Vita superiore alle 50.000 ore
Basso consumo

- Led: 3
- dimensioni: Ø 23 x 52 mm

(suitable for votive lights in cemeteries)

Body in polycarbonate

Life exceeding 50,000 hours
Low consumption

- Led: 3
- dimensions: Ø 23 x 52 mm

Articolo Item	Attacco Base	Volt	Watt	Luminosità Brightness	Colore Colour	Equivalente incandescenza Equivalent incandescence		€
2352.W	E 14	24 AC/DC	0,50	9200 mcd	bianco 5500°K white 5500°K	–	50	3,13
2352.A	E 14	24 AC/DC	0,50	9200 mcd	ambra 4500°K amber 4500°K	–	50	2,25
2352.G	E 14	24 AC/DC	0,50	9200 mcd	giallo 4500°K yellow 4500°K	–	50	2,25



Plafoniere Led Britelite Plus

Led celiling lamps Britelite Plus



Queste mini plafoniere utilizzano led SMD di ultimissima generazione che a parità di assorbimento garantiscono un flusso luminoso più elevato. Inoltre si è ricercata la componentistica che pur rispondendo alle normative (i prodotti sono tutti approvati dal GS tedesco), e senza ridurre il grado di prestazione, assicurasse delle dimensioni ridotte.

Con il profilo in alluminio verniciato bianco, di sezione standard di 30x22 mm (H x P) vengono sviluppati 5 modelli differenti, da 5 W, 10 W, 13 W, 20 W, 24 W, dove le variabili sono la lunghezza, la potenza della lampada ed i flussi luminosi da 500 a 2.600 lumen. Sono disponibili tre versioni: a luce calda 3.000°K, a luce diurna 4.000°K ed a luce fredda 6.000°K.

Le basse potenze per alte rese luminose, consentono un'ottima efficienza e un elevato risparmio energetico. Grazie alle ridotte dimensioni delle "testate" è possibile innestare direttamente una plafoniera con l'altra senza l'ausilio di connettori separati; si ottengono così delle lunghe "strisce luminose", senza bisogno di alimentare singolarmente ogni plafoniera. La base è costruita in alluminio verniciato bianco. Questa scelta tecnica conferisce robustezza al prodotto e consente una notevole dissipazione termica, aumentando così efficienza e durata dei led. Ne consegue una minore necessità di manutenzione e quindi un ulteriore risparmio energetico. Lo schermo in policarbonato ha anch'esso una doppia funzione: quella di proteggere i led e quella di propagare uniformemente la diffusione della luce prodotta dai led.

These mini ceiling lamps use the latest generation of SMD LEDs that, with the same absorption, guarantee a higher luminous flux. Furthermore, were researched components that meet the regulations (the products are all approved by the German GS) and, without reducing the degree of performance, ensure small size.

With white painted aluminum profile, standard section of 30x22 mm (H x D), are developed 5 different models, from 5 W, 10 W, 13 W, 20 W, 24 W, where the variables are the length, the power of the lamp and the light flux from 500 to 2,600 lumens.

Three versions are available: warm light 3,000°K, daylight 4,000°K and cool light 6,000°K. The low consumptions and high light yields, allow excellent efficiency and a high energy savings.

Thanks to the reduced dimensions of the "heads" it is possible to directly insert one ceiling lamp with the other without the use of separate connectors; so they are long "Light strips", without need to power individually each ceiling light.

The base is made of white painted aluminum. This technical choice gives robustness to the product and allows a remarkable thermal dissipation, thus increasing efficiency and duration of the LEDs. It follows a lower need for maintenance and therefore further energy savings. The polycarbonate screen also has a double function: to protect the LEDs and to spread uniformly the diffusion of the light produced by the LEDs.

plus
Britelite
luce continua



Ancora più luminose

Even brighter



- Bassi consumi
- Alta resa luminosa
- Luce su tutta la lunghezza
- Base in alluminio verniciato bianco
- Schermo in policarbonato
- Prolungabili, ad inserzione diretta sino a 120 W
- Complete di cavo alimentazione, cavodi raccordo e clip per il fissaggio a muro
- Alimentazione: 230V - 50 Hz
- Grado di protezione: IP 20
- Resa cromatica: >80
- Temperatura di funzionamento: -20 +50°C
- Vita media: 25.000 ore

- Low consumption
- High light yield
- Light on the entire length
- Base in white painted aluminium
- Polycarbonate diffuser
- Extendable, by direct insertion, up to 120 W
- Complete with power supply cord, connecting cable and fixing clips
- Power supply voltage: 230V - 50 Hz
- Protection degree: IP 20
- Colour rendering: >80
- Working temperature: -20 +50°C
- Average life: 25.000 hours



LUCE BIANCA CALDA 3.000°K | WARM WHITE LIGHT 3,000°K

Articolo Item	Watt	Lumen	Dimensioni Dimensions	Corrispondente fluorescente Corresponding fluorescent		€
*BR05.WW	5	500	313x22x30 mm	8 W	10/30	13,85
*BR08.WW	10	1.000	543x22x30 mm	13 W	10/30	17,60
*BR13.WW	13	1.300	873x22x30 mm	21 W	10/30	20,60
*BR19.WW	20	2.000	1.173x22x30 mm	28 W	10/20	25,45
*BR21.WW	24	2.400	1.473x22x30 mm	35 W	10/20	30,00

LUCE BIANCA DIURNA 4.000°K | DAYLIGHT 4,000°K

Articolo Item	Watt	Lumen	Dimensioni Dimensions	Corrispondente fluorescente Corresponding fluorescent		€
*BR05.D	5	525	313x22x30 mm	8 W	10/30	13,85
*BR08.D	10	1.050	543x22x30 mm	13 W	10/30	17,60
*BR13.D	13	1.365	873x22x30 mm	21 W	10/30	20,60
*BR19.D	20	2.100	1.173x22x30 mm	28 W	10/20	25,45
*BR21.D	24	2.550	1.473x22x30 mm	35 W	10/20	30,00

LUCE BIANCA FREDDA 6.000°K | COOL WHITE LIGHT 6,000°K

Articolo Item	Watt	Lumen	Dimensioni Dimensions	Corrispondente fluorescente Corresponding fluorescent		€
*BR05.W	5	550	313x22x30 mm	8 W	10/30	13,85
*BR08.W	10	1.100	543x22x30 mm	13 W	10/30	17,60
*BR13.W	13	1.400	873x22x30 mm	21 W	10/30	20,60
*BR19.W	20	2.200	1.173x22x30 mm	28 W	10/20	25,45
*BR21.W	24	2.600	1.473x22x30 mm	35 W	10/20	30,00

ACCESSORI | ACCESSORIES

Articolo Item	Descrizione Description		€
BR.CC15	Cavo di raccordo Connecting cable L = 15 cm	10	1,15
BR.CLIP	Clip in metallo per fissaggio Metal clips for fixing	20	0,18

Schermo in policarbonato | Polycarbonate diffuser

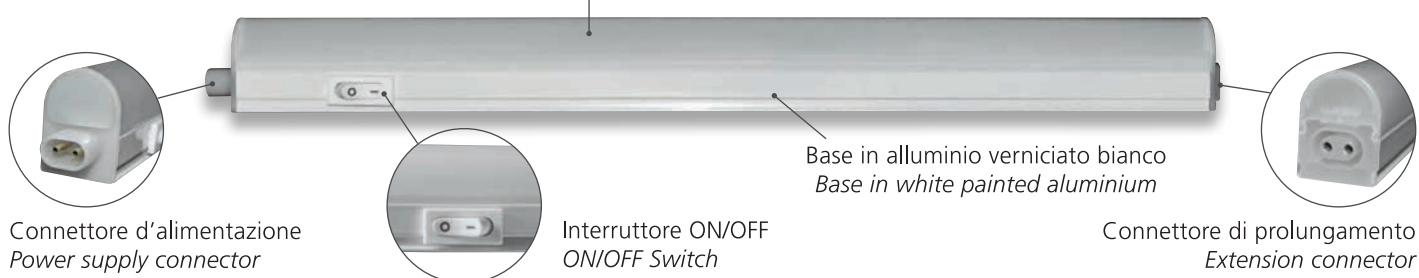

*I prodotti contraddistinti da asterisco sono in confezione blisterata già pronta per gli espositori di vendita.
*Products marked by an asterisk are in a blister package ready for shop displays.

Plafoniere fluorescenti compatte

Compact fluorescent ceiling lights

LYVIA



SUPERMINILITE
ABBINABILE

Miniplafoniere fluorescenti con tubo T5. Abbinabili le une alle altre grazie ai connettori maschio / femmina posti alle estremità. Dimensioni compatte.

Mini fluorescent ceiling lamps with T5 tube. These can be extended thanks to male / female connectors placed at the ends. Compact size.

Queste plafoniere sono pronte per l'allacciamento e sono fornite di tubo T5 al trifosforo, di cavo di alimentazione da 170 cm circa, interruttore, cavo di raccordo, viti di fissaggio, clip per il fissaggio a scatto.

These ceiling lights are ready for connection and are fitted with triphosphorous T5 tube, power supply cord 170 cm approx., switch, connecting cable, fixing screws, clip for snap-on fastening.



Caratteristiche tecniche:

- Tensione di alimentazione: 230 V~
- Frequenza di rete: 50 Hz
- Corpo in policarbonato
- Diffusore polimetacrilato trasparente rigato
- Riflettore bianco (alta resa luminosa)
- Interruttore ON/OFF sulla base
- Abbinabili sino a max 200 W ca.
- Classe di isolamento: \square
- Temperatura di funzionamento: da +5°C a +45°C
- Grado di protezione: IP 20

Technical features:

- Power supply voltage: 230 V~
- Mains frequency: 50 Hz
- Body in polycarbonate
- Transparent striped polymethacrylate diffuser
- White reflector (high light yield)
- ON/OFF switch on the base
- Extendable up to max 200 W approx.
- Insulation class: \square
- Working temperature: from +5°C to +45°C
- Protection degree: IP 20

TRIFOSFORO GRADO A + AMALGAM



Plafoniere fluorescenti compatte

Compact fluorescent ceiling lights

LYVIA



LUCE BIANCA CALDA | WARM WHITE LIGHT

Uso: abitazione, sotto pensili, banchi per negozi | Use: residential, under shelves, shop counters

Articolo Item	Watt	Dimensioni Dimensions	Temperatura di colore Colour temperature	Finitura Finish		€
*LNK.6.WW	6	280 X 22 X 42 mm	2700°K	Bianca White	30/60	13,80
*LNK.8.WW	8	350 X 22 X 42 mm	2700°K	Bianca White	30/60	14,15
*LNK.13.WW	13	570 X 22 X 42 mm	2700°K	Bianca White	30/60	16,50
*LNK.21.WW	21	915 X 22 X 42 mm	2700°K	Bianca White	20/40	21,60
*LNK.28.WW	28	1215 X 22 X 42 mm	2700°K	Bianca White	20/40	24,75

LUCE BIANCA DIURNA | DAYLIGHT

Uso: scuole, uffici, grandi magazzini | Use: schools, offices, department stores

Articolo Item	Watt	Dimensioni Dimensions	Temperatura di colore Colour temperature	Finitura Finish		€
*LNK.4100.6	6	280 X 22 X 42 mm	4100°K	Bianca White	30/60	13,80
*LNK.4100.8	8	350 X 22 X 42 mm	4100°K	Bianca White	30/60	14,15
*LNK.4100.13	13	570 X 22 X 42 mm	4100°K	Bianca White	30/60	16,50
*LNK.4100.21	21	915 X 22 X 42 mm	4100°K	Bianca White	20/40	21,60
*LNK.4100.28	28	1215 X 22 X 42 mm	4100°K	Bianca White	20/40	24,75

LUCE BIANCA FREDDA | COOL WHITE LIGHT

Uso: vetrine negozi | Use: shop windows

Articolo Item	Watt	Dimensioni Dimensions	Temperatura di colore Colour temperature	Finitura Finish		€
*LNK.6	6	280 X 22 X 42 mm	6400°K	Bianca White	30/60	13,80
*LNK.8	8	350 X 22 X 42 mm	6400°K	Bianca White	30/60	14,15
*LNK.13	13	570 X 22 X 42 mm	6400°K	Bianca White	30/60	16,50
*LNK.21	21	915 X 22 X 42 mm	6400°K	Bianca White	20/40	21,60
*LNK.28	28	1215 X 22 X 42 mm	6400°K	Bianca White	20/40	24,75

ANODIZZATE | ANODISED

Uso: abitazione, sotto pensili, banchi per negozi | Use: residential, under shelves, shop counters

Base in alluminio anodizzato per una maggiore robustezza.

Base in anodised aluminium for greater sturdiness.

Medesime caratteristiche della versione con base in policarbonato.

Same features as the version with base in polycarbonate.

Articolo Item	Watt	Dimensioni Dimensions	Temperatura di colore Colour temperature	Finitura Finish		€
*LNK.AL.13.WW	13	570 X 24 X 42 mm	2700°K	Anodizzata Anodised	30	21,45
*LNK.AL.21.WW	21	915 X 24 X 42 mm	2700°K	Anodizzata Anodised	20	28,35
*LNK.AL.28.WW	28	1215 X 24 X 42 mm	2700°K	Anodizzata Anodised	20	34,35
*LNK.AL.35.WW	35	1515 X 24 X 42 mm	2700°K	Anodizzata Anodised	10	42,50

N.B. Per i tubi T5 fluorescenti si veda pag. 43

Per ulteriori modelli consultare catalogo LIGHTING

Note For T5 fluorescent tubes see page 43

For additional models refer to LIGHTING catalogue

*I prodotti contraddistinti da asterisco sono in confezione blisterata già pronta per gli espositori di vendita.
*Products marked by an asterisk are in a blister package ready for shop displays.

TUTTA LUCE
PRERISCALDO



Plafoniere fluorescenti (T5) con funzione di preriscaldamento, abbinabili con effetto luce continua. Grazie allo speciale ballasto elettronico con la funzione di preriscaldamento dei catodi dei tubi fluorescenti, queste plafoniere sono particolarmente indicate per usi gravosi con frequenti accensioni/spengimenti. Gli accessori per queste plafoniere sono i medesimi utilizzati per SUPERMINILITE.

Fluorescent ceiling lamps (T5) with pre-heating function, extendable with continuous light line effect. Thanks to the special electronic ballast with pre-heating function of fluorescent tube cathodes, these ceiling lamps are especially suited for heavy-duty use with frequent switching on/off. The accessories for these ceiling lamps are the same used for SUPERMINILITE.



Caratteristiche tecniche:

- Tensione di alimentazione: 230 V~
- Frequenza di rete: 50 Hz
- Corpo in policarbonato
- Diffusore polimetacrilato trasparente rigato
- Riflettore bianco (alta resa luminosa)
- Interruttore ON/OFF sulla base
- Ingombri ridotti: -27 mm
- Abbinabili sino a max 200 W ca.
- Classe di isolamento:
- Temperatura di funzionamento: da +5°C a +45°C
- Grado di protezione: IP 20
- Complete di accessori quali: cavo d'alimentazione L=170 cm, cavo di raccordo, clip per fissaggio.

Technical features:

- Power supply voltage: 230 V~
- Mains frequency: 50 Hz
- Body in polycarbonate
- Transparent striped polymethacrylate diffuser
- White reflector (high light yield)
- ON/OFF switch on the base
- Compact size: -27 mm
- Extendable up to max 200 W approx.
- Insulation class:
- Working temperature: from +5°C to +45°C
- Protection degree: IP 20
- Complete with accessories: power supply cord L=170 cm, connecting cable, fixing clip.

Queste plafoniere vanno equipaggiate con tubi fluorescenti T5 (si veda pag 43).

These ceiling lamps must be equipped with fluorescent T5 tubes (see page 43).

N.B. La funzione di preriscaldamento necessita di un tempo d'attesa tra il comando e l'accensione del tubo, che generalmente è tra i 2 e i 4 sec., specialmente alla prima accensione dopo un periodo d'inattività.

Note: The pre-heating function requires a waiting time between command and tube ignition which is generally between 2 and 4 sec., especially on first switching on after an inactivity period.

SOLO BASE - SENZA TUBO | BASE ONLY - WITHOUT TUBE

Articolo Item	Watt	Dimensioni Dimensions	Finitura Finish		€
*PTL.8	8	323 X 22 X 42 mm	bianca white	30	12,90
*PTL.13	13	552 X 22 X 42 mm	bianca white	30	14,80
*PTL.21	21	884 X 22 X 42 mm	bianca white	20	18,70

N.B. Per i tubi T5 fluorescenti si veda pag. 43
Per ulteriori modelli consultare catalogo LIGHTING

Note For T5 fluorescent tubes see page 43
For additional models refer to LIGHTING catalogue

Tubi fluorescenti (T5)

Fluorescent tubes (T5)

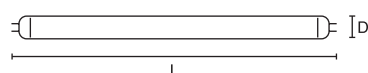

Alta efficienza luminosa con risparmio di energia del 20% in confronto dei T8 di pari potenza.

High light efficiency with 20% energy savings compared to equally powerful T8.

Il **TRIFOSFORO** di grado A è composto da "fosfori" dei migliori produttori mondiali e permette di raggiungere i migliori standard, tra cui la massima luminosità.

Grade A **TRIPHOSPHOROUS** consists of "phosphorus" of the best world manufacturers and makes it possible to achieve the best standards, including top brightness.

Questa tecnologia garantisce inoltre elevati livelli di luminosità ed i lumen iniziali si mantengono costanti fino all'80% del ciclo di vita della lampada.

This technology also assures high brightness levels and the initial lumens remain constant until 80% of the lamp's life cycle.

TRIFOSFORO GRADO A + AMALGAM



LUCE BIANCA EXTRA CALDA | EXTRA WARM WHITE LIGHT

Articolo Item	Watt	D mm	L mm	Attacco Base	Temperatura di colore Colour temperature	Lumen	Equivalente incand. Equivalent incand.		€
FLF.6.WW	6	16	226,3	G5	2700°K	260	30W	10/100	2,61
FLF.8.WW	8	16	302,5	G5	2700°K	380	40W	10/100	2,61
FLF.13.WW	13	16	531,1	G5	2700°K	800	65W	10/100	3,54
FLF.21.WW	21	16	863,2	G5	2700°K	1850	100W	10/100	4,51
FLF.28.WW	28	16	1163,2	G5	2700°K	2470	140W	10/100	5,48
FLF.35.WW	35	16	1463,2	G5	2700°K	3135	170W	10/100	9,28

LUCE BIANCA CALDA | WARM WHITE LIGHT

Articolo Item	Watt	D mm	L mm	Attacco Base	Temperatura di colore Colour temperature	Lumen	Equivalente incand. Equivalent incand.		€
FLF.3000.6	6	16	226,3	G5	3000°K	270	30W	10/100	2,61
FLF.3000.21	21	16	863,2	G5	3000°K	1850	100W	10/100	4,51
FLF.3000.28	28	16	1163,2	G5	3000°K	2470	140W	10/100	5,48

LUCE BIANCA DIURNA | DAYLIGHT

Articolo Item	Watt	D mm	L mm	Attacco Base	Temperatura di colore Colour temperature	Lumen	Equivalente incand. Equivalent incand.		€
FLF.4100.6	6	16	226,3	G5	4100°K	300	30W	10/100	2,61
FLF.4100.8	8	16	302,5	G5	4100°K	420	40W	10/100	2,61
FLF.4100.13	13	16	531,1	G5	4100°K	950	65W	10/100	3,54
FLF.4100.21	21	16	863,2	G5	4100°K	1850	100W	10/100	4,51
FLF.4100.28	28	16	1163,2	G5	4100°K	2470	140W	10/100	5,48
FLF.4100.35	35	16	1463,2	G5	4100°K	3135	170W	10/100	9,28

LUCE BIANCA FREDDA | COOL WHITE LIGHT

Articolo Item	Watt	D mm	L mm	Attacco Base	Temperatura di colore Colour temperature	Lumen	Equivalente incand. Equivalent incand.		€
FLF.6	6	16	226,3	G5	6400°K	210	30W	10/100	2,61
FLF.8	8	16	302,5	G5	6400°K	310	40W	10/100	2,61
FLF.13	13	16	531,1	G5	6400°K	650	65W	10/100	3,54
FLF.21	21	16	863,2	G5	6400°K	1660	100W	10/100	4,51
FLF.28	28	16	1163,2	G5	6400°K	2350	140W	10/100	5,48
FLF.35	35	16	1463,2	G5	6400°K	2890	170W	10/100	9,28



BASI | BASES

Base della plafoniera fluorescente tipo LNK completa di:

- Cavo di alimentazione H03 VV H2-F 2x 0,75 mm² con spina, lunghezza 170 cm circa
- Cavo di raccordo 15 cm circa
- Staffe, clip e viti di fissaggio
- Schermo in materiale acrilico
- Queste basi vanno equipaggiate con tubi fluorescenti T5 (si veda a pag. 43)

Base of the fluorescent ceiling lamp type LNK complete with:

- Power supply cord H03 VV H2-F 2x 0.75 mm² with plug, length 170 cm approx.
- Connecting cable 15 cm approx.
- Fixing brackets, clips and screws
- Diffuser in acrylic material
- These bases must be equipped with fluorescent T5 tubes (see page 43)

SOLO BASE - SENZA TUBO | BASE ONLY - WITHOUT TUBE

Articolo Item	Watt	Dimensioni Dimensions	Finitura Finish		€
Corpo in policarbonato Body in polycarbonate					
BASE.6	6	280 x 22 x 42 mm	Bianca White	30	12,40
BASE.21	21	915 x 22 x 42 mm	Bianca White	20	19,65
BASE.35	35	1515 x 22 x 42 mm	Bianca White	10	32,10
Corpo in alluminio anodizzato Anodised aluminium body					
BASE.AL.35	35	1515 x 24 x 42 mm	Anodizzata Anodised	10	33,05
Corpo in alluminio verniciato bianco Body in white painted aluminium					
BASE.AB.35	35	1515 x 24 x 42 mm	Bianca White	10	32,20



SCHERMI | SCREENS

Schermi per LNK, TTL e PTL

In polimetacrilato rigato

Screens for LNK, TTL and PTL

In striped polymethacrylate

Articolo Item	Descrizione Description		€
DK6	ricambio per plafoniere da 6 W fluorescenti replacement for 6 W fluorescent ceiling lamps	10	1,21
DK8	ricambio per plafoniere da 8 W fluorescenti replacement for 8 W fluorescent ceiling lamps	10	1,40
DK13	ricambio per plafoniere da 13 W fluorescenti replacement for 13 W fluorescent ceiling lamps	10	2,42
DK21	ricambio per plafoniere da 21 W fluorescenti replacement for 21 W fluorescent ceiling lamps	10	3,59
DK28	ricambio per plafoniere da 28 W fluorescenti replacement for 28 W fluorescent ceiling lamps	10	4,71
DK35	ricambio per plafoniere da 35 W fluorescenti replacement for 35 W fluorescent ceiling lamps	10	6,01

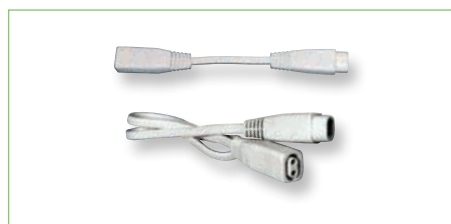

Cavi di raccordo H03 VV H2-F 2 x 0,75 mm² per abbinare le plafoniere.

Connecting cables H03 VV H2-F 2 x 0.75 mm² to match the ceiling lamps.

Articolo Item	Lunghezza Length		€
LNK.CC15	circa approx cm 15	10	1,60
LNK.CC50	circa approx cm 50	10	1,96
LNK.CC200	circa approx cm 200	10	4,88

Accessori per plafoniere

Accessories for ceiling lamps



Cavo di raccordo H03 VV H2-F 2 x 0,75 mm² con innesti M/F a squadra 90°

Connecting cable H03 VV H2-F 2 x 0.75 mm² with M/F square inserts 90°

Articolo Item	Lunghezza Length		€
LNK.CC15.PP	circa approx cm 15	10	1,90
LNK.CC50.PP	circa approx cm 50	10	3,45
LNK.CC100.PP	circa approx cm 100	10	4,67

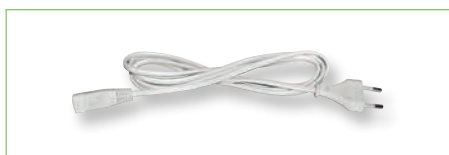

Cavo di alimentazione H03 VV H2-F 2 x 0,75 mm² con spina ed innesto dritto

Power supply cord H03 VV H2-F 2 x 0.75 mm² with plug and straight insert

Articolo Item	Lunghezza Length		€
LNK.170	circa approx cm 170	5	3,85

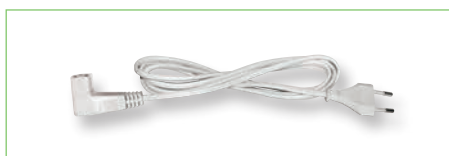

Cavo di alimentazione H03 VV H2-F 2 x 0,75 mm² con spina ed innesto a squadra 90°

Power supply cord H03 VV H2-F 2 x 0.75 mm² with plug and square insert 90°

Articolo Item	Lunghezza Length		€
LNK.PP	circa approx cm 170	5	3,61



Clip in metallo per il fissaggio delle plafoniere LNK con corpo in policarbonato

Metal clips for fixing LNK ceiling lamps with body in polycarbonate

Articolo Item	Descrizione Description		€
LNK.CLIP	Clip per plafoniere LNK Clips for LNK ceiling lamps	20	0,44



Clip in plastica per il fissaggio delle plafoniere TTL e PTL

Plastic clips for fixing TTL and PTL ceiling lamps.

Articolo Item	Descrizione Description		€
TTL.CLIP	Clip per plafoniere TTL e PTL Clips for TTL and PTL ceiling lamps	20	0,89

GIRKO



- Base in tecnopolimero
- Diffusore in policarbonato satinato
- Vano posteriore per cablaggio elettrico, dotato di 3 entrate sfondabili per il montaggio di pressacavi PG16 o di raccordo tubo-scatoia Ø16mm
- Alimentazione: 220÷240V ~ 50/60Hz
- Resa cromatica: >80
- Efficienza luminosa: 80lm/W
- Fattore di potenza: >0,9
- Temperatura di funzionamento: -20 +40°C
- Apertura fascio: 110°
- Vita media: 30.000 ore
- Classe d'isolamento: II □
- Impermeabile, per montaggio all'esterno IP54
- Resistente agli urti: IK06

- Base in technopolymer
- Satin polycarbonate diffuser
- Rear compartment for electrical connection, with 3 knockout inputs for mounting of cable glands PG16 or connection tube-box Ø16mm
- Power supply: 220÷240V ~ 50/60Hz
- Colour rendering: >80
- Luminous efficiency: 80lm/W
- Power factor: >0,9
- Working temperature: -20 +40°C
- Beam angle: 110°
- Average life: 30.000 hours
- Insulation class: II □
- Waterproof, for outdoor IP54
- Shockproof: IK06



OVALE | OVAL

Articolo Item	Watt	Lumen	Temperatura colore Colour temperature	Equivalente alogena Equivalent halogen	Apertura fascio Beam angle	Dimensioni Dimensions	□	€
GKO8.D	8	640	4000°K	75 W	110°	168 x 77 x 92 mm	10	9,68
GKO12.D	12	960	4000°K	100 W	110°	215 x 77 x 118 mm	10	12,75

TONDA | ROUND

Articolo Item	Watt	Lumen	Temperatura colore Colour temperature	Equivalente alogena Equivalent halogen	Apertura fascio Beam angle	Dimensioni Dimensions	□	€
GKT8.D	8	640	4000°K	75 W	110°	Ø 149 x 80 mm	10	9,68
GKT12.D	12	960	4000°K	100 W	110°	Ø 190 x 80 mm	10	12,75

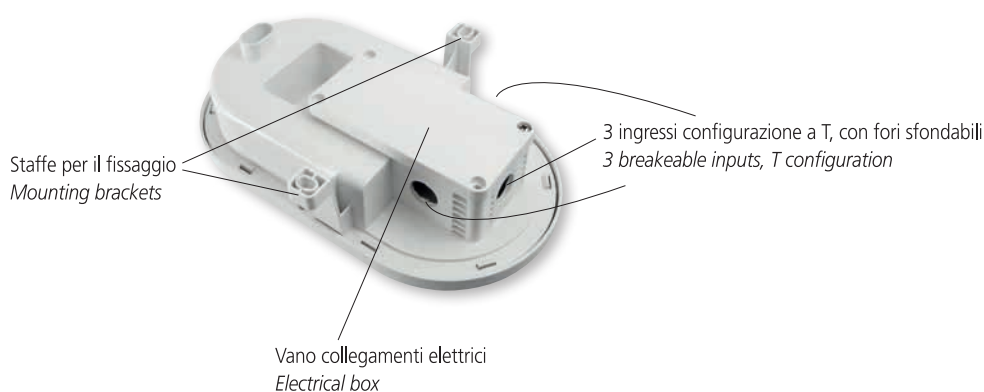

Plafoniere ovali di produzione tedesca

Ceiling lamps oval, German produced

LYVIA

IP44 CL. II    

3 ENTRATE | 3 INPUTS

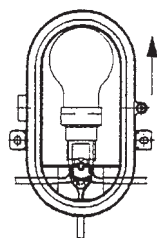

- Base in materiale termoplastico, autoestinguente
- gabbia di protezione in metallo galvanizzato
- riflettore in alluminio
- coppa in vetro prismatico
- colore grigio RAL 7035
- portalampada E 27 in porcellana
- 3 entrate sfondabili per raccordo stagno tubo-scatoia Ø 16 mm o da Ø 20 mm

- Base in thermoplastic material, self-extinguishing
- protection screen in galvanised metal
- aluminium reflector
- cup in prismatic glass
- RAL 7035 grey
- E 27 lamp holder in porcelain
- 3 knockout inputs for waterproof connection tube-box Ø 16 mm or Ø 20 mm



Articolo Item	Watt	Dimensioni Dimensions		€
52.1200.0002	max 100	134 x 193 x 115 mm	10	7,98



LED MOUSE

Con interruttore ON-OFF

2 led bianco diurno (4000°K)
CRI: > 80
Spina 2 P+ T 2,5 A asse verticale
Corpo in policarbonato

With ON-OFF switch

2 daylight LEDs (4000°K)
CRI: > 80
Plug 2 P+ T 2.5 A vertical axis
Body in polycarbonate

Articolo Item	Dimensioni Dimensions	Alimentazione Power supply	Lumen	Watt		€
*HL037	82 x 44 x 58 mm	230 V~ 50Hz	4	0,4	12	4,38



LITE MOUSE

Con sensore crepuscolare

2 led bianco diurno (4000°K)
CRI: > 80
Spina 2 P+ T 2,5 A asse verticale
Corpo in policarbonato

With twilight sensor

2 daylight LEDs (4000°K)
CRI: > 80
Plug 2 P+ T 2.5 A vertical axis
Body in polycarbonate

Articolo Item	Dimensioni Dimensions	Alimentazione Power supply	Lumen	Watt		€
*HL032	82 x 44 x 58 mm	230 V~ 50Hz	4	0,4	12	4,89



Q NITE

Con interruttore ON-OFF

1 led bianco diurno (4000°K)
CRI: > 80
Spina 2 P+ T 2,5 A asse verticale
Corpo in policarbonato

With ON-OFF switch

1 daylight LED (4000°K)
CRI: > 80
Plug 2 P+ T 2.5 A vertical axis
Body in polycarbonate

Articolo Item	Dimensioni Dimensions	Alimentazione Power supply	Lumen	Watt		€
*HL043	54 x 54 x 50 mm	230 V~ 50Hz	7	0,3	12	4,21



SENSOR LITE

Luce automatica a spina.

Con rilevatore di presenza per l'accensione automatica al passaggio della persona.

Con sensore crepuscolare e luce notte.

Doppia luce:

- posteriore per illuminazione di sicurezza
- nite lite frontale per illuminazione di cortesia

CRI: > 80

Spina 2 P+ T 2,5 A asse verticale

Corpo in policarbonato

Automatic plug-in light.

With motion sensor for automatically switching on when a person passes by.

With twilight sensor and night light.

Double light:

- rear for safety lighting
- frontal nite lite for courtesy lighting

CRI: > 80

Plug 2 P+ T 2.5 A vertical axis

Body in polycarbonate



Articolo Item	Dimensioni Dimensions	Alimentazione Power supply	Lumen	Watt		€
*HL006	57 x 54 x 114 mm	230 V~ 50Hz	50	1,8	10	12,80

Lampade veglia notturna

Night light

LYVIA



LYVIALITE



Luce notturna in policarbonato autoestinguente corredata di lampada fluorescente miniaturizzata a risparmio energetico (non sostituibile)

Con interruttore ON-OFF

Spina bipolare 2,5 A ad asse verticale

Night light in self-extinguishing polycarbonate equipped with miniature fluorescent energy saving lamp (non replaceable)

With ON-OFF switch

Two-pole plug 2.5 A with vertical axis

Articolo Item	Dimensioni Dimensions	Alimentazione Power supply	Watt	Colore Colour		€
* NL.001	70 x 60 x 28 mm	230 V~ 50Hz	1	Bianco White	6	4,14

Lampada fluorescente multiuso

Multi-purpose fluorescent lamp



CE IP20

Lampada fluorescente multiuso

Corredata di gancio da appendere, supporto da tavolo

- Corpo in ABS bianco ghiaccio
- Interruttore a bilancere ON-OFF
- Ballast elettronico
- Lampada PL9W **non sostituibile**
- Cavo di alimentazione H03 VV2-F 2 x 0,75 mm² con spina, lunghezza 170 cm circa
- Durata della lampada: 6000 ore

Uno speciale supporto (in dotazione) permette di usare questa lampada come lampada da tavolo o da comodino.

Multi-purpose fluorescent lamp

Equipped with hanging hook, table support

- Body in polar white ABS
- ON-OFF rocker switch
- Electronic ballast
- **Non replaceable** PL9W lamp
- Power supply cord H03 VV2-F 2 x 0.75 mm² with plug, length 170 cm approx.
- Lamp life: 6000 hours

A special support (included) lets you use this lamp as table or bedside lamp.



Articolo Item	Dimensioni Dimensions	Alimentazione Power supply	Watt	Colore Colour		€
TL.3001	60 x 210 x 25 mm	230 V~ 50Hz	9	Bianco ghiaccio Polar white	12	6,47

Lampada da Tavolo Led

Led table lamp

LYVIALED



Smart



Inquadra il Qr Code con il tuo smartphone
Aim QR code with your smartphone

- Design moderno e funzionale
- Testa e stelo della lampada possono essere orientati, permettendo una regolazione più precisa del flusso luminoso
- Dotata di pannello comandi touch con memoria impostazione parametri di luminosità e colore
- Diffusore led dalla particolare forma antiabbagliamento
- Sensore crepuscolare, consente accensioni e spegnimenti graduali e solo nelle corrette condizioni di luce
- **RICARICA IL CELLULARE** se il vostro cellulare è predisposto, potete semplicemente appoggiarlo sul centro della base della lampada ed effettuare la ricarica. Se il vostro cellulare non è predisposto potrete ricaricarlo in modalità wireless utilizzando l'adattatore fornito in dotazione.
- Alimentazione: 110V-240Vc.a./12c.c. 2A (tramite apposito alimentatore)
- Potenza: 10W
- Flusso luminoso: 700 lm regolabile
- Illuminamento: 1.200 lux (a 30 cm)
- Temperature di colore: bianco puro 5.500°K
bianco diurno 4.000°K
bianco caldo 3.000°K
- CRI: ≥80, dona brillantezza agli oggetti
- Porta USB: 5V - 1A per ricarica cellulare e/o tablet
- Timer spegnimento: 60 min.
- Luce notte
- Corpo: Alluminio satinato e ABS bianco, ad alta resistenza agli urti
- *Modern and functional design*
- *Head and bracket can be oriented, allowing more precise beam angle regulation*
- *With touch controls panel, with memory of brightness and colour settings*
- *Led diffuser with particular shape anti-dazzle*
- *Twilight sensor, allows gradual light on and off, only in correct light conditions*
- **MOBILE PHONE RECHARGE:** if your mobile phone is compatible, you can recharge it only placing it on the centre of the lamp's base. If your mobile phone is not compatible, you can recharge it in wireless mode using the adaptor (supplied with the lamp).
- *Power supply voltage: 110-240V AC / 12 DC 2A (with specific driver)*
- *Consumption: 10W*
- *Luminous flux: 700 lm dimmable*
- *Lighting: 1.200 lux (at 30 cm)*
- *Colour temperatures: pure white 5.500°K
daylight 4.000°K
warm white 3.000°K*
- *CRI: ≥80, gives brightness at objects*
- *USB socket: 5V - 1A for phone and/or tablet recharge*
- *Switching off timer: 60 min.*
- *Night light*
- *Body: satin aluminium and white ABS, high shockproof*



Articolo Item	Colore corpo Body colour	Watt	Lumen	Temp. colore Colour temp.	Aper. fascio Beam angle	Dimensioni Dimensions		€
DEL.41	Bianco e alluminio White and aluminium	10W	700	da 3.000°K a 5500°K from 3.000°K to 5500°K	120°	455 x 123 mm	1/4	112,95

Pannello touch Touch panel



Sensore crepuscolare Twilight sensor



Ricarica wireless Wireless recharge



Diffusore antiabbagliamento Anti-dazzle diffuser

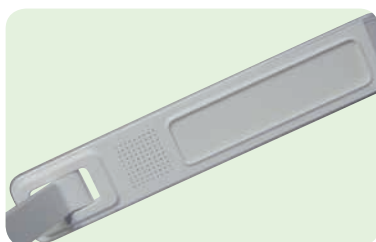

Porta USB USB Socket



Luce notte Night light



SONDE E UTENSILI

FISH TAPE AND TOOLS





Per infilaggio nei tubi rigidi e flessibili

For drawing in stiff and flexible pipes



Sonda in materiale plastico polimero, auto lubrificante, dalla speciale sezione "a monospirale", diametro 3 mm.

Fish tape in polymer plastic material, self-lubricating, with special "single spiral" section, diameter 3 mm.

Capace di ridurre l'attrito, in quanto riduce al minimo la superficie di contatto della sonda con le pareti del tubo da infilare, o con i cavi già presenti nella condotta. Inoltre, la costruzione del monofilo ne aumenta la rigidità. Su entrambe le estremità della sonda è montato un puntale flessibile con asola in modo da permettere il fissaggio e traino dei cavi da ambedue le parti. Le parti d'ottone sono di spessore ridotto per garantire le massime performances della sonda.

Able to reduce friction, as it reduces to the minimum the contact surface of the fish tape with the walls of the pipe to be drawn, or with the cables already in the duct. Furthermore, single wire construction increases stiffness. On both the fish tape ends is provided one flexible terminal with hole for wires hanging on both ends. The brass components are in reduced thickness for maximize the fish tape performances.

Ø 3 mm.
Ideale per l'infilaggio in tubi di piccolo diametro: 20-25 mm

Ø 3 mm.
Ideale for drawing in small diameter pipes: 20-25 mm

- colore verde lucido
- con 2 puntali guidacurve flessibili forati in punta
- nessuna conducibilità elettrica

- glossy light green
- with 2 interchangeable flexible perforated tips
- no electrical conductivity

Articolo Item	Dimensioni Dimensions		€
4319.10	Lunghezza 10 m. circa Length 10 m. approx.	5	60,35
4319.15	Lunghezza 15 m. circa Length 15 m. approx.	5	78,30



Per infilaggio nei tubi rigidi e flessibili

For drawing in stiff and flexible pipes



Sonda in materiale plastico polimero, auto-lubrificante, dalla speciale sezione "a spirale", diametro 4,5 mm.

Fish tape in polymer plastic material, self-lubricating, with special "spiral" section, diameter 4,5 mm.

Capace di ridurre l'attrito, in quanto riduce al minimo la superficie di contatto della sonda con le pareti del tubo da infilare, o con i cavi già presenti nella condotta. I terminali della sonda sono in ottone filettato M5 e consentono la facile intercambiabilità dei vari accessori.

Able to reduce friction, as it reduces to the minimum the contact surface of the fish tape with the walls of the pipe to be drawn, or with the cables already in the duct. The fish tape terminals are in M5 threaded brass and assure easy interchangeability of the various accessories.

- Ø 4,5 mm.
- Ideale per l'infilaggio in tubi di piccolo diametro: 20-25 mm
- colore giallo
- con puntale guidacurve flessibile forato in punta e tirante con asola intercambiabili
- nessuna conducibilità elettrica

- Ø 4,5 mm.
- Ideal for drawing in small diameter pipes: 20-25 mm
- yellow
- with interchangeable flexible perforated tip starting spinner and pulling loop with eyelet
- no electrical conductivity

Articolo Item	Dimensioni Dimensions		€
4519.10	Lunghezza 10 m. circa Length 10 m. approx.	5	47,15
4519.15	Lunghezza 15 m. circa Length 15 m. approx.	5	64,85
4519.20	Lunghezza 20 m. circa Length 20 m. approx.	5	83,65
4519.25Y	Lunghezza 25 m. circa Length 25 m. approx.	5	105,10

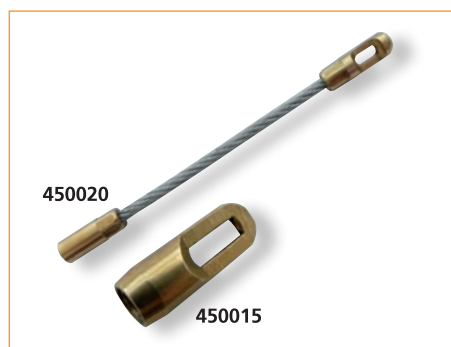

Accessori | Accessories

Puntale flessibile con asola
Testa in ottone Ø 9 mm
con filetto M5

Flexible tip with eyelet
Brass head Ø 9 mm
with M5 thread

Tirante con asola
con filetto M5

Pulling loop with eyelet
with M5 thread

Articolo Item	Descrizione Description		€
450020	Puntale flessibile, Ø 9 mm Flexible tip, Ø 9 mm	10	6,95
450015	Tirante con asola Pulling loop with eyelet	5	4,28

Per gli accessori si veda pag. 55 | For accessories see pag. 55



Per infilaggio nei tubi rigidi e flessibili

For drawing in stiff and flexible pipes



Sonda in materiale plastico polimero, auto lubrificante, dalla speciale sezione "a monospirale", diametro 4,5 mm.

Fish tape in polymer plastic material, self-lubricating, with special "single spiral" section, diameter 4.5 mm.

Capace di ridurre l'attrito, in quanto riduce al minimo la superficie di contatto della sonda con le pareti del tubo da infilare, o con i cavi già presenti nella condotta. Inoltre, la costruzione del monofilo ne aumenta la rigidità. I terminali della sonda sono in ottone filettato M5 e consentono la facile intercambiabilità dei vari accessori.

Able to reduce friction, as it reduces to the minimum the contact surface of the fish tape with the walls of the pipe to be drawn, or with the cables already in the duct. Furthermore, single wire construction increases stiffness. The fish tape terminals are in M5 threaded brass and assure easy interchangeability of the various accessories.

Ø 4,5 mm.
Ideale per l'infilaggio in tubi di piccolo diametro: 20-25 mm

Ø 4,5 mm.
Ideal for drawing in small diameter pipes: 20-25 mm

- colore arancione lucido
- terminali filettati M5
- con puntale guidacurve flessibile forato in punta e tirante con asola intercambiabili
- nessuna conducibilità elettrica

- glossy orange
- M5 threaded terminals
- with interchangeable flexible perforated tip starting spinner and pulling loop with eyelet
- no electrical conductivity

Articolo Item	Dimensioni Dimensions		€
4819.10	Lunghezza 10 m. circa Length 10 m. approx.	5	43,50
4819.15	Lunghezza 15 m. circa Length 15 m. approx.	5	59,80
4819.20	Lunghezza 20 m. circa Length 20 m. approx.	5	77,10
4819.25	Lunghezza 25 m. circa Length 25 m. approx.	5	91,20

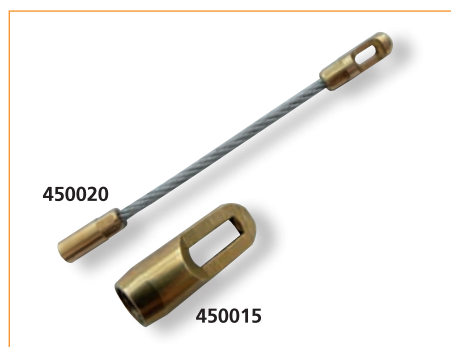

Accessori | Accessories

Puntale flessibile con asola
Testa in ottone Ø 9 mm
con filetto M5

Flexible tip with eyelet
Brass head Ø 9 mm
with M5 thread

Tirante con asola
con filetto M5

Pulling loop with eyelet
with M5 thread

Articolo Item	Descrizione Description		€
450020	Puntale flessibile, Ø 9 mm Flexible tip, brass Ø 9 mm	10	6,95
450015	Tirante con asola Pulling loop with eyelet	5	4,28

Per gli accessori si veda pag. 55 | For accessories see pag. 55

Sonde speciali «HURRICANE»

«HURRICANE» special fish tape

LYVIA



HURRY UP

Contenitore per le sonde HURRICANE

- in policarbonato
- doppio gancio
- pratica manopola per un veloce riavvolgimento
- fornito completo di sonda, puntale e tirante

Case for HURRICANE fish tape

- in polycarbonate
- double hook
- handy knob for quick rewinding
- supplied complete with fish tape, tip and pulling loop

Articolo Item	Dimensioni Dimensions		€
HU.10	Lunghezza 10 m. Length 10 m. approx.	5	123,40
HU.15	Lunghezza 15 m. Length 15 m. approx.	5	146,65
HU.20	Lunghezza 20 m. Length 20 m. approx.	5	156,00
HU.25	Lunghezza 25 m. Length 25 m. approx.	5	174,70

Accessori per sonde «TWISTY» e «HURRICANE»

Accessories for «TWISTY» and «HURRICANE» fish tape



CALZE | PULLING GRIPS

Calze per impianti civili

- in acciaio zincato
- provviste di tirante filettato M5

Pulling grips for civil installations

- in galvanised steel
- fitted with M5 threaded pulling loop

Articolo Item	Dimensioni Dimensions		€
* 108066	Calza con tirante per cavi Ø 4÷6 mm Grip with pulling loop for Ø 4÷6 mm cables	1	17,00
* 108060	Calza con tirante per cavi Ø 6÷9 mm Grip with pulling loop for Ø 6÷9 mm cables	1	18,15



LYVIAGRIP

Pratico attrezzo in gomma termoplastica per tirare le sonde tonde di nylon da Ø 3 a 6 mm

Handy tool in thermoplastic rubber to pull Ø 3 to 6 mm round nylon fish tape

Articolo Item	Dimensioni Dimensions		€
101370	Tirasonda Lyviagrip Lyviagrip fish tape puller	1	5,31



Per infilaggio in cavidotti

For drawing in wire conduits

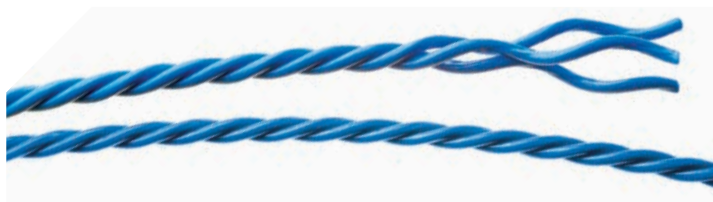

Sonda in materiale plastico polimero, auto-lubrificante, dalla speciale sezione "a spirale", diametro 5,2 mm.

Capace di ridurre l'attrito, in quanto riduce al minimo la superficie di contatto della sonda con le pareti del tubo da infilare, o con i cavi già presenti nella condotta. I terminali della sonda sono in ottone filettato M5 e consentono la facile intercambiabilità dei vari accessori.

- Ø 5,2 mm.
- colore blu
- con puntale guidacurve flessibile forato in punta e tirante con asola intercambiabili
- nessuna conducibilità elettrica

Fish tape in polymer plastic material, self-lubricating, with special "spiral" section, diameter 5,2 mm.

Able to reduce friction, as it reduces to the minimum the contact surface of the fish tape with the walls of the pipe to be drawn, or with the cables already in the duct. The fish tape terminals are in M5 threaded brass and assure easy interchangeability of the various accessories.

- Ø 5,2 mm.
- blue
- with interchangeable flexible perforated tip starting spinner and pulling loop with eyelet
- no electrical conductivity

Articolo Item	Dimensioni Dimensions		€
4519.25	Lunghezza 25 m. circa Length 25 m. approx.	5	121,15
4519.30	Lunghezza 30 m. circa Length 30 m. approx.	3	142,00
4519.40	Lunghezza 40 m. circa Length 40 m. approx.	3	183,50
4519.50	Lunghezza 50 m. circa Length 50 m. approx.	3	225,05
4519.60	Lunghezza 60 m. circa Length 60 m. approx.	3	266,60

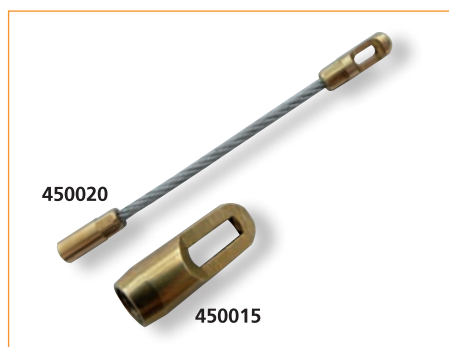

Accessori | Accessories

Puntale flessibile con asola
Testa in ottone Ø 9 mm
con filetto M5

Flexible tip with eyelet
Brass head Ø 9 mm
with M5 thread

Tirante con asola
con filetto M5

Pulling loop with eyelet
with M5 thread

Articolo Item	Descrizione Description		€
450020	Puntale flessibile, Ø 9 mm Flexible tip, Ø 9 mm	10	6,95
450015	Tirante con asola Pulling loop with eyelet	5	4,28

Per gli accessori si veda pag. 55 | For accessories see pag. 55



Per infilare i conduttori nei tubi rigidi o flessibili

- SONDA PERLON® Ø 4 mm**
Costruite in PERLON®, con elevate caratteristiche meccaniche, di lunga durata, indeformabile.
Ø 4 mm
- flessibile, con normale facilità di introduzione nei tubi Ø 20-25 mm
 - colore trasparente
 - con puntale guidacurve flessibile e tirante con asola intercambiabili
 - nessuna conducibilità elettrica

To draw conductors in stiff or flexible pipes

- PERLON® Ø 4 mm FISH TAPE**
Constructed in PERLON®, with high mechanical features, long duration, nondeformable.
Ø 4 mm
- flexible, with normal ease of introduction in pipes Ø 20-25 mm
 - transparent
 - with interchangeable flexible starting spinner and pulling loop with eyelet
 - no electrical conductivity

Articolo Item	Dimensioni Dimensions		€
4219.05	Lunghezza 5 m. circa Length 5 m. approx.	20	4,15
4219.10	Lunghezza 10 m. circa Length 10 m. approx.	20	5,91
4219.15	Lunghezza 15 m. circa Length 15 m. approx.	20	8,10
4219.20	Lunghezza 20 m. circa Length 20 m. approx.	10	10,50
4219.25	Lunghezza 25 m. circa Length 25 m. approx.	10	12,65
4219.30	Lunghezza 30 m. circa Length 30 m. approx.	10	15,10



Accessori | Accessories

Articolo Item	Descrizione Description		€
037900	Puntale flessibile - filetto M4 Flexible tip - M4 thread	10	2,12
060290	Tirante con asola - filetto M4 Pulling loop with eyelet - M4 thread	10	0,84
037950	Puntale flessibile con asola - filetto M4 Flexible tip with eyelet - M4 thread	10	4,10



Per infilare i conduttori nei tubi rigidi o flessibili

- SONDA IN NYLON Ø 3 mm**
- flessibile con normale facilità di introduzione nei tubi Ø 16-20 mm
 - con puntale guidacurve in acciaio flessibile
 - occhio posteriore per tiraggio dei fili
 - nessuna conducibilità elettrica

To draw conductors in stiff or flexible pipes

- NYLON Ø 3 mm FISH TAPE**
- flexible with normal ease of introduction in pipes Ø 16-20 mm
 - with starting spinner in flexible steel
 - rear eyelet for wire pulling
 - no electrical conductivity

Articolo Item	Dimensioni Dimensions		€
2219.10	Lunghezza 10 m. circa Length 10 m. approx.	20	3,84
2219.15	Lunghezza 15 m. circa Length 15 m. approx.	20	4,96
2219.20	Lunghezza 20 m. circa Length 20 m. approx.	10	6,37



Per infilare i conduttori nei tubi rigidi o flessibili

SONDA PERLON® Ø 4 mm
Costruite in PERLON®, un materiale di produzione tedesca, con elevate caratteristiche meccaniche, di lunga durata, indeformabile.
Ø 4 mm

- flessibile, con normale facilità di introduzione nei tubi Ø 20-25 mm
- colore nero lucido
- con puntale guidacurve flessibile e tirante con asola intercambiabili
- nessuna conducibilità elettrica

To draw conductors in stiff or flexible pipes

PERLON® Ø 4 mm FISH TAPE
Constructed in PERLON®, a German-produced material, with high mechanical features, long duration, nondeformable.
Ø 4 mm

- flexible, with normal ease of introduction in pipes Ø 20-25 mm
- glossy black
- with interchangeable flexible starting spinner and pulling loop with eyelet
- no electrical conductivity

Articolo Item	Dimensioni Dimensions		€
4919.05	Lunghezza 5 m. circa Length 5 m. approx.	20	6,71
4919.10	Lunghezza 10 m. circa Length 10 m. approx.	20	8,39
4919.15	Lunghezza 15 m. circa Length 15 m. approx.	20	10,50
4919.20	Lunghezza 20 m. circa Length 20 m. approx.	10	13,10
4919.25	Lunghezza 25 m. circa Length 25 m. approx.	10	14,95
4919.30	Lunghezza 30 m. circa Length 30 m. approx.	10	16,75



Accessori | Accessories

Articolo Item	Descrizione Description		€
037900	Puntale flessibile - filetto M4 Flexible tip - M4 thread	10	2,12
060290	Tirante con asola - filetto M4 Pulling loop with eyelet - M4 thread	10	0,84
037950	Puntale flessibile con asola - filetto M4 Flexible tip with eyelet - M4 thread	10	4,10



LYVIAGRIP

Pratico attrezzo in gomma termoplastica per tirare le sonde tonde di nylon da Ø 3 a 6 mm

Handy tool in thermoplastic rubber to pull Ø 3 to 6 mm round nylon fish tape

Articolo Item	Descrizione Description		€
101370	Tirasonda Lyviagrip Lyviagrip fish tape puller	1	5,31

Per gli accessori si veda pag. 59 | For accessories see pag. 59



Per infilare i conduttori nei tubi rigidi o flessibili

To draw conductors in stiff or flexible pipes

SONDA IN FIBRA DI VETRO Ø 3 mm

FIBERGLASS Ø 3 mm FISH TAPE

- completa di puntale guidacurve in acciaio flessibile e terminale ad occhiello
- altissima flessibilità di introduzione nei tubi Ø 16-50 mm
- bassa facilità di curvatura
- con terminali in ottone M5
- nessuna conducibilità elettrica

- complete with spinner in flexible steel and eyelet terminal
- extremely high flexibility in pipe insertion Ø 16-50 mm
- low ease of curvature
- with M5 brass terminals
- no electrical conductivity

Articolo Item	Dimensioni Dimensions		€
3039.10	Lunghezza 10 m. circa Length 10 m. approx.	20	27,70
3039.15	Lunghezza 15 m. circa Length 15 m. approx.	10	33,00
3039.20	Lunghezza 20 m. circa Length 20 m. approx.	10	38,15
3039.25	Lunghezza 25 m. circa Length 25 m. approx.	5	44,30

Accessori per sonde Lyviafil

Accessories for Lyviafil fish tape

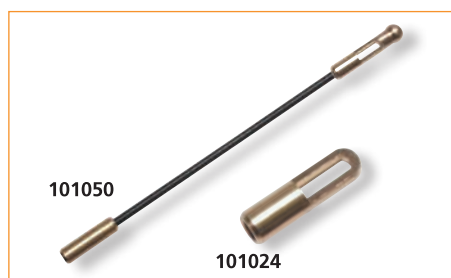

Articolo Item	Descrizione Description		€
101050	Puntale flessibile con asola - filetto M5 Flexible tip with eyelet - M5 thread	3	6,30
101024	Tirante con asola - filetto M5 Pulling loop with eyelet - M5 thread	5	2,26

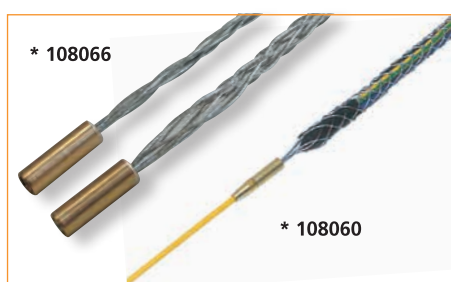

- Calze per impianti civili**
- in acciaio zincato
 - provviste di tirante filettato M5
 - usare con l'adattatore Art. 060292 per sonde in nylon filetto M4

- Pulling grips for civil installations**
- in galvanised steel
 - fitted with M5 threaded pulling loop
 - use with adapter item 060292 for nylon fish tape M4 thread

Articolo Item	Descrizione Description		€
* 108066	Calza con tirante per cavi Ø 4÷6 mm Grip with pulling loop for Ø 4÷6 mm cables	1	17,00
* 108060	Calza con tirante per cavi Ø 6÷9 mm Grip with pulling loop for Ø 6÷9 mm cables	1	18,15



- Adattatore**
- Per permettere il collegamento delle calze con tirante M5 con la sonda Lyviafil M4
- filetto maschio M5
 - filetto femmina M4

- Adapter**
- For connecting grips with M5 pulling loop with the Lyviafil M4 fish tape
- M5 male thread
 - M4 female thread

Articolo Item	Descrizione Description		€
* 060292	Adattatore M5/M4 per sonde M5/M4 adapter for fish tape	10	0,87

Sonde «LyviaBlitz»

«LyviaBlitz» fish tape



LYVIA

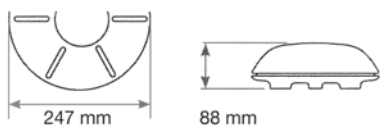

Esempio di impiego: | Example of application:

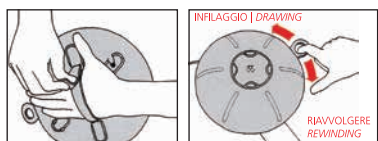

LYVIA Blitz

Sonda passacavi in fibra di vetro Ø 3 mm, con rivestimento in PP, completa di raccordi M5 e accessori 101024 (tirante) 101050 (puntale flessibile con asola) 101370 (tirasonda).

Esecuzione **base** corredata dei seguenti accessori:
 1 pz. tirante art. 101024
 1 pz. puntale art. 101050
 1 pz. tirasonda art. 101370

Fiberglass fish tape Ø 3 mm, with coating in PP, complete with M5 connections and accessories 101024 (pulling loop) 101050 (flexible tip with eyelet) 101370 (tape puller).

Basic construction equipped with the following accessories:
 1 pc. pulling loop item 101024
 1 pc. tip item 101050
 1 pc. tape puller item 101370

Articolo Item	Descrizione Description		€
101820	Contenitore con sonda in fibra di vetro Ø 3 mm 20 m Case with fish tape in glass fibre Ø 3 mm 20 m	1	117,30
101830	Contenitore con sonda in fibra di vetro Ø 3 mm 30 m Case with fish tape in glass fibre Ø 3 mm 30 m	1	136,10
101800	Contenitore vuoto, adatto per avvolgere sino a 40 m di sonde Ø 3 mm o Ø 4 mm in fibra di vetro, nylon, perlon Empty case, suitable to wind up to 40 m fish tape Ø 3 mm or Ø 4 mm in glass fibre, nylon, perlon	1	73,70

Ricambi & accessori | Spare parts & accessories



Vergella in fibra di vetro
 completa di terminali filettati M5

Wire rod in glass fibre
 complete with M5 threaded terminals

Articolo Item	Diametro Diameter	Lunghezza Length		€
101320	Ø 3	20	1	37,05
101330	Ø 3	30	1	49,10

Accessori per Sonde «LyviaBlitz»

Accessories for «LyviaBlitz» Fish Tape



LYVIA



Puntale flessibile

- con filetto M5
- testa in ottone

Flexible tip

- with M5 thread
- brass head

Articolo Item	Dimensioni Dimensions		€
101050	Ø 6 mm con asola Ø 6 mm with eyelet	3	6,30
101053	Ø 7 mm	5	6,83
101054	Ø 10 mm	3	6,83
101055	Ø 13 mm	3	6,83



Tirante

- con filetto M5 con asola

Pulling loop

- with M5 thread with eyelet

Articolo Item	Descrizione Description		€
101024	Tirante con asola Pulling loop with eyelet	5	2,26



Terminale filettato

- con filetto M5
- Ø 3 mm

Threaded terminal

- with M5 thread
- Ø 3 mm

Articolo Item	Descrizione Description		€
101023	Terminale filettato Ø 3 mm Threaded terminal Ø 3 mm	2	2,21



Congiuntore

- per riparazione
- Ø 3 mm

Joint

- for repair
- Ø 3 mm

Articolo Item	Descrizione Description		€
101025	Congiuntore Ø 3 mm Joint Ø 3 mm	2	2,16



Collante

- speciale rapido LYVIAFIX 3 gr

Glue

- special quick glue LYVIAFIX 3 gr

Articolo Item	Descrizione Description		€
101027	Confezione in boccetta da 3 gr In 3 gr bottle	1	7,07



Per impieghi industriali

Robusta anima piatta in acciaio temperato blu
 ▣ 4x1,5 mm; rivestimento esterno in nylon

∅ 6 mm

- colore giallo
- con perni filettati M5 per l'intercambiabilità degli accessori
- puntale e tirante fresati
- adatte per lunghi percorsi

For industrial use

Sturdy flat core in tempered blue steel
 ▣ 4x1.5 mm; external nylon coating

∅ 6 mm

- yellow
- with M5 threaded pins for interchangeability of accessories
- milled tip and pulling loop
- suitable for long path

Articolo Item	Dimensioni Dimensions		€
6219.20	Lunghezza 20 m. circa Length 20 m. approx.	1	57,05
6219.30	Lunghezza 30 m. circa Length 30 m. approx.	1	80,45
6219.40	Lunghezza 40 m. circa Length 40 m. approx.	1	97,25
6219.50	Lunghezza 50 m. circa Length 50 m. approx.	1	118,40
6219.60	Lunghezza 60 m. circa Length 60 m. approx.	1	143,40



Ricambi & accessori | Spare parts & accessories

Puntale flessibile

Con filetto M5
 Diametro testa: ∅ 10 mm

Flexible tip

With M5 thread
 Head diameter: ∅ 10 mm

Puntale / tirante

Con filetto M5
 Diametro testa: ∅ 11 mm

Tip / pulling loop

With M5 thread
 Head diameter: ∅ 11 mm

Articolo Item	Descrizione Description		€
060295	Puntale flessibile ∅ 10 mm Flexible tip ∅ 10 mm	5	21,10
060291	Puntale / Tirante ∅ 11 mm Tip / pulling loop ∅ 11 mm	3	9,67

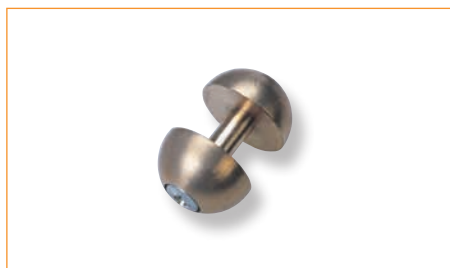

Ruota di scorrimento
Da montare sul puntale in dotazione
Diametro max: 32 mm

Sliding wheel
To be fitted on the supplied tip
Max. diameter: 32 mm

Articolo Item	Descrizione Description		€
060297	Ruota di scorrimento Sliding wheel	3	8,83



Grillo d'aggancio
in acciaio, abbinabile ai puntali/tiranti

Hooking shackle
in steel, to be combined with the tips/pulling loops

Articolo Item	Descrizione Description		€
100490	Grillo d'aggancio per Art. 060291 Hooking shackle for item 060291	1	5,35
100491	Grillo d'aggancio per Art. 060293 Hooking shackle for item 060293	1	7,52



ASPO | REEL

Orizzontale Ø 600 mm

- in acciaio con zincatura tropicalizzata
- montato su bussola ruotante
- con guida per svolgere e riavvolgere la sonda
- vuoto, adatto per avvolgere le sonde Lyviaforte
- Ø 6 fino a 60 m di lunghezza
- Ø 10 fino a 40 m di lunghezza

Horizontal Ø 600 mm

- in steel with tropicalised zinc plating
- mounted on rotating bush
- with guide for unwinding and rewinding the fish tape
- empty, suitable for winding up Lyviaforte fish tape
- Ø 6 up to 60 m length
- Ø 10 up to 40 m length

Articolo Item	Descrizione Description		€
600	Aspo vuoto Ø 600 mm Empty reel Ø 600 mm	1	116,90



Per impieghi industriali

Robusta anima piatta in acciaio temperato blu
 ▧ 5x2 mm; rivestimento esterno in nylon

Ø 10 mm

- colore giallo
- con perni filettati M5 per l'intercambiabilità degli accessori
- puntale e tirante fresati
- adatte per lunghi percorsi

For industrial use

Sturdy flat core in tempered blue steel ▧ 5x2 mm;
 external nylon coating

Ø 10 mm

- yellow
- with M5 threaded pins for interchangeability of accessories
- milled tip and pulling loop
- suitable for long path

Articolo Item	Dimensioni Dimensions		€
10219.40	Lunghezza 40 m. circa Length 40 m. approx.	1	267,65
10219.50	Lunghezza 50 m. circa Length 50 m. approx.	1	332,75
10219.60	Lunghezza 60 m. circa Length 60 m. approx.	1	385,80



Ricambi & accessori | Spare parts & accessories

Puntale / tirante
 con filetto M5
 Diametro testa: Ø 20 mm

Tip / pulling loop
 with M5 thread
 Head diameter: Ø 20 mm

Articolo Item	Descrizione Description		€
060293	Puntale / tirante Ø 20 mm Tip / pulling loop Ø 20 mm	3	22,65

Accessori per Sonde speciali «Lyviaforte»

Accessories for special «Lyviaforte» fish tape



Puntale con ruota di scorrimento
 Diametro max: 50 mm

Tip with sliding wheel
 Max. diameter: 50 mm

Articolo Item	Descrizione Description		€
103304	Puntale con ruota di scorrimento Tip with sliding wheel	1	26,65



Grillo d'aggancio
 in acciaio, abbinabile al puntale/tirante Art. 060293

Hooking shackle
 in steel, to be combined with tip/pulling loop item 060293

Articolo Item	Descrizione Description		€
100491	Grillo d'aggancio Hooking shackle	1	7,52

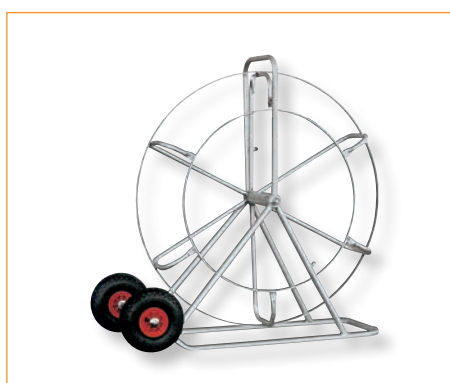

ASPO | REEL

ASPO VERTICALE CARRELLATO (vuoto)
 per sonde LYVIAFORTE Ø 10 mm

VERTICAL WHEELED REEL (empty)
 for LYVIAFORTE fish tape Ø 10 mm

Articolo Item	Descrizione Description		€
103142	Aspo vuoto Ø 800 mm Empty reel Ø 800 mm	1	353,45
103148	Aspo vuoto Ø 1000 mm Empty reel Ø 1000 mm	1	433,65

Sonde in fibra di vetro Ø 4,5 mm

Fiberglass fish tape Ø 4,5 mm



LYVIA



LYVIAMAX

Compatto nucleo in fibra di vetro Ø 3 mm con rivestimento esterno in polipropilene Ø 4,5 mm, colore nero

Compact fiberglass core Ø 3 mm with external polypropylene coating Ø 4.5 mm, black

Sonda avvolta in aspo verticale zincato Ø 330 mm. Corredata di 2 terminali filettati M5, e di 1 puntale/tirante

Wound fish tape in vertical galvanised reel Ø 330 mm. Equipped with 2 M5 threaded terminals, and 1 tip/pulling loop

Articolo Item	Dimensioni Dimensions		€
102022	Lunghezza 20 m. circa Length 20 m. approx.	1	245,75
102023	Lunghezza 30 m. circa Length 30 m. approx.	1	271,40
102024	Lunghezza 40 m. circa Length 40 m. approx.	1	297,05
102025	Lunghezza 50 m. circa Length 50 m. approx.	1	356,55
102028	Lunghezza 80 m. circa Length 80 m. approx.	1	448,30



Ricambi & accessori | Spare parts & accessories

Vergella in fibra di vetro
completa di terminali filettati M5

Fiberglass wire rod
complete with M5 threaded terminals

Articolo Item	Dimensioni Dimensions		€
102032	Lunghezza 20 m. circa Length 20 m. approx.	1	92,40
102033	Lunghezza 30 m. circa Length 30 m. approx.	1	119,40
102034	Lunghezza 40 m. circa Length 40 m. approx.	1	146,35
102035	Lunghezza 50 m. circa Length 50 m. approx.	1	176,75
102038	Lunghezza 80 m. circa Length 80 m. approx.	1	271,50



Puntale / tirante
con filetto M5

Tip / pulling loop
with M5 thread

Articolo Item	Descrizione Description		€
102010	Puntale / tirante Tip / pulling loop	3	7,25



Congiuntore per riparazione
Ø 4,5 mm

Joint for repair
Ø 4,5 mm

Articolo Item	Descrizione Description		€
102009	Congiuntore Ø 4,5 mm Joint Ø 4,5 mm	2	14,15



Giunto girevole
per accoppiamento di 2 sonde in acciaio
con filettature M5

Swivel joint
for connecting 2 steel fish tapes
with M5 thread

Articolo Item	Descrizione Description		€
102055	Giunto girevole Swivel joint	1	24,25



Terminale
con filetto M5

Terminal
with M5 thread

Articolo Item	Descrizione Description		€
102011	Terminale Terminal	2	5,02



Collante bicomponente per riparazione delle sonde in fibra di vetro:
da Ø 4,5 mm, Ø 6 mm, Ø 9 mm e Ø 11 mm

Two-component glue for repairing fiberglass fish tape:
Ø 4,5 mm, Ø 6 mm, Ø 9 mm and Ø 11 mm

Articolo Item	Descrizione Description		€
101028	Confezione in tubetto da 24 ml Package in 24 ml tube	1	38,65



ASPO VUOTO | EMPTY REEL

ASPO VERTICALE (vuoto)
verticale Ø 300 mm

- in acciaio tropicalizzato
- con guida per svolgere o riavvolgere la sonda
- fornito vuoto, adatto per avvolgere le sonde Lyviamax sino a 40 m

VERTICAL REEL (empty)
vertical Ø 300 mm

- in tropicalised steel
- with guide for unwinding or rewinding the fish tape
- supplied empty, suitable for winding up Lyviamax fish tape till 40 m length

Articolo Item	Descrizione Description		€
300	Aspo vuoto Ø 300 mm Empty reel Ø 300 mm	1	93,30

Sonde in fibra di vetro Ø 6 mm

Fiberglass fish tape Ø 6 mm



LYVIA



LYVIAJET

Compatto nucleo in fibra di vetro Ø 4,10 mm con rivestimento esterno in polipropilene Ø 6 mm, colore nero

Compact fiberglass core Ø 4,10 mm with external polypropylene coating Ø 6 mm, black

Sonda avvolta su aspo verticale zincato tropicalizzato Ø 550 mm carrellato.

Fish tape wound on vertical zinc plated tropicalised Ø 550 mm wheeled reel.

Corredato di 2 terminali filettati M6, con 1 puntale / tirante adatto per infilaggi in cavidotti.

Equipped with 2 M6 threaded terminals, with 1 tip / pulling loop suitable for drawing in conduits.

Articolo Item	Dimensioni Dimensions		€
103502	Lunghezza 40 m. circa Length 40 m. approx.	1	332,65
103504	Lunghezza 60 m. circa Length 60 m. approx.	1	389,75
103508	Lunghezza 100 m. circa Length 100 m. approx.	1	600,05



Ricambi & accessori | Spare parts & accessories

Ricambio Ø 6 mm
Vergella completa di terminali filettati M6 colore nero

Replacement Ø 6 mm
Wire rod complete with M6 threaded terminals black

Articolo Item	Dimensioni Dimensions		€
103552	Lunghezza 40 m. circa Length 40 m. approx.	1	225,95
103554	Lunghezza 60 m. circa Length 60 m. approx.	1	314,65
103558	Lunghezza 100 m. circa Length 100 m. approx.	1	451,55



Puntale / tirante Ø 6 mm
con filetto M6

Tip / pulling loop Ø 6 mm
with M6 thread

Articolo Item	Descrizione Description		€
102012	Puntale / tirante Ø 6 mm Tip / pulling loop Ø 6 mm	3	9,08



Congiuntore per riparazione Ø 6 mm

Joint for repair Ø 6 mm

Articolo Item	Descrizione Description		€
103487	Congiuntore Ø 6 mm Joint Ø 6 mm	1	9,08



Giunto girevole
per accoppiamento di 2 sonde in acciaio
con filettature M6

Swivel joint
for connecting 2 steel fish tapes
with M6 thread

Articolo Item	Descrizione Description		€
102056	Giunto girevole Swivel joint	1	26,50



Terminale
con filetto M6

Terminal
with M6 thread

Articolo Item	Descrizione Description		€
103209	Terminale Terminal	1	9,98



Puntale / tirante completo di grillo d'aggancio
abbinabile a tutte le calze con asola
con filetto M6

Tip / pulling loop complete with hooking shackle
to be combined with all pulling grips with eyelet
with M6 thread

Articolo Item	Descrizione Description		€
103300	Puntale / tirante completo di grillo d'aggancio Tip / pulling loop complete with hooking shackle	1	18,15



Puntale con ruota di scorrimento
con filetto M6

Tip with sliding wheel
with M6 thread

Articolo Item	Descrizione Description		€
103301	Puntale con ruota di scorrimento Tip with sliding wheel	1	30,30

Sonde in fibra di vetro Ø 9 - Ø 11 mm

Fiberglass fish tape Ø 9 - Ø 11 mm



LYVIA



LYVIAAL

Sonda industriale con compatto nucleo in fibra di vetro e rivestimento esterno in polipropilene, colore nero

Industrial fish tape with compact fiberglass core and outer polypropylene coating, black

Sonda avvolta su aspo verticale zincato tropicalizzato carrellato.
Corredato di 2 terminali filettati M12 e ruota di scorrimento.

*Fish tape wound on vertical zinc plated tropicalised wheeled reel.
Equipped with 2 M12 threaded terminals and sliding wheel.*

Ø aspo 800 mm carrellato | Ø 800 mm wheeled reel

Articolo Item	Diametro Diameter	Lunghezza Length		€
103042	Ø 9	60 m	1	708,05

Ø aspo 1000 mm carrellato | Ø 1000 mm wheeled reel

Articolo Item	Diametro Diameter	Lunghezza Length		€
103048	Ø 9	120 m	1	1045,35
103010	Ø 11	120 m	1	1101,55
103015	Ø 11	150 m	1	1266,80
103020	Ø 11	200 m	1	1636,15
103025	Ø 11	250 m	1	1934,20



Ricambi & accessori | Spare parts & accessories

Vergella completa di terminali filettati M12 colore nero

Wire rod complete with M12 threaded terminals black

Articolo Item	Diametro Diameter	Lunghezza Length		€
103072	Ø 9	60 m	1	369,45
103078	Ø 9	120 m	1	704,20
103080	Ø 11	120 m	1	773,75
103081	Ø 11	150 m	1	959,30
103086	Ø 11	200 m	1	1268,45
103091	Ø 11	250 m	1	1577,70

Accessori per sonde in fibra di vetro

Accessories for fiberglass fish tape



LYVIA



Congiuntore per riparazione

Joint for repair

Articolo Item	Descrizione Description		€
103203	∅ 9 mm	1	10,10
103205	∅ 11 mm	1	10,10



Giunto girevole
per accoppiamento di 2 sonde in acciaio
con filettature M12

Swivel joint
for connecting 2 steel fish tapes
with M12 thread

Articolo Item	Descrizione Description		€
102057	Giunto girevole Swivel joint	1	32,70



Terminale
con filetto M12

Terminal
with M12 thread

Articolo Item	Descrizione Description		€
103200	∅ 9 mm	1	10,10
103202	∅ 11 mm	1	10,10



Puntale
lunghezza 80 mm - ∅ 40 mm
con filetto M12

Tip
length 80 mm - ∅ 40 mm
with M12 thread

Articolo Item	Descrizione Description		€
103207	Puntale ∅ 40 mm Tip ∅ 40 mm	1	24,20



Puntale / tirante completo di grillo d'aggancio
abbinabile a tutte le calze con asola
con filetto M12

Tip/pulling loop complete with hooking shackle
to be combined with all grips with eyelet
with M12 thread

Articolo Item	Descrizione Description		€
103208	Puntale / tirante completo di grillo d'aggancio Tip / pulling loop complete with hooking shackle	1	28,25



Puntale con ruota di scorrimento per sonde
∅ 9 - ∅ 11
con filetto M12

Tip with sliding wheel for fish tape
∅ 9 - ∅ 11
with M12 thread

Articolo Item	Descrizione Description		€
103303	Puntale con ruota di scorrimento Tip with sliding wheel	1	36,35

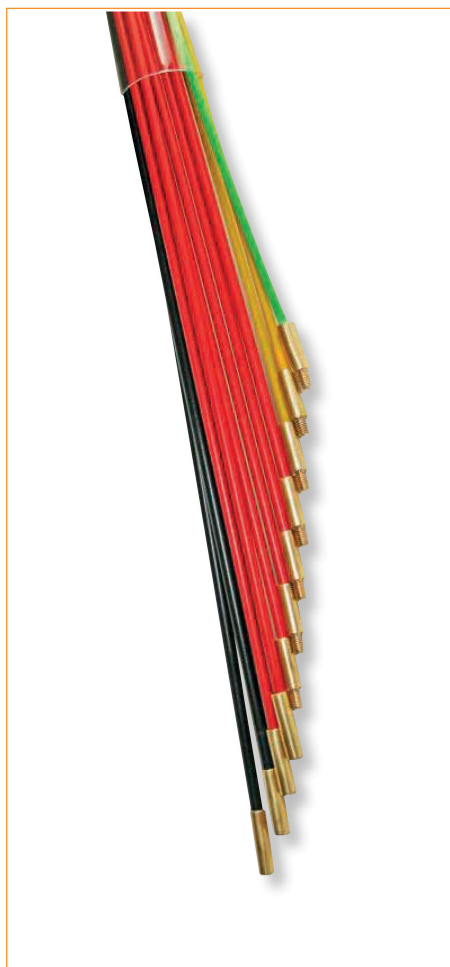

ASTE RIGIDE | STIFF RODS

IN FIBRA DI BASALTO

Per la posa dei cavi in controsoffitti, pavimenti flottanti, canalizzazioni.

L'anima in fibra di basalto conferisce resistenza alla flessione, il rivestimento in polipropilene diminuisce l'attrito.

Aste di differenti diametri e colori, ciascuna provvista di terminale in ottone filettato.

Il colore indica un differente raggio di curvatura.

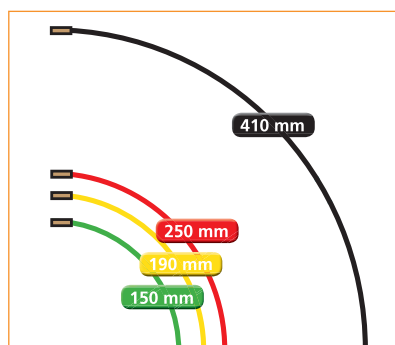

IN BASALT FIBER

For electrical installations in false ceiling, floating floors and track conditions.

Basalt fiber core guarantees high flexibility resistance, and polypropylene coating reduce friction.

Rods are with different diameters and colours, each is equipped with brass threaded terminal.

The colour indicates different bending radius.

RAGGIO DI CURVATURA

BENDING RADIUS

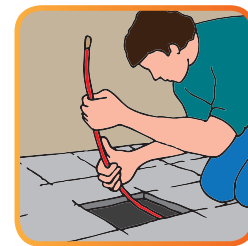
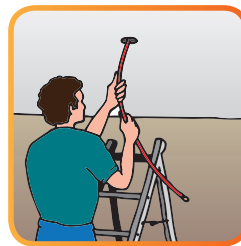
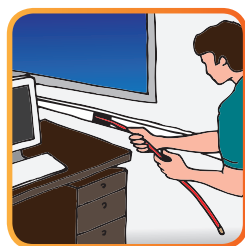

Articolo Item	Dimensioni Dimensions	Diametro Diameter	Colore Colour		€
N66100	Asta L=1M Rod L=1M	6,6 mm	nero black	3	15,70
R56100	Asta L=1M Rod L=1M	5,6 mm	rosso red	3	14,25
G46100	Asta L=1M Rod L=1M	4,6 mm	giallo yellow	3	13,25
V30100	Asta L=1M Rod L=1M	3,0 mm	verde green	3	11,50

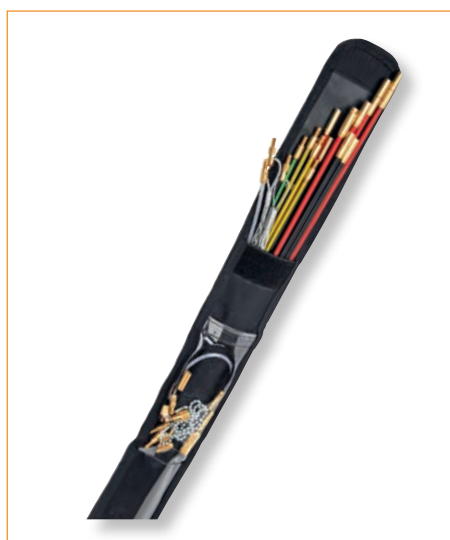

Set base | Basic Set

Il set viene fornito in una comoda faretra per agevolare l'utilizzo dei componenti.

Set base composto da:

2 pz. asta Ø 5,6mm L=1m, colore rosso (art. R56100)

3 pz. asta Ø 4,6mm L=1m, colore giallo (art. G46100)

1 pz. prolunga flessibile (art. N400)

1 pz. testa tonda (art. TT823)

1 pz. puntale con anello (art. OIAA16)

1 pz. calamita (art. PM14)

1 pz. catenella (art. CC4500)

To facilitate using of the components, it comes in a containing bag.

Basic set composed by:

2 pcs. rod Ø 5,6mm L=1m, red colour (item R56100)

3 pcs. rod Ø 4,6mm L=1m, yellow colour (item G46100)

1 pc. flexible extension rod (item N400)

1 pc. round starting head (item TT823)

1 pc. tip with ring (item OIAA16)

1 pc. magnet (item PM14)

1 pc. chain (item CC4500)

Articolo Item	Descrizione Description		€
SAS.5	Set aste di spinta L=5m Wire push pull rods L=5m set	1	108,00

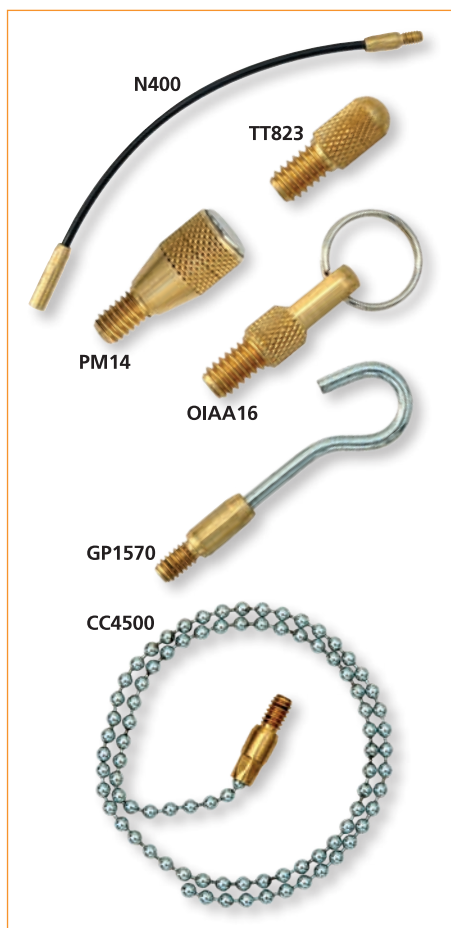

Accessori | Accessories

Grazie ai numerosi accessori, che si possono avvitare sulla sommità dell'ultima asta, è estremamente semplice il lavoro di introduzione della sonda, come pure di trazione dei cavi.

Thanks to many accessories, which can be screwed on the rods, it is very easy to introduce fish tape and pull cables.

Articolo Item	Descrizione Description	Diametro Diameter	Colore Colour		€
N400	Prolunga flessibile Flexible extention rod	4,0 mm	nero black	3	8,60
TT823	Testa tonda Round starting head		ottone brass	5	3,46
OIAA16	Puntale con anello Tip with ring		ottone brass	5	12,55
PM14	Calamita Magnet		ottone brass	3	12,45
CC4500	Catenella Chain		acciaio steel	1	11,25
GP1570	Gancio Hook		acciaio steel	5	12,10

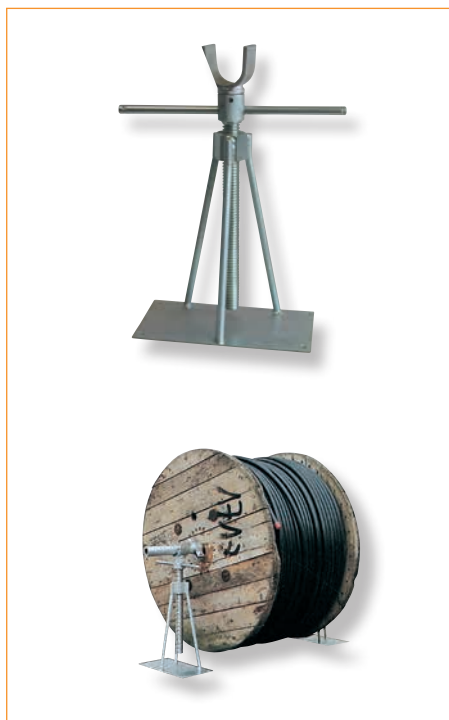

Cavalletto alza bobine meccanico a treppiede

In robusta struttura d'acciaio, finitura zincata.
Sollevamento tramite vite meccanica comandata da 1 manovella.
Regolabile da 54 a 100 cm
Adatto per il sollevamento di bobine da Ø 1200 a 2000 mm
Portata: 1600 kg con 2 cavalletti
Peso: 14 kg

ATTENZIONE: Codice e prezzo sono riferiti a singolo pezzo

Tripod mechanical cable drum lifter trestle

In sturdy steel structure, zinc plated finish.
Lifting by mechanical screw controlled by 1 crank handle.
Adjustable from 54 to 100 cm
Suitable for lifting reels from Ø 1200 to 2000 mm
Load: 1600 kg with 2 trestles
Weight: 14 kg

WARNING: Code and price refer to the individual piece

Articolo Item	Descrizione Description		€
107015	Cavalletto meccanico Mechanical trestle	2	353,00

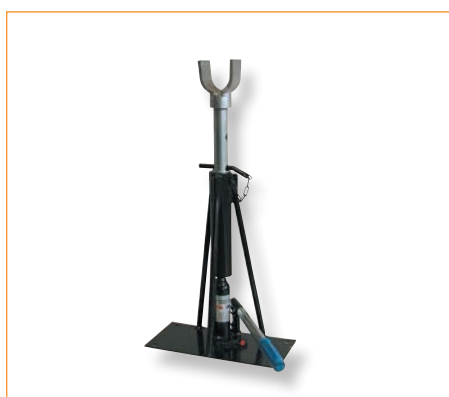

Cavalletto alzabobine idraulico

In robusta struttura di acciaio, finitura zincata.
Parte centrale mobile azionata da un martinetto idraulico.
Regolabile da 55 a 90 cm
Adatto per il sollevamento di bobine da Ø 1100 a 1700 mm
Portata: 1600 kg con 2 cavalletti
Peso: 17 kg

ATTENZIONE: Codice e prezzo sono riferiti a singolo pezzo

Hydraulic cable drum lifter trestle

In sturdy steel structure, zinc plated finish.
Mobile central part operated by a hydraulic jack.
Adjustable from 55 to 90 cm
Suitable for lifting reels from Ø 1100 to 1700 mm
Load: 1600 kg with 2 trestles
Weight: 17 kg

WARNING: Code and price refer to the individual piece

Articolo Item	Descrizione Description		€
107016	Cavalletto idraulico Hydraulic trestle	2	524,45

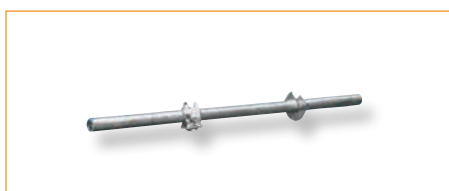

Albero di srotolamento ed accessori

Albero tubolare in lega leggera Ø 60 mm, lunghezza 1500 mm - con cuscinetti alle estremità

Unwinding shaft and accessories

Tubular shaft in light alloy Ø 60 mm, length 1500 mm - with bearings at the ends

Articolo Item	Descrizione Description		€
107025	Albero tubolare Tubular shaft	1	709,10
107026	Collare in acciaio zincato Ø 60 mm per bloccaggio bobina Zinc plated steel collar Ø 60 mm for reel locking	1	108,20
107027	Collare in acciaio zincato Ø 60 mm per centraggio bobina Zinc plated steel collar Ø 60 mm for reel centring	1	198,30



Pattino di srotolamento universale

Con rulli di scorrimento in acciaio imperniati su cuscinetti a sfere.

Rullo posteriore regolabile in 3 diverse posizioni.

Larghezza: 500 mm

Adatto per ruotare bobine da Ø 200 a 700 mm

Peso max bobina: 200 kg

Peso del pattino: 8,8 kg

Esecuzione: verniciata

Universal unwinding frame

With steel sliding rollers pivoting on ball bearings. Rear roller adjustable in 3 different positions.

Width: 500 mm

Suitable to rotate reels from Ø 200 a 700 mm

Max. reel weight: 200 kg

Frame weight: 8.8 kg

Finish: painted

Articolo Item	Descrizione Description		€
107020	Pattino universale Universal frame	1	334,80



Coppia di pattini di srotolamento

Permette di ruotare sul posto la bobina e svolgere i cavi velocemente.

Composto da un telaio d'acciaio con finitura zincata bianca con due rulli di scorrimento in alluminio imperniati su cuscinetti a sfere.

Uno dei due rulli è mobile e può essere spostato in 4 diverse posizioni, in relazione al diametro della bobina da svolgere.

Adatto per ruotare bobine

da Ø 400 a 1000 mm peso max: 600 kg

da Ø 1000 a 1200 mm peso max: 750 kg

Peso del pattino: 15 kg

Esecuzione: zincatura bianca

Pair of unwinding frames

It lets you turn the reel in place and quickly unwind the cables.

Consisting of a steel frame with white zinc plated finish with two sliding rollers in aluminium pivoting on ball bearings.

One of the two rollers is mobile and can be moved in 4 different positions, in relation to the diameter of the reel to be unwound.

Suitable for rotating reels

from Ø 400 to 1000 mm max. weight: 600 kg

from Ø 1000 to 1200 mm max. weight: 750 kg

Frame weight: 15 kg

Finish: white zinc plating

Articolo Item	Descrizione Description		€
107010	Set di 2 pattini e barra distanziatrice Set of 2 frames and spacer bar	1	867,40



Asta telescopica con rullo guidacavo

Adatta come guida cavo in camerette e in entrata nei pozzetti

Esecuzione: zincata

Telescopic rod with cable guide roller

Suitable as cable guide in manholes and on pit entry

Finish: zinc plating

Articolo Item	Descrizione Description		€
105003	Corsa dell'asta: 30 - 50 cm Rod stroke: 30 - 50 cm	1	637,70
105006	Corsa dell'asta: 50 - 80 cm Rod stroke: 50 - 80 cm	1	679,35



Rullo posacavo

Di forma concava in tubo di acciaio senza saldatura, scorre su cuscinetti a sfere di tipo stagno alla polvere, impernati su telaio in tubo zincato.

Esecuzione: zincata

Peso: 5 kg

Cable laying roller

Concave shaped steel tube with no welding, slides on dust-proof ball bearings, pivoting on galvanised tube frame.

Finish: zinc plating

Weight: 5 kg

Articolo Item	Descrizione Description		€
105060	Rullo posacavo Cable laying roller	1	58,55



Rullo pieno

Imperniato su supporto **girevole**, su base di appoggio angolare per l'impiego su bordi e spigoli di pozzetti o chiusini

Esecuzione: zincata

Full roller

Pivoting on **swivel** support, on angular supporting base for use on edges and rims of pits or manholes

Finish: zinc plating

Articolo Item	Descrizione Description		€
105070	Rullo pieno Full roller	1	175,65



Dispositivo guidacavo

Ideale per ottenere un'introduzione ad alto grado di scorrimento su tutti i lati del cavo, nei tubi in PVC, cemento o acciaio. I quattro rulli di scorrimento preservano il cavo da ogni eventuale danneggiamento.

Esecuzione: zincata

Cable guide device

Ideal for high sliding entry on all sides of the cable, in PVC, concrete or steel pipes. The four sliding rollers preserve the cable from any damage.

Finish: zinc plating

Articolo Item	Diametro Diameter		€
103318	60 mm	1	268,00
103319	80 mm	1	279,30
103320	100 mm	1	290,60

Calze per trazione e posa dei cavi

Cable pulling grips

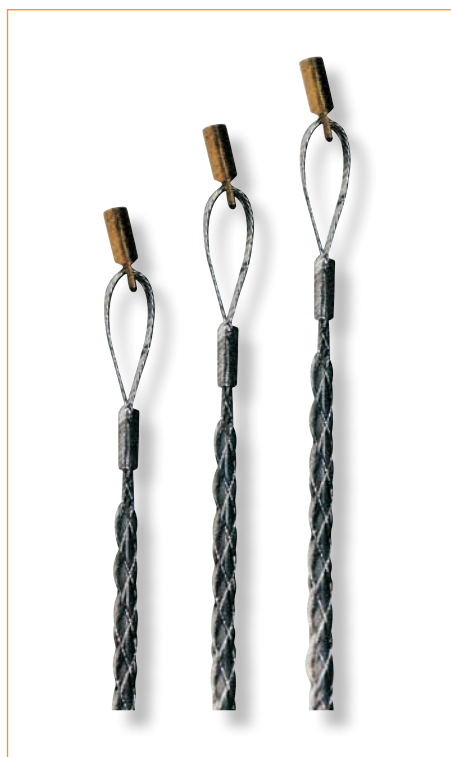

Le calze tiracavi sono realizzate a mano con fili in acciaio zincato, manicotto Talurit e tirante con filetto M5, resistenza filo 200 kg/mm²

The cable pulling grips are made by hand with galvanised steel wires, Talurit sleeve and pulling loop with M5 thread, wire resistance 200 kg/mm²

CALZE PER IMPIANTI CIVILI

Aperte a 1 estremità, complete di tirante ad occhiello M5, adatte ad essere montate su

LYVIABLITZ,

LYVIAMAX,

LYVIAFIL Ø 4 mm (con adattatore 060292)

CABLE PULLING GRIPS FOR CIVIL INSTALLATIONS

Open at 1 end, complete with M5 eyelet pulling loop, suitable for fitting on

LYVIABLITZ,

LYVIAMAX,

LYVIAFIL Ø 4 mm (with adapter 060292)

Articolo Item	Diametro cavi Cable diameter	Lunghezza Length	Carico rottura Tensile strength		€
* 108066	4-6 mm	220 mm	250 kp	1	17,00
* 108060	6-9 mm	250 mm	250 kp	1	18,15
108061	9-12 mm	350 mm	250 kp	1	22,65
108062	12-15 mm	450 mm	600 kp	1	26,40
108063	15-19 mm	500 mm	700 kp	1	43,40

senza tirante M5 | without M5 pulling loop

• 1 occhiello | • 1 eyelet

Articolo Item	Diametro cavi Cable diameter	Lunghezza Length	Carico rottura Tensile strength		€
108064	19-25 mm	520 mm	700 kp	1	47,20
108065	25-31 mm	580 mm	1800 kp	1	54,75

Calze per trazione e posa dei cavi

Cable pulling grips

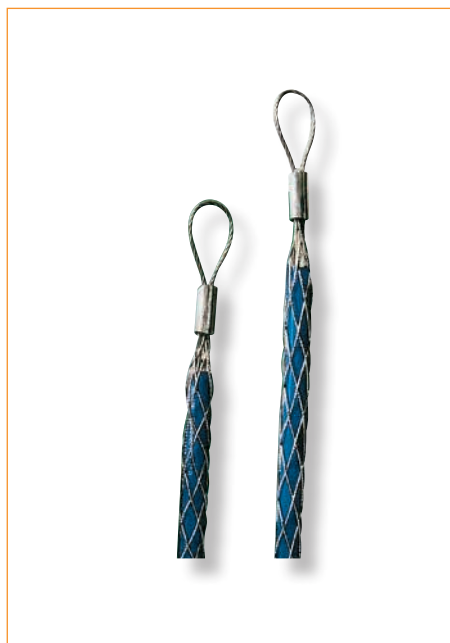

CALZE CON ASOLA PER INFILAGGIO IN CAVIDOTTI
• 1 occhiello

CABLE PULLING GRIPS WITH EYELET FOR DRAWING IN CONDUITS
• 1 eyelet

Articolo Item	Diametro cavi Cable diameter	Lunghezza Length	Carico rottura Tensile strength		€
108000	15-20 mm	1250 mm	3200 kp	1	58,50
108001	20-30 mm	1250 mm	3200 kp	1	66,05
108002	30-40 mm	1250 mm	3900 kp	1	81,15
108003	40-50 mm	1250 mm	3900 kp	1	94,35

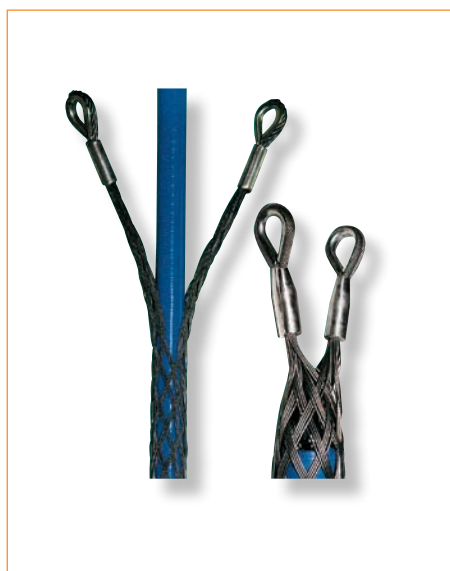

CALZE APERTE O AVVOLGENTI

Calze speciali aperte su tutta la lunghezza, con 2 occhielli.

Da usarsi per prese intermedie; la calza si avvolge attorno al cavo e si "cuce" con un filo in acciaio in dotazione.

OPEN OR ENVELOPING CABLE PULLING GRIPS

Special grips open along the entire length, with 2 eyelets.

To be used for intermediate grabs; the grip is wrapped around the cable and is "sewn" with the supplied steel wire.

Articolo Item	Diametro cavi Cable diameter	Lunghezza Length	Carico rottura Tensile strength		€
108040	15-20 mm	1250 mm	2600 kp	1	84,90
108041	20-30 mm	1250 mm	3200 kp	1	88,65
108042	30-40 mm	1250 mm	3900 kp	1	81,15
108045	60-70 mm	1500 mm	3900 kp	1	118,90



SPEEDLY

Grazie al lubrificante SPEEDLY la posa di cavi di qualsiasi dimensione in tubi corrugati ed in cunicoli sia di plastica che di cemento, può procedere con la massima speditezza e risparmio di fatica.

SPEEDLY non solo riesce ad eliminare il 70% dell'attrito ma non unge, non sporca e, una volta essiccato riveste il cavo, grazie alla propria composizione molecolare, con una pellicola protettiva rendendolo inattaccabile da agenti corrosivi e preservando dall'invecchiamento sia i cavi di plastica che quelli in gomma.

Thanks to the SPEEDLY lubricant, laying any size cables can proceed with the utmost speed and effortlessly in corrugated tubes and ducts, either in plastic or concrete.

SPEEDLY is able to remove 70% friction and also is oil-free, does not stain and after drying it coats the cable, thanks to its molecular composition, with a protective film thus preventing aggression from corrosive agents and preserving from ageing, both plastic and rubber cables.

Non forma muffe e non fermenta

It does not form mould and does not ferment

Innocuo per l'uomo e l'ambiente

Non-toxic for humans and environment

Articolo Item	Descrizione Description		€
60753	Flacone da lt. 0,5 - accessorato con pratico beccuccio salvagoccia <i>Bottle l. 0.5 - equipped with handy drip spout</i>	25	3,23
60750	Flacone da lt. 1 - accessorato con pratico beccuccio salvagoccia <i>Bottle l. 1 - equipped with handy drip spout</i>	15	5,75
60751	Fustino da lt. 5 <i>Drum l. 5</i>	1	26,50



SPEEDLY-S

Oltre alle caratteristiche dello SPEEDLY, ha un alto potere lubrificante (tre volte superiore allo Speedly). Resistente alle basse e alte temperature (-20°C +65°C).

In addition to SPEEDLY features, it has high lubricant power (three times higher than Speedly).

Resistant to low and high temperatures (-20°C +65°C).

Innocuo per l'uomo e l'ambiente

Non-toxic for humans and environment

Articolo Item	Descrizione Description		€
60755	Flacone da lt. 1 - accessorato con pratico beccuccio salvagoccia <i>Bottle l. 1 - equipped with handy drip spout</i>	15	6,60
60756	Fustino da lt. 5 <i>Drum l. 5</i>	1	29,00



SPEEDLY GEL

Gel lubrificante facilita la posa dei cavi elettrici, cavi telefonici, cavi in fibra ottica. Applicato durante la posa in canaline, tubi ricchi di curve, permette la posa di lunghe pezzature anche nelle condizioni più difficili. Riduce al minimo l'attrito e diminuisce la possibilità di danneggiamento dei cavi.

Evita il rovesciamento di liquido nell'ambiente.

Il Gel è incolore, non macchia, non lascia tracce indelebili.

Lubricating gel for easier installation of electrical cables, telephone cables, fibre optic cables. Applied during laying in conduits, pipes with many elbows, it makes it possible to lay long stretches even in the most difficult conditions. Reduces friction to the minimum and decreases the possibility of cable damage.

Prevents liquid spillage in the environment. The Gel is colourless, does not stain, does not leave indelible traces.

Innocuo per l'uomo e l'ambiente

Non-toxic for humans and environment

Articolo Item	Descrizione Description		€
60764	Tubo da 250 ml. 250 ml tube	12	3,00
60760	Flacone da Kg.1 - accessorato con pratico beccuccio salvagoccia Kg.1 Bottle - equipped with handy drip spout	15	6,84



SPEEDLY SPRAY

Innovativo prodotto per facilitare l'ingresso e lo scorrimento delle sonde e dei cavi nelle tubazioni.

Stessa formulazione del tradizionale ed apprezzato **SPEEDLY** in una nuova forma schiumogena.

La schiuma erogata all'interno delle tubazioni, viene spinta dal propellente anche nei tratti in salita, nelle curve e negli interstizi più nascosti, diminuendo così in maniera drastica i punti d'attrito.

Il cavo passando all'interno della schiuma viene interamente lubrificato aumentando la scorrevolezza e preservando dagli attriti il rivestimento esterno.

La schiuma spray è adatta per tubazioni con diametro massimo di 40 mm.

La nuova bomboletta da 400 ml è dotata del doppio sistema di spruzzo: diretto o tramite la cannucchia per facilitare l'introduzione della schiuma anche in presenza di curve e/o tubi di piccole dimensioni.

Innovative product for easier insertion and sliding of fish tape and cables in ducts.

*The same formula as the traditional and appreciated **SPEEDLY** in a new foaming form.*

The foam dispensed inside the ducts is pushed by the propellant also in rising sections, in curves and the most hidden gaps, thus drastically decreasing friction points.

When the cable runs through the foam it is entirely lubricated enhancing smooth laying and preserving the outer coating from friction.

The spray foam is suitable for pipes with maximum diameter 40 mm.

The new 400 ml spray can is fitted with double spraying system: direct or through the straw for easier insertion of the foam even in curves or small-sized pipes.

Innocuo per l'uomo e l'ambiente

Non-toxic for humans and environment

Articolo Item	Descrizione Description		€
60720	Confezionata in espositore da banco da 12 pz indivisibile Packaged in counter display in 12 pcs. unsplittable	12	6,70



WIRE PULLING

Grazie a questo liquido molto lubrificante e con forte azione detergente si possono sfilare con facilità i vecchi cavi installati.

Serve anche per facilitare l'introduzione e lo scorrimento dei cavi nuovi riducendo la tensione di tiro.

Innocuo per l'uomo e l'ambiente

Thanks to this highly lubricating liquid and with strong detergent action the old cables laid can be easily extracted.

It is also used for easier insertion and sliding of new cables reducing pull tension.

Non-toxic for humans and environment

Articolo Item	Descrizione Description		€
CDL.2	Flacone da lt. 1 - accessorato con pratico beccuccio salvagoccia <i>Bottle l. 1 - equipped with handy drip spout</i>	15	3,01
CDL.2.5	Fustino da lt. 5 <i>Drum l. 5</i>	1	14,75



Accessori | Accessories

Articolo Item	Descrizione Description		€
60758	Dispenser adatto per il flacone di Speedly Gel 60760 <i>Dispenser suitable for Speedly Gel 60760 bottle</i>	10	1,42
60757	Spruzzatore adatto per il flacone da lt. 1 di CDL.2 - 60750 - 60755 <i>Sprayer suitable for bottle l. 1 of CDL.2 - 60750 - 60755</i>	10	1,17



IDRO SPRAY Tracciante | *Tracing*

Pittura acrilica a base di acqua. Ideale per tracciare, marcare o delimitare spazi, aree su qualsiasi superficie. Di facile rimozione.

Water-based acrylic paint. Ideal to trace, mark or border spaces, areas on any surface. Easily removal.

PRODOTTO ECOLOGICO

ENVIRONMENTALLY-FRIENDLY PRODUCT

Innocuo per l'uomo e l'ambiente

Non-toxic for humans and environment

Articolo <i>Item</i>	Colore <i>Colour</i>	Capacità <i>Capacity</i>		€
60795.N	nero <i>black</i>	Aerosol da 400 ml. <i>Aerosol 400 ml.</i>	12	4,80
60795.B	blu <i>blue</i>	Aerosol da 400 ml. <i>Aerosol 400 ml.</i>	12	4,80
60795.R	rosso <i>red</i>	Aerosol da 400 ml. <i>Aerosol 400 ml.</i>	12	4,80



IDRO SPRAY Tracciante | *Tracing*

Espositore da banco completo con:

- 6 bombolette da 400 ml Idrospray colore nero
- 3 bombolette da 400 ml Idrospray colore blu
- 3 bombolette da 400 ml Idrospray colore rosso

Counter display complete with:

- 6 400 ml spray cans black Idrospray
- 3 400 ml spray cans blue Idrospray
- 3 400 ml spray cans red Idrospray

Articolo <i>Item</i>	Descrizione <i>Description</i>		€
60795.XP	Espositore da banco <i>Counter display</i>	1	56,80



PAINT AWAY

Gel sverniciante per mani sporche di vernici e inchiostri da stampa.

Paint away è un gel protettivo e sverniciante per la pelle, con capacità di sciogliere e rimuovere dalle mani vernici e inchiostri da stampa.

Paint remover gel for hands soiled with paints and printing ink.

Paint away is a protective and paint removing gel for the skin, with the ability to dissolve and remove paints and printing ink from your hands.

PRODOTTO ECOLOGICO

ENVIRONMENTALLY-FRIENDLY PRODUCT

Articolo <i>Item</i>	Descrizione <i>Description</i>		€
60850	Flacone da 200 ml. <i>200 ml. bottle</i>	12	9,88



CLINER SPRAY

Detergente per contatti elettrici ed elettronici
 Deterge i contatti elettrici senza lasciare residui, penetra anche in punti di difficile accesso. Rimuove istantaneamente olii, grassi, polvere, sporco ed ossidi dai contatti.

Innocuo per l'uomo e l'ambiente

Detergent for electrical and electronic contacts
 It cleans electrical contacts without leaving any residues, penetrates even points hard to access. Instantly removes oil, grease, dust, dirt and oxides from contacts.

Non-toxic for humans and environment

Articolo Item	Descrizione Description		€
60770	Aerosol da 250 ml. Aerosol 250 ml.	12	7,13



SBLOCK SPRAY

Sbloccante universale
 Libera le parti metalliche ossidate sciogliendo la ruggine. Consente di sbloccare viti, dadi, bulloni, serrature ecc.

Innocuo per l'uomo e l'ambiente

Universal releaser
 It frees oxidised metal parts by dissolving rust. It lets you release screws, nuts, bolts, locks etc.

Non-toxic for humans and environment

Articolo Item	Descrizione Description		€
60775	Aerosol da 150 ml. Aerosol 150 ml.	12	5,75



ZINCO SPRAY

Zincante a freddo, ideale come ritocco per parti zincate su cancellate, inferriate, telai e come protezione su parti saldate o lavorate. Resistente ai grassi ed olii. Asciuga rapidamente e si può utilizzare come fondo per qualsiasi tipo di vernice. L'azione antiossidante è garantita dallo zinco e da resine speciali che consentono un perfetto aggrappaggio al metallo.

Confezionato in espositore in cartone contenente 6 bombolette

Cold galvanizing, ideal as retouching for galvanized parts on railings, gratings, frames and as protection on welded or machined parts.

Resistant to grease and oils. It dries quickly and can be used as a base for any type of paint.

The antioxidant action is guaranteed by the zinc and special resins that allow a perfect adhesion on the metal.

Packaged in carton display containing 6 cans

Articolo Item	Descrizione Description		€
60792	Aerosol da 400 ml. Aerosol 400 ml.	6	6,12



SILICON SPRAY

Lubrifica, protegge, impermeabilizza i contatti elettrici contro la corrosione e la ruggine.

Lubricates, protects, waterproofs electrical contacts against corrosion and rust.

Innocuo per l'uomo e l'ambiente

Non-toxic for humans and environment

Articolo Item	Descrizione Description		€
60785	Aerosol da 150 ml. Aerosol 150 ml.	12	5,75



AIR SPRAY

Aria ecologica compressa. Consente di eliminare tutte le impurità nei punti più delicati e inaccessibili.

Compressed ecological air. It lets you remove all dirt in the most delicate and inaccessible points.

Innocuo per l'uomo e l'ambiente

Non-toxic for humans and environment

GAS ECOLOGICO NON INQUINANTE

NON POLLUTING ENVIRONMENTALLY FRIENDLY GAS

Articolo Item	Descrizione Description		€
60791	Aerosol da 400 ml. Aerosol 400 ml.	12	7,12



WASHUP

**INNOVATIVO
INNOVATIVE**

Gel lavamani senza acqua

Utilissimo in assenza di acqua, rimuove dalle mani lo sporco e l'unto pesante ed ostinato.

Water-less hand washing gel

Useful when there is no water, removes dirt and heavy and obstinate grease from your hands.

Nuovo formato tascabile!

Disponibile anche in comodi flaconcini confezionati in espositore da banco da 24 pz. pronto all'uso.

New pocket size!

Available also in handy small bottle, packaged in counter display in 24 pcs., ready for use.



Articolo Item	Descrizione Description		€
60800	Flacone da 250 ml. 250 ml. bottle	12	11,45
60801	Flacone da 80 ml. 80 ml. bottle	24	7,31



SUNNY

Detergente per pannelli fotovoltaici.

Sunny effettua contemporaneamente un'azione di pulizia, di sgrassaggio e produce una pellicola che assicura l'effetto antistatico e anti-pioggia, consentendo all'acqua di scivolare via facilmente. Il prodotto è atossico, non corrosivo né aggressivo. La resa è di 100÷160 m²/litro (in funzione dello stato del pannello).

Detergent for photovoltaic panels.

Sunny simultaneously performs a cleaning, degreasing action while producing a film that assures antistatic and rain-proof effect, allowing water to be washed off easily. The product is non-toxic, non corrosive or aggressive. Yield is 100÷160 m²/litre (according to panel condition).



Articolo Item	Descrizione Description		€
60860	Flacone da 750 ml dotato di spruzzatore 750 ml bottle with sprayer	12	8,67
60861	Tanica da 5 lt. con pratico beccuccio per facilitare lo sversamento 5 l canister with handy spout for easier pouring	1	36,45

Gelly



Si tratta di un gel ad alta viscosità che, per effetto della gravità, è in grado di occupare tutti gli spazi, le cavità, gli interstizi all'interno del contenitore in cui viene collocato.

È un prodotto pronto per l'uso, non appiccica, non unge, ed è trasparente ed inodore.

Grazie alla particolare formulazione, GELLY è inerte rispetto alle variazioni di calore, all'invecchiamento e può essere riutilizzato più volte. È autoagglomerante ed ha un notevole potere isolante.

- **Autolivellante**
occupa tutti gli spazi all'interno del contenitore
- **Autoagglomerante**
non necessita di essere amalgamato
- **Pronto per l'uso**
non necessita di miscelazione
- **Riutilizzabile**
non solidifica, non si degrada
- **Rimovibile**
in ogni momento, anche dopo anni
- **Atossico**
non è pericoloso per l'uomo, gli animali, l'ambiente
- **Dielettrico**
ottimo potere isolante: 15 kv
- **Trasparente**
consente di verificare in ogni momento lo stato delle connessioni
- **Non appiccica**
non rimane e non sporca le superfici

This is a high viscosity gel which, by effect of gravity, is able to take all spaces, hollows, gaps inside the container where it is placed.

It is a ready for use product, non stick, non oily, and is transparent and odourless.

Thanks to its special formula, GELLY is inert to temperature changes, to ageing and may be reused several times. It is self-agglomerating and has remarkable isolating power.

- **Self-levelling**
takes all spaces inside the container
- **Self-agglomerating**
does not need being amalgamated
- **Ready for use**
does not need mixing
- **Reusable**
does not solidify, does not decay
- **Removable**
at any time, even after years
- **Non-toxic**
it is not dangerous for humans, animals or the environment
- **Dielectric**
excellent insulating power: 15 kv
- **Transparent**
it lets you check the condition of connections at any time
- **Non stick**
it does not remain and does not soil surfaces

COME UTILIZZARE GELLY | HOW TO USE GELLY



1 Stendere una porzione di GELLY sul fondo della scatola.
Lay one portion of GELLY on the bottom of the box.



2 Effettuare il cablaggio elettrico.
Perform wiring.



3 Riempire bene la scatola con GELLY, evitando di lasciare spazi vuoti.
Fill well the box with Gelly, without leaving any empty spaces.



4 Chiudere il coperchio della scatola.
Close the box cover.

Con Gelly Squeeze potete realizzare le stesse operazioni soprascritte senza sporcare mani e/o attrezzi.
With Gelly Squeeze you can realise same operation as described above, without getting your hands and/or tools dirty.



Guarda il video tutorial!
Watch tutorial!

Articolo Item	Descrizione Description		€
60950	Barattolo da gr 500 500 gr can	4	19,70
60950.5	Fustino da 5 kg 5 kg drum	1	167,95
60951	Gelly Squeeze - tubo da 250 gr Gelly Squeeze - 250 gr tube	12	11,30

GellyBox

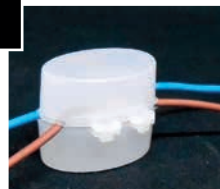
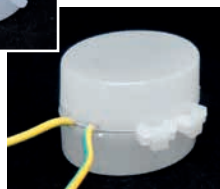

NEW

Pratiche scatolette per la protezione, l'isolamento e la messa in sicurezza delle connessioni elettriche. Costruite in polipropilene autoestinguente grado V0 e preriempite in entrambi i semigusci di gel isolante, già polimerizzato e pronto per l'uso. Ideali per piccole connessioni, siano esse terminali che passanti, effettuate con i più comuni morsetti per uso civile. Una volta richiusi i due semigusci, questo gel ad alta viscosità ed estremamente morbido si adatta perfettamente alle superfici presenti, riempiendo tutti gli interstizi.

Le scatolette sono provviste di sagome che possono essere sfondate all'occorrenza e facilitare il passaggio dei cavi.

- **Pronte per l'uso**
Già pre-riempite, utilizzo immediato
- **Alta protezione**
Grado IPX8
- **Facile utilizzo**
Riaccessibili in ogni momento senza bisogno di attrezzi
- **Per impianti domestici**
Max 3 conduttori sino a 2,5mm²
- **Sicure**
polipropilene grado V0, non contiene alogeni, resistente agli UV
Gel atossico, senza scadenza, riaccessibile
- Temperatura d'esercizio: 90°
- Temperatura d'installazione: -30° +50°C
- Per posa all'aperto: IPX8
- Approvate **CE**

Practical boxes for the protection, insulation and secure of electrical connections. Made in self-extinguishing polypropylene V0 grade and pre-filled in both half-shells of insulating gel, already polymerized and ready for use. Ideal for small connections, both terminal and through, made with the most common terminals for civil use. Once the two half-shells are closed, this highly viscous and extremely soft gel adapts perfectly to the surfaces present, filling all the interstices.

The boxes are provided with contours that can be broken down if necessary and facilitate the passage of the cables.

- **Ready to use**
Already pre-filled, immediate use
- **High protection**
rating IPX8
- **Easy to use**
Reachable at any time without the need of tools
- **For domestic installations**
Max 3 conductors up to 2.5mm²
- **Safe**
polypropylene grade V0, does not contain halogens, UV-resistant
Non-toxic gel, without expiration, re-accessible
- Working temperature: 90°
- Set up temperature: -30° +50°C
- For outdoor use: IPX8
- **CE** Approved

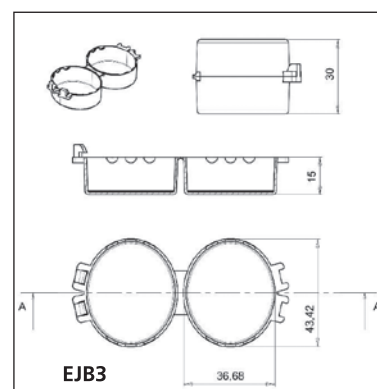
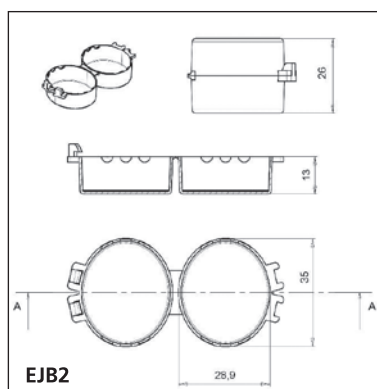

Articolo Item	Descrizione Description		€
EJB2	GELLY BOX piccolo per conduttori sino a Ø 1,5 mm ² Small GELLY BOX for wires up to Ø 1,5 mm ²	10	1,40
EJB3	GELLY BOX grande per conduttori sino a Ø 2,5 mm ² Big GELLY BOX for wires up to Ø 2,5 mm ²	5	2,45



FORBICI PER ELETTRICISTI
Standard

- lama cromata
- manici con isolamento in acetato
- lama diritta 143 mm

ELECTRICIAN'S SCISSORS
Standard

- chrome plated blade
- handles with acetate insulation
- 143 mm straight blade

Articolo Item	Descrizione Description		€
6015	Forbice con lame cromate Scissors with chrome plated blade	12	8,38



FORBICI PER ELETTRICISTI
Speciale

- lame in acciaio al carbonio brunito
- lama microdentata
- manici rivestiti in resina antiurto
- tipo dritto 143 mm

ELECTRICIAN'S SCISSORS
Special

- burnished carbon steel blades
- micro-serrated blade
- handles coated in shockproof resin
- 143 mm straight type

Articolo Item	Descrizione Description		€
6018	Forbice con lame in acciaio al carbonio brunito Scissors with burnished carbon steel blades	12	10,45



FORBICE EXTRAROBUSTA

- lame in acciaio inox microdentate
- manici in nylon
- impugnatura ergonomica antiscivolo
- lunghezza 140 mm

EXTRA-STURDY SCISSORS

- micro-serrated stainless steel blades
- nylon handles
- ergonomic non-slip handle
- length 140 mm

Articolo Item	Descrizione Description		€
259	Forbice con lame in acciaio inox Scissors with stainless steel blade	12	9,54



CESOIA UNIVERSALE

- adatta per tutti gli usi (tagliare filo metallico, cuoio, lamiera, ecc.)
- lama in acciaio inox finemente dentellata
- lunghezza 195 mm
- manici bicomponente isolati, in ABS con impugnatura antiscivolo
- con levetta di bloccaggio

UNIVERSAL SHEARS

- suitable for all uses (cutting metal wire, leather, sheet metal, etc.)
- finely serrated stainless steel blade
- length 195 mm
- insulated two-component handles, in ABS with non-slip grip
- with locking lever

Articolo Item	Descrizione Description		€
257	Cesoia con lame in acciaio inox Shears with stainless steel blade	12	16,25

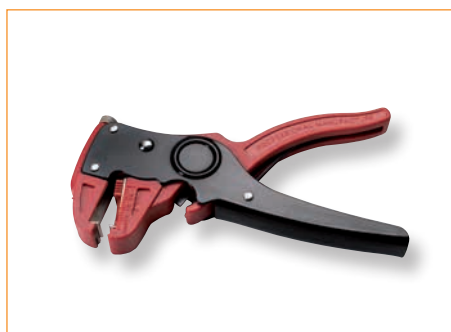

PINZA TRANCIA-SPELAFILI con regolazione automatica per l'incisione della guaina dei cavi da 0,2 a 6 mm² di sezione

- coltelli in acciaio temperato
- blocca, denuda, taglia cavi da Ø 0,5 a 8 mm²
- regolazione per variare la pressione delle lame per guaine esterne di cavi tripolari

WIRE CUTTER-STRIPPER PINCERS with automatic adjustment for cutting into the sheath of cables from 0.2 to 6 mm² section

- hardened steel blades
- blocks, strips, cuts cables from Ø 0.5 to 8 mm²
- adjustment to change blade pressure for external sheaths of three-pole cables

Articolo Item	Descrizione Description		€
* 78318	Pinza trancia-spelafili Wire cutter-stripper pincers	10	15,95

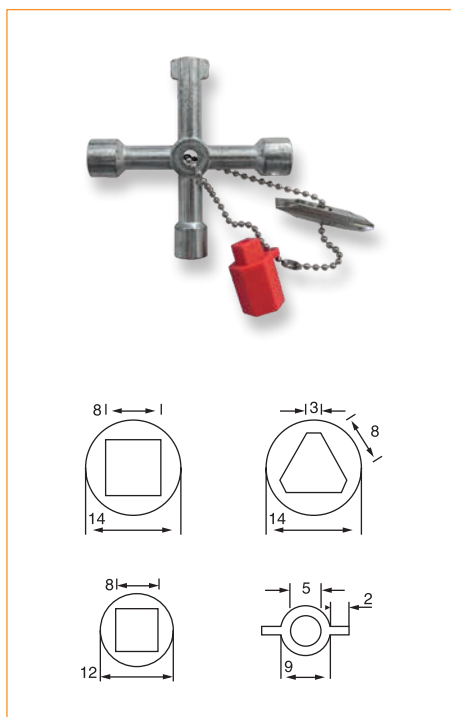

Chiave multiuso per quadri e armadi elettrici, gas, acqua

- in pressofusione di zinco
- dimensione croce: 71 mm
- con 4 diverse impronte + adattatore per punta cacciavite a taglio (7 mm) e croce (p h 2)
- confezione in blister

Multi-purpose wrench for switchboards and cabinets, gas, water

- in die-cast zinc
- cross size: 71 mm
- with 4 different shapes + adapter for slot (7 mm) and cross (p h 2) screwdriver tip
- blister package

Articolo Item	Descrizione Description		€
* CU.4	Chiave multiuso Multi-purpose wrench	12	6,73



CERCAFASE
a norme VDE 0680 e DIN 57680

- lama 65 x 3 mm
- clip di metallo

TESTER
compliant with standards VDE 0680 and DIN 57680

- 65 x 3 mm blade
- metal clip

Articolo Item	Lama Blade	Lunghezza Length		€
45200.GS	Ø 65 x 3 mm	140 mm	12	1,10
45700.GS	Ø 100 x 4 mm	190 mm	12	1,64



CERCAFASE
Tipo professionale

Costruito in materiale antiurto, ABS

- corpo unico non smontabile
- maggior luminosità dell'indicatore
- protezione delle dita
- costruito a norme europee EN
- adatto per tensioni da 125 a 250 V~



TESTER
Professional type

Constructed in shockproof material, ABS

- solid body that cannot be disassemble
- greater brightness indicator
- finger protection
- constructed to EN European standards
- suitable for voltage between 125 and 250 V~



Articolo Item	Lunghezza Length		€
45400	150 mm	12	1,73
45900	190 mm	12	2,21

Prodotti per incollare

Gluing products



PISTOLA TERMOADESIVA di grande capacità

Doppia funzione: ricaricabile o a tensione di rete.
 • Modalità wireless: per piccoli e brevi lavori
 • Modalità rete: per lavori di lunga durata
 Il supporto di appoggio è collegato alla rete e serve per ricaricare la pistola.

Nella confezione sono compresi 3 bastoncini di colla termofusibile.

Grilletto per avanzamento del bastoncino di colla (stick).

- Alimentazione: 240 V~ 50 Hz
- Potenza: 25 W
- Tempo di riscaldamento: 2 min
- Temperatura di esercizio: 180°

THERMOADHESIVE GUN Large capacity

Double function: rechargeable or with mains voltage.

- Wireless mode: for small and short jobs
- Mains mode: for long jobs

The support is connected to the mains and is used to charge the gun.

The package includes 3 hot melt glue sticks. Trigger for feeding the glue stick.

- Power supply: 240 V~ 50 Hz
- Power: 25 W
- Heating up time: 2 min
- Operating temperature: 180°

Articolo Item	Descrizione Description		€
GG.140	Pistola termoadesiva Thermoadhesive gun	6	17,55



BASTONCINI DI COLLA TERMOFUSIBILE

Ø 11,2 mm
 Lunghezza: 100 mm
 Trasparente
 La confezione comprende 6 bastoncini

HOT MELT GLUE STICKS

Ø 11,2 mm
 Length: 100 mm
 Transparent
 The package includes 6 sticks

Articolo Item	Descrizione Description		€
* 705.6	Bastoncini di colla termofusibile Hot melt glue sticks	1	1,97

Porta utensili

Tools sholder

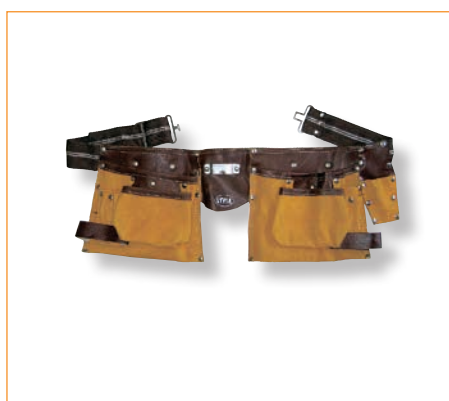

TASCHE PORTAUTENSILI A CINTURA

in pelle scamosciata
 • 14 posti per attrezzi vari
 • 220 x 600 mm
 • Cintura in tessuto robusto di polipropilene con fibbia regolabile

BELT TOOLS CARRIER

in suede leather
 • 14 pockets for various tools
 • 220 x 600 mm
 • Belt in sturdy polypropylene fabric with adjustable buckle

Articolo Item	Descrizione Description		€
170852	Tasche portautensili a cintura Tools carrier pockets belt	1	13,30



SALDATORE A STILO

Robusto, leggero per uso professionale e fai da te.
Doppio isolamento. □
Punta conica intercambiabile di lunga durata, in rame nichelato.
Alimentazione 220 V 50 Hz
Corredato di cavo e spina con terra centrale 10 A 250 V~ Ⓢ e di supporto in metallo.

Potenza: **15 W**
Punta fine Ø 3,5 mm adatta per la saldatura di circuiti di dimensioni ridotte
Tempo di riscaldamento: ca 180 sec.
Temperatura di punta: 360°C

Set composto da:

- saldatore
- dispenser con filo stagno Ø 1 mm, per uso hobbistico
- pasta salda
- supporto di metallo

SOLDERING IRON

Sturdy, light for professional and DIY use.
Double insulation.
Interchangeable, long lasting conical tip, in nickel-coated copper.
Power supply 220 V 50 Hz
Equipped with cable and plug with central earth 10 A 250 V~ Ⓢ and metal support.

Power: **15 W**
Fine tip Ø 3,5 mm suitable for soldering small-sized circuits
Heating time: 180 sec. approx.
Tip temperature: 360°C

Set consisting of:

- soldering iron
- dispenser with tin wire Ø 1 mm, for DIY use
- soldering paste
- metal support

Articolo Item	Descrizione Description		€
* 78015.KIT	Set saldatore a stilo Soldering iron set	1	13,00
* 0178015	Punta di ricambio Ø 3,5 mm conica (set di 3 pcs.) Spare tip Ø 3,5 mm conical (set of 3 pcs.)	1	1,68



SALDATORE A STILO

Robusto, leggero per uso professionale e fai da te.
Doppio isolamento.
Punta conica intercambiabile di lunga durata, in rame nichelato.
Alimentazione 220 V 50 Hz
Corredato di cavo e spina con terra centrale 10 A 250 V~ Ⓢ e di supporto in metallo.

Potenza: **40 W**
Punta Ø 5 mm adatta per normali saldature
Tempo di riscaldamento: ca 180 sec.
Temperatura di punta: 470°C

SOLDERING IRON SET

Sturdy, light for professional and DIY use.
Double insulation.
Interchangeable, long lasting conical tip, in nickel-coated copper.
Power supply 220 V 50 Hz
Equipped with cable and plug with central earth 10 A 250 V~ Ⓢ and metal support.

Power: **40 W**
Tip Ø 5 mm suitable for normal soldering
Heating time: 180 sec. approx.
Tip temperature: 470°C

Articolo Item	Descrizione Description		€
* 7840	Saldatore a stilo Soldering iron	10	8,29
* 017084	Punta di ricambio Ø 5 mm conica (set di 3 pz.) Spare tip Ø 5 mm conical (set of 3 pcs.)	1	2,72



Rocchetto di stagno da 500 gr Ø 1,22 mm circa.
 Lega di stagno (60 %) e piombo (40 %) con 3 anime
 di flussante (colofonia).
 Senza impiego di solventi.

500 gr spool of tin Ø 1,22 mm approx.
 Tin (60 %) and lead (40 %) alloy with 3 flux cores
 (rosin).
 With no use of solvents.

Per uso hobbistico

For DIY use

Articolo Item	Descrizione Description		€
BP.3011	Rocchetto stagno / piombo da 500 gr 500 gr spool of tin/lead	10	35,95



Rocchetto di stagno da 500 gr Ø 1,22 mm circa,
 conforme alla direttiva **RoHS**
 Lega di stagno (99,3 %) e rame (0,7 %).

500 gr spool of tin Ø 1,22 mm approx.,
 compliant with **RoHS** directive
 Tin (99.3 %) and copper (0.7 %) alloy.

Per uso professionale

For professional use

Articolo Item	Descrizione Description		€
BP.3011.LF	Rocchetto stagno / rame da 500 gr 500 gr spool of tin/copper	10	57,75



Lega di stagno (60 %) e piombo (40 %) con 3 anime
 di flussante (colofonia).
 Farfalla di stagno da 1 m.

Tin (60 %) and lead (40 %) alloy with 3 flux cores
 (rosin).
 1 m. tin card

Per uso hobbistico

For DIY use

Articolo Item	Descrizione Description		€
* BP.3010	Farfalla stagno/piombo da 1 m 1 m. tin/lead card	25	2,31



MULTIMETRO ANALOGICO

- Scale colorate
- Specchio antiparallasse
- Con fusibile di protezione
- Tensioni in continua: 2,5V - 10V - 50V - 250V - 500V
- Tensioni in alternata: 10V - 50V - 250V - 500V
- Correnti in continua: 500µA - 10mA - 250 mA
- Misura di resistenza(Ω): Ω x 10 - 1KΩ
- Prova batterie: 1,5V
- Alimentazione: 1 x AA (fornita in dotazione)
- Accessori: coppia puntali
- Dimensioni: 95 x 62 x 30 mm
- Peso: 100 gr

ANALOGUE MULTIMETER

- Colour scales
- Antiparallax mirror
- With protection fuse
- Voltages in DC: 2,5V - 10V - 50V - 250V - 500V
- Voltages in AC: 10V - 50V - 250V - 500V
- Currents in DC: 500µA - 10mA - 250 mA
- Resistance measurement (Ω): Ω x 10 - 1KΩ
- Battery test: 1.5V
- Power supply: 1 x AA (supplied)
- Accessories: pair of tips
- Dimensions: 95 x 62 x 30 mm
- Weight: 100 gr

Articolo Item	Descrizione Description		€
FT.7	Multimetro analogico <i>Analogue multimeter</i>	20	9,53
FT.7.CB	Multimetro analogico, imballo con borsa <i>Analogue multimeter, packing with case</i>	10	9,86



MULTIMETRO DIGITALE TASCABILE

- Dotato di custodia
- Display a cristalli liquidi
- Prova diodi
- Prova di continuità
- Tensioni in continua: 200 mV - 2V - 20V - 200V - 600V max
- Tensioni in alternata: 200V - 600V max
- Correnti in continua: 200 µA - 2000 µA - 20 mA - 200 mA
- Misure di resistenza(Ω): 200Ω - 2kΩ - 20kΩ - 200kΩ - 2MΩ - 20MΩ
- Protezione: contro i sovraccarichi con fusibile 0,2 A 250 V
- Alimentazione: 1 x CR2032 (in dotazione)
- Accessori: coppia puntali
- Dimensioni: 110 x 54 x 10 mm
- Peso: 55 gr

POCKET DIGITAL MULTIMETER

- Equipped with case
- Liquid crystal display
- Diode test
- Continuity test
- Voltages in DC: 200mV - 2V - 20V - 200V - 600V max
- Voltages in AC: 200V - 600V max
- Currents in DC: 200 µA - 2000 µA - 20 mA - 200 mA
- Resistance measurements (Ω): 200Ω - 2kΩ - 20kΩ - 200kΩ - 2MΩ - 20MΩ
- Protection: against overloads with fuse 0.2 A 250 V
- Power supply: 1 x CR2032 (supplied)
- Accessories: pair of tips
- Dimensions: 110 x 54 x 10 mm
- Weight: 55 gr

Articolo Item	Descrizione Description		€
FT.3001	Multimetro digitale tascabile <i>Pocket digital multimeter</i>	10	20,85



PORTATA FINO A 10 A

MULTIMETRO DIGITALE

- Completo di custodia antiurto
- Display a cristalli liquidi cifre 3½ digit, lettura max 1999
 - Prova diodi
 - Prova transistor
 - Prova di continuità
 - Tensioni in continua: 200 mV - 2V - 20V - 200V - 600V
 - Tensioni in alternata: 200V - 600V max
 - Correnti in continua: 200 µA - 2 mA - 20 mA - 200 mA - 10 A
 - Misure di resistenza(Ω): 200 Ω - 2 KΩ - 20 KΩ - 200 KΩ - 2 MΩ
 - Misure di temperatura: 40÷150 °C, 150÷1370 °C
 - Protezione: contro sovraccarichi con fusibile 200 mA 250V
 - Alimentazione: batteria zinco-carbone 9V in dotazione
 - Accessori: coppia puntali
 - Dimensioni: 138 x 69 x 31 mm
 - Peso: 200 gr

DIGITAL MULTIMETER

- Complete with shockproof case
- Liquid crystal display 3½ digits, max 1999 reading
 - Diode test
 - Transistor test
 - Continuity test
 - Voltages in DC: 200 mV - 2V - 20V - 200V - 600V
 - Voltages in AC: 200V - 600V max
 - Currents in DC: 200 µA - 2 mA - 20 mA - 200 mA - 10 A
 - Resistance measurements(Ω): 200 Ω - 2 KΩ - 20 KΩ - 200 KΩ - 2 MΩ
 - Temperature measurements: 40÷150 °C, 150÷1370 °C
 - Protection: against overloads with fuse 200 mA 250V
 - Power supply: zinc-carbon 9 V battery supplied
 - Accessories: pair of tips
 - Dimensions: 138 x 69 x 31 mm
 - Weight: 200 gr

Articolo Item	Descrizione Description		€
* FT.8300	Multimetro digitale <i>Digital multimeter</i>	10	15,30
* FT.8300.CB	Multimetro digitale, imballo con borsa <i>Digital multimeter, packing with case</i>	10	18,60
ST.8300	Puntali di ricambio <i>Spare tips</i>	1	1,40

RILEVATORI E DOMOTICA *DETECTORS AND DOMOTICS*



LYVIADECT

RILEVAMENTO 180°

180° DETECTION

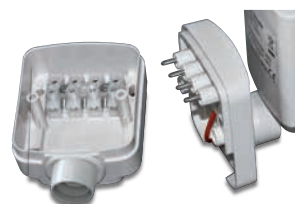

La gamma di rilevatori di presenza ad infrarossi passivi LYVIADECT è stata equipaggiata con gli ultimi ritrovati della tecnologia:

- Ampio angolo di rilevamento: 180°
- Lente Fresnel ad alta sensibilità
- Doppio snodo che consente un'ampia libertà di regolazione
- Circuito con tecnologia zero-crossing per allungare la vita media delle lampade collegate
- Morsettiera di collegamento a pettine, per agevolare l'installazione
- Accessorio per innesto tubo rigido Ø 16 mm e Ø 20 mm
- Adatto per interno ed esterno

The LYVIADECT range of passive infrared motion detectors has been equipped with the latest technological developments:

- Wide detection angle: 180°
- High sensitivity Fresnel lens
- Double joint for wide free-adjustment
- Circuit with zero-crossing technology to extend the average life of connected lamps
- Comb connection terminal block to facilitate the installation
- Accessory for introduction in stiff tube Ø 16 mm and Ø 20 mm
- Suitable for indoor and outdoor

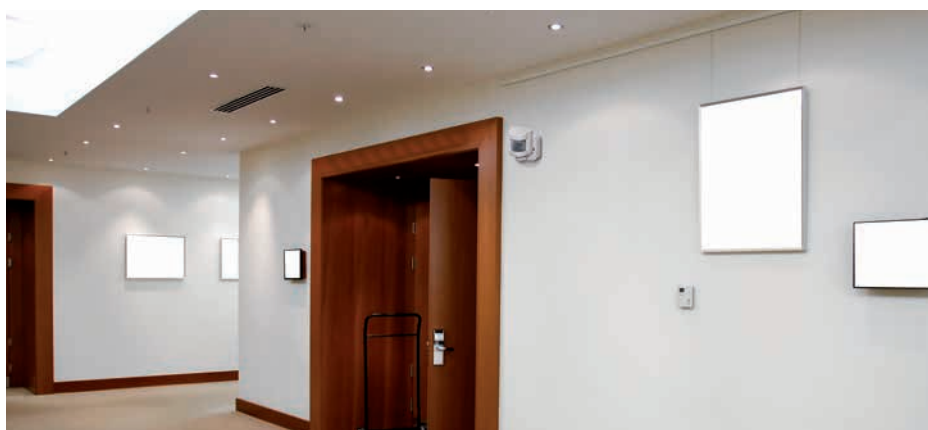

Supporto a muro con ampio vano per collegamento elettrico e morsettiera con innesto a pettine. Installazione più semplice e veloce. Corredato di accessorio per innesto tubo rigido Ø 16 mm e Ø 20 mm e foro sfondabile.

Wall support with wide compartment for electrical connection and comb connection terminal block. Easier and quicker installation. Equipped with accessory for introduction in stiff tube Ø 16 mm and Ø 20 mm and knock-out hole.



Guarda il video tutorial!

Watch tutorial!

LYVIADECT



180°

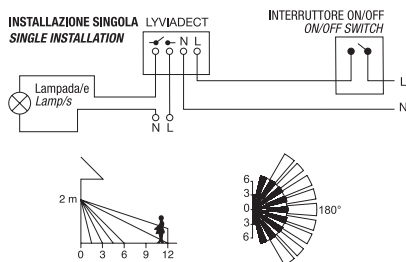

Caratteristiche tecniche:

- Alimentazione: 220 - 240 V~ 50 Hz
- Carico: 1800 W per lampade ad incandescenza
1000 VA per lampade fluorescenti
450 W per lampade Led
- Carico minimo: 8 W
- Angolo di rilevamento: **180°**
- Portata del fascio: **12 m (max)**
- Temporizzatore: **da 3 sec. a 20 min.**
- Crepuscolare: da 5 a 1000 Lux
- Grado di protezione: **IP 55**
- Dotato di tecnologia zero-crossing
- Colore: bianco ghiaccio

Technical features:

- Power supply: 220 - 240 V~ 50 Hz
- Load: 1800 W for incandescence lamps
1000 VA for fluorescent lamps
450 W for LED lamps
- Minimum load: 8 W
- Detection angle: **180°**
- Beam range: **12 m (max)**
- Timer: **from 3 sec. to 20 min.**
- Twilight: from 5 to 1000 Lux
- Protection degree: **IP 55**
- Fitted with zero-crossing technology
- Colour: polar white

Apparecchio dotato di lente Fresnel ad alta sensibilità, e di supporto a snodo, regolabile esternamente nelle diverse direzioni, adatto per interno ed esterno.

Appliance fitted with high sensitivity Fresnel lens and joint support, adjustable externally in the various directions, suitable for indoor and outdoor.

Con funzione di test, per poter orientare meglio la direzione dell'apparecchio.

With test function for best adjusting the appliance's direction.

Articolo Item	Angolo di rilev. Det. angle	Portata fascio Beam range	Grado di prot. Protect. degree		€
* 58575	180°	12 m (max)	IP 55	12/48	24,45

180°

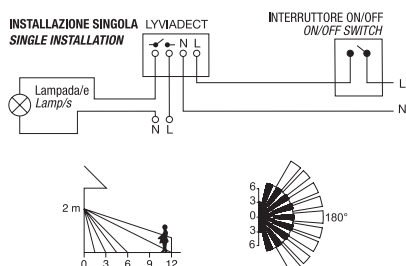

LYVIADECT RELÈ

Con contatto "pulito"
With "free" contact



Consente l'attivazione di un carico funzionante ad una tensione diversa da 230 V senza l'ausilio di relè esterni all'apparecchiatura.

To activate a load operating at a voltage different than 230 V with no relays outside the appliance.

Caratteristiche tecniche:

- Alimentazione: 220 - 240 V~ 50 Hz
- Carico: max 8A a 230V (cosφ = 1)
Uscita con contatto normalmente aperto N.A. non in tensione
- Angolo di rilevamento: **180°**
- Portata del fascio: **12 m (max)**
- Temporizzatore: **da 3 sec. a 20 min.**
- Crepuscolare: da 5 a 1000 Lux
- Grado di protezione: **IP 55**
- Dotato di tecnologia zero-crossing
- Colore: bianco ghiaccio

Technical features:

- Power supply: 220 - 240 V~ 50 Hz
- Load: max 8A a 230V (cosφ = 1)
Output with contact normally open N.O. no voltage
- Detection angle: **180°**
- Beam range: **12 m (max)**
- Timer: **from 3 sec. to 20 min.**
- Twilight: from 5 to 1000 Lux
- Protection degree: **IP 55**
- Fitted with zero-crossing technology
- Colour: polar white

Apparecchio dotato di lente Fresnel ad alta sensibilità, e di supporto a snodo, regolabile esternamente nelle diverse direzioni, adatto per interno ed esterno.

Appliance fitted with high sensitivity Fresnel lens and joint support, adjustable externally in the various directions, suitable for indoor and outdoor.

Con funzione di test, per poter orientare meglio la direzione dell'apparecchio.

With test function for best adjusting the appliance's direction.

Articolo Item	Angolo di rilev. Det. angle	Portata fascio Beam range	Grado di prot. Protect. degree		€
* 58500	180°	12 m (max)	IP 55	12/48	24,45



GRAND'ANGOLO



Trova applicazione sia all'interno che all'esterno.
Testa sferica regolabile sia orizzontalmente che verticalmente.

Caratteristiche tecniche:

- Alimentazione: 220 - 240 V~ 50 Hz
- Carico: 1000 W per lampade ad incandescenza
400 VA per lampade fluorescenti
200 W per lampade led
- Angolo di rilevamento: **180°**
- Portata del fascio: **12 m (max)**
- Temporizzatore: **da 5 sec. a 12 min.**
- Crepuscolare: da 0 a 1000 Lux
- Grado di protezione: **IP 44**
- Colore: bianco ghiaccio

*Applied both indoor and outdoor.
Horizontally and vertically adjustable round head.*

Technical features:

- Power supply: 220 - 240 V~ 50 Hz
- Load: 1000 W for incandescence lamps
400 VA for fluorescent lamps
200 W for LED lamps
- Detection angle: **180°**
- Beam range: **12 m (max)**
- Timer: **from 5 sec. to 12 min.**
- Twilight: from 0 to 1000 Lux
- Protection degree: **IP 44**
- Colour: polar white

Articolo Item	Angolo di rilev. Det. angle	Portata fascio Beam range	Grado di prot. Protect. degree		€
* 58534	180°	12 m (max)	IP 44	10/20	24,45



DOPPIA OTTICA



Trova applicazione sia all'interno (corridoi - scale - toilette - cantine - box), che all'esterno (IP 45).

Con la lente DOME si ottiene un angolo di rilevamento di 240° e si ha la protezione contro la penetrazione a carponi (effetto tenda) ed una distanza di rilevamento di circa 12 metri.

Inoltre applicando le mascherine si può diminuire il campo di rilevamento.

Viene dato in dotazione un supporto per le installazioni su angoli esterni o interni.

Applied both indoor (corridors - stairs - toilets - cellars - boxes), and outdoor (IP 45).

With the DOME lens is obtained 240° detection angle, achieving protection against crawling penetration (curtain effect) and detection distance of about 12 meters.

Furthermore the detection range can be decreased by applying the covers.

It is equipped with a support for installation on outer or inner angles.

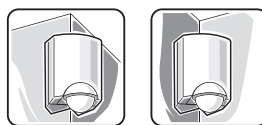

Caratteristiche tecniche:

- Alimentazione: 230 - 240 V~ 50 Hz
- Carico: 2000 W per lampade ad incandescenza
1000 W per lampade alogene
300 W per lampade fluorescenti
200 W per lampade led
- Angolo di rilevamento: **240°**
- Portata del fascio: **da 6 a 12 m**
- Temporizzatore: **da 10 sec. a 10 min.**
- Crepuscolare: da 5 a 2000 Lux
- Grado di protezione: **IP 45**
- LED per controllare il rilevamento
- Dimensioni (a x l x p): 125 x 75 x 35 (60) mm
- Dotato di tecnologia zero-crossing
- Colore: bianco ghiaccio

Technical features:

- Power supply: 230 - 240 V~ 50 Hz
- Load: 2000 W for incandescence lamps
1000 W halogen lamps
300 W for fluorescent lamps
200 W for LED lamps
- Detection angle: **240°**
- Beam range: **from 6 to 12 m**
- Timer: **from 10 sec. to 10 min.**
- Twilight: from 5 to 2000 Lux
- Protection degree: **IP 45**
- LED to check detection
- Dimensions (h x l x d): 125 x 75 x 35 (60) mm
- Fitted with zero-crossing technology
- Colour: polar white

Articolo Item	Angolo di rilev. Det. angle	Portata fascio Beam range	Grado di prot. Protect. degree		€
SL.300	240°	12 m (max)	IP 45	6/48	32,35

Mini allarme e segnapasso a batteria

Battery operated mini alarm and steplight

LYVIA

CE

3 in 1
Campanello
allarme
segnapasso

3 in 1
Steplight
alarm
chime

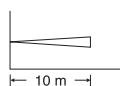

OCCHIO VIGILE

Modello brevettato

Allarme portatile a batteria. Dotato di rilevatore di presenza e di 2 melodie selezionabili; è in grado di rilevare e segnalare la presenza di persone nell'area controllata. Adatto per le installazioni a parete, a soffitto, sopra le porte grazie alla staffa mobile. Inoltre può funzionare anche come campanello per porta, utilizzando l'apposito cavetto in dotazione.

Caratteristiche tecniche

- Alimentazione: batteria alcalina 9 V; (non fornita) con possibilità di collegamento ad alimentatore 9 V - 300 mA
- Intensità sonora: 100 dB a 1 m
- Angolo di rilevamento: **130°**
- Portata del fascio: **10 m**
- Durata allarme: 4 sec. in posizione 30 sec. in posizione allarme
- Consumo: 0,5 mA in stand-by
- Dimensioni: 76 x 32 x 48 mm
- Colore: bianco ghiaccio

Patented model

Portable battery operated alarm. Equipped with motion detector and 2 selectable melodies; it is able to detect and signal people's presence in the monitored area. Suitable for installation on wall, ceiling, above doors thanks to the mobile bracket. It may also be used as door bell, using the suitable cable supplied.

Technical features

- Power supply: alkaline 9 V battery; (not supplied) with possibility to connect to 9 V - 300 mA driver
- Sound intensity: 100 dB at 1 m
- Detection angle: **130°**
- Beam range: **10 m**
- Alarm duration: 4 sec. in position 30 sec. in alarm position
- Consumption: 0.5 mA in stand-by
- Dimensions: 76 x 32 x 48 mm
- Colour: polar white

Articolo Item	Angolo di rilev. Det. angle	Portata fascio Beam range	Grado di prot. Protect. degree		€
* 58600	130°	10 m (max)	IP 20	16/32	21,40

Mini lampada portatile led a batteria

Battery operated mini portable LED lamp

bubble

CE

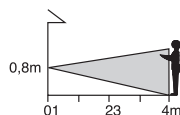
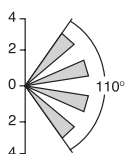

MINI LAMPADA PORTATILE LED con rilevatore di presenza funziona a batteria

Ideale come segnapasso per illuminare in maniera automatica i luoghi ove non vi è energia elettrica.

- Orientabile: a 360°
- Portatile: il corpo può essere rimosso dal guscio e diventare una pratica torcia
- Alimentazione: 4 batterie ministilo (AAA), non incluse
- 5 led bianco caldo (2700°K) ad altissima luminosità
- Angolo di rilevamento: **110°**
- Crepuscolare: 5 Lux
- Rilevatore di presenza: con portata raggio **4 m**
- Selettore per temporizzare intervento: OFF - 10 sec. - 20 sec.
- Dimensioni: Ø75 mm

MINI PORTABLE LED LAMP with motion detector, battery operated

Ideal as step light to automatically light places where there is no electric energy.

- Adjustable: at 360°
- Portable: the body may be removed from the shell and turns into a handy torch
- Power supply: 4 batteries R03 (AAA), not included
- 5 warm white LEDs (2700°K) extremely bright
- Detection angle: **110°**
- Twilight: 5 Lux
- Motion detector: with beam range **4 m**
- Selector for timing operation: OFF - 10 sec. - 20 sec.
- Dimensions: Ø75 mm

Articolo Item	Angolo di rilev. Det. angle	Portata fascio Beam range	Colore Colour		€
3005.N	110°	4 m	nero black	8	12,45
3005.V	110°	4 m	verde green	8	12,45
3005.A	110°	4 m	arancione orange	8	12,45

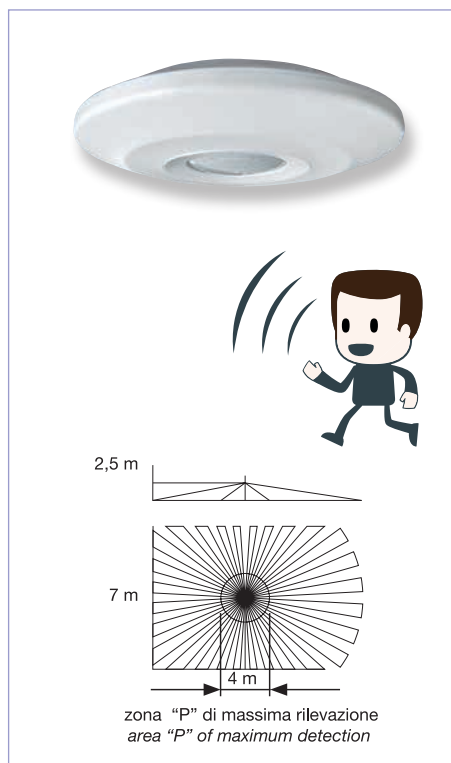

VOICEDECT^{360°}



- Rilevatore di movimento, presenza e voce, è in grado di rilevare il rumore dell'ambiente, mantenendo acceso il carico collegato
- Per montaggio a soffitto, sia per installazioni civili che nel terziario.
- Nuovo design e dimensioni ridotte.
- Rileva anche piccoli movimenti (nella zona "P")
- Regolazioni direttamente sull'apparecchio
- Dotato di funzione "pulse": alla rilevazione viene inviato un impulso della durata di 0,5 sec.

Caratteristiche tecniche:

- Alimentazione: 220 - 240 V~ 50 Hz
- Carico: 1000 W per lampade ad incandescenza
500 VA per lampade fluorescenti
500 VA per lampade a risparmio
250 W per lampade led
- Angolo di rilevamento: **360°**
- Portata del fascio: Ø **7 m** ad altezza 2,5m
- Zona "P": 4 m dal centro
- Rilevamento sonoro: 45 dB~ 70dB
- Temporizzatore: **da 30 sec. a 20 min.**
- Crepuscolare: da 5 a 1000 Lux
- Grado di protezione: **IP 20 - solo per interno**
- Dimensioni: Ø 120 mm, spessore 26 mm
- Dotato di tecnologia zero-crossing
- Colore: bianco ghiaccio

- *Motion, presence and voice detector, it is able to detect ambient noise, keeping the connected load switched on*
- *For ceiling mounting, both for residential installation and in the service industry.*
- *New design and compact size.*
- *It detects even small movements (in area "P")*
- *Adjustments directly on the appliance*
- *Equipped with "pulse" function: upon detection a pulse lasting 0,5 sec. is sent.*

Technical features:

- Power supply: 220 - 240 V~ 50 Hz
- Load: 1000 W for incandescence lamps
500 VA for fluorescent lamps
500 VA for energy saving lamps
250 W for LED lamps
- Detection angle: **360°**
- Beam range: Ø **7 m** at height 2.5 m
- Area "P": 4 m from centre
- Sound detection: 45 dB~ 70dB
- Timer: **from 30 sec. to 20 min.**
- Twilight: from 5 to 1000 Lux
- Protection degree: **IP 20 - for indoor only**
- Dimensions: Ø 120 mm, thickness 26 mm
- Fitted with zero-crossing technology
- Colour: polar white

Articolo Item	Angolo di rilev. Det. angle	Portata fascio Beam range	Grado di prot. Protect. degree		€
58380	360°	Ø 7 m (max)	IP 20	6/24	38,80

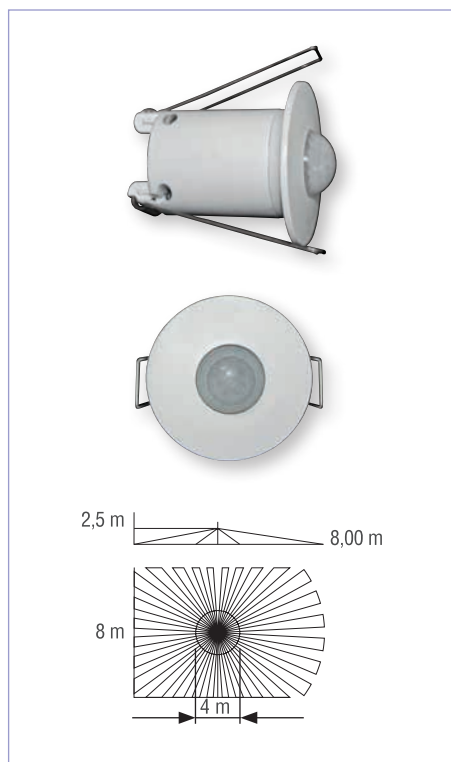

MINIDECT^{360°}



RILEVATORE DI MOVIMENTO E PRESENZA INSTALLAZIONE DA INCASSO

- Unità di rilevazione dalle dimensioni ridotte
- Rileva anche piccoli movimenti (nella zona "P")
- Regolazioni direttamente sull'apparecchio

Caratteristiche tecniche:

- Alimentazione: 220 - 240 V~ 50 Hz
- Carico: 2000 W per lampade ad incandescenza
1000 W per lampade alogene
500 VA per lampade fluorescenti
500 VA per lampade elettroniche
250 W per lampade led
- Angolo di rilevamento: **360°**
- Portata del fascio: Ø **8 m** ad altezza 2,5 m
- Zona "P": 4 m dal centro
- Temporizzatore: **da 30 sec. a 30 min.**
- Crepuscolare: da 5 a 1000 Lux
- Grado di protezione: **IP 20 - solo per interno**
- Dimensioni Ø foro nel controsoffitto: 38 mm
- Fissaggio: a mollette
- Funzione pulse: impulso per 0,5 sec.
- Dimensioni rilevatore: Ø 52 x 67 mm
- Dimensioni unità di potenza: 131 x 28 x 27 mm
- Colore: bianco ghiaccio

MOTION AND PRESENCE DETECTOR FOR RECESSED INSTALLATION

- Compact-sized detection unit
- It detects even small movements (in area "P")
- Settings directly on the appliance

Technical features:

- Power supply: 220 - 240 V~ 50 Hz
- Load: 2000 W for incandescence lamps
1000 W for halogen lamps
500 VA for fluorescent lamps
500 VA for electronic lamps
250 W for LED lamps
- Detection angle: **360°**
- Beam range: Ø **8 m** at height 2.5 m
- Area "P": 4 m from centre
- Timer: **from 30 sec. to 30 min.**
- Twilight: from 5 to 1000 Lux
- Protection degree: **IP 20 - for indoor only**
- Dimensions Ø hole in false ceiling: 38 mm
- Fixing: with clips
- Pulse function: 0.5 sec. pulse.
- Detector dimensions: Ø 52 x 67 mm
- Power unit dimensions: 131 x 28 x 27 mm
- Colour: polar white

Articolo Item	Angolo di rilev. Det. angle	Portata fascio Beam range	Grado di prot. Protect. degree		€
58121	360°	Ø 8 m (max)	IP 20	12/48	31,95

Finta telecamera

Dummy camera

LYVIA



Finta telecamera

Un LED rosso intermittente alimentato con batteria 9 V (inclusa) simula che la "finta telecamera" è in funzione.

- Corpo in metallo anodizzato
- Staffa regolabile

Dummy camera

An intermittent red LED powered by 9 V battery (included) simulates the "fake video camera" to be operating.

- Metal anodised body
- Adjustable bracket

Articolo Item	Angolo di rilev. Det. angle	Portata fascio Beam range	Grado di prot. Protect. degree		€
CP.63	-	-	IP 55	1/6	29,30

Rilevatori di movimento ad alta frequenza

High frequency motion detectors

CE  R&TTE

RILEVATORE
Alta frequenza

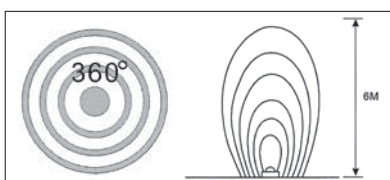

Questo tipo di tecnologia consente rilevazioni più precise, non soggette alle variazioni di temperatura dell'ambiente esterno, né alla direzione da cui proviene il movimento. Inoltre le onde elettromagnetiche possono superare senza problemi vetri, porte, controsoffittature e pareti sottili, con evidenti vantaggi dal punto di vista estetico e di sicurezza.

Caratteristiche tecniche:

- Alimentazione: 230V c.a.
- Tecnologia: alta frequenza a 5.8 Ghz
- Segnale in uscita: < 5 mW
- Carico: 1000W per lampade incandescenti
500VA per lampade fluorescenti
- Angolo di rilevamento: **360° verticale**
100° orizzontale
- Portata del fascio: **da 0,5 a 6 m** in modo continuo
- Crepuscolare: da 0,5 a 2.000 lux
- Temporizzatore: **da 3 sec. a 30 min.**
- Comando manuale (tramite interruttore esterno): commutabile per un massimo di 4 ore
- Grado di protezione: **IP 20 per uso all'interno**
- Completo di supporto per montaggio ad angolo (interno ed esterno) e per ingresso canalina
- Dimensioni: 113 x 75 x 34 mm
- Colore: bianco ghiaccio

This type of technology assures more precise detection, not subject to temperature changes in the external environment, nor to direction the motion comes from. Furthermore, the electromagnetic waves can go through glazing, doors, false ceilings and thin walls without any problems, with obvious aesthetic and safety advantages.

Technical features:

- Power supply: 230V AC
- Technology: high frequency at 5.8 Ghz
- Output signal: < 5 mW
- Load: 1000W for incandescent lamps
500VA for fluorescent lamps
- Detection angle: **360° vertical**
100° horizontal
- Beam range: **from 0.5 to 6 m** in continuous mode
- Twilight: from 0.5 to 2,000 Lux
- Timer: **from 3 sec. to 30 min.**
- Manual control (with external switch): switchable for up to 4 hours
- Protection degree: **IP 20 for indoor use**
- Complete with support for angle mounting (indoor and outdoor) and for duct inlet
- Dimensions: 113 x 75 x 34 mm
- Colour: polar white

Articolo Item	Angolo di rilev. Det. angle	Portata fascio Beam range	Grado di prot. Protect. degree		€
HF.320	360° verticale vertical 100° orizzontale horizontal	6 m (max)	IP 20	6	63,25



MINIFLOOD

CE

Proiettore costruito in lega di alluminio pressofuso, corpo del rilevatore in materiale plastico.

Equipaggiato con la lampada alogena lineare da 120 W - durata 2.000 ore

- Alimentazione: 230/240 V~ 50 Hz
- Temporizzatore: da **5 sec. a 5 min. circa**
- Crepuscolare: da **20 a 2000 Lux**
- Grado di protezione: **IP 44**
- Colore corpo: nero

Projector constructed in die-cast aluminium alloy, detector body in plastic material.

Equipped with linear 120 W halogen lamp - duration 2,000 hours

- *Power supply: 230/240 V~ 50 Hz*
- *Timer: **from 5 sec. to 5 min. approx.***
- *Twilight: **from 20 to 2000 Lux***
- *Protection degree: **IP 44***
- *Body colour: black*

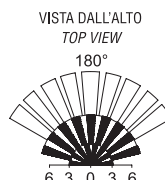
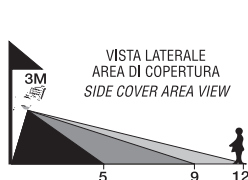

Energysafe



Articolo Item	Angolo di rilev. Det. angle	Portata fascio Beam range	Grado di prot. Protect. degree		€
RH.150	180°	12 m	IP 44	12	24,55



MAXIFLOOD

CE

Proiettore costruito in lega di alluminio pressofuso, corpo del rilevatore in materiale plastico.

Equipaggiato con la lampada alogena lineare da 400 W - durata 2.000 ore

- Alimentazione: 230/240 V~ 50 Hz
- Temporizzatore: da **5 sec. a 8 min. circa**
- Crepuscolare: da **20 a 2000 Lux**
- Grado di protezione: **IP 44**
- Colore corpo: nero

Projector constructed in die-cast aluminium alloy, detector body in plastic material.

Equipped with linear 400 W halogen lamp - duration 2,000 hours

- *Power supply: 230/240 V~ 50 Hz*
- *Timer: **from 5 sec. to 8 min. approx.***
- *Twilight: **from 20 to 2000 Lux***
- *Protection degree: **IP 44***
- *Body colour: black*

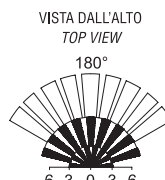
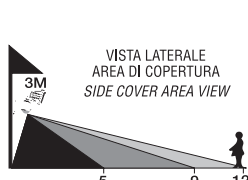

Energysafe



Articolo Item	Angolo di rilev. Det. angle	Portata fascio Beam range	Grado di prot. Protect. degree		€
RH.500	180°	12 m	IP 44	6	26,00



REMOTEFLOOD

CE

Proiettore alogeno telecomandabile a distanza

- Set composto da 1 proiettore (150 o 500 W) + 1 telecomando a 16 canali
- Consente l'attivazione del proiettore senza effettuare nessun cablaggio di comando

Remotely controlled halogen projector

- *Set consisting of 1 projector (150 or 500 W) + 1 16-channel remote control*
- *It lets you activate the projector without making any control wiring*

Caratteristiche proiettori

- Alimentazione: 230/240 V~ 50 Hz
- Completo di lampada alogena lineare
- Colore corpo: nero

Projector features

- *Power supply: 230/240 V~ 50 Hz*
- *Complete with linear halogen lamp*
- *Body colour: black*

Caratteristiche telecomando

- Canali: 16
- Alimentazione: **batteria A23 - 12 V**
- Raggio trasmissione: **50 m in campo libero**
- Dimensioni: 85x44x22 mm

Remote control features

- *Channels: 16*
- *Power supply: **battery A23 - 12 V***
- *Transmission ray: **50 m in free field***
- *Dimensions: 85x44x22 mm*

Articolo Item	Angolo di rilev. Det. angle	Descrizione Description	Grado di prot. Protect. degree		€
TLRX.150	180° verticale, 60° orizzontale 180° vertical, 60° horizontal	Set da 150 W 150 W Set	IP 55	1	65,00
TLRX.500	180° verticale, 60° orizzontale 180° vertical, 60° horizontal	Set da 500 W 500 W Set	IP 55	1	73,00

**MASSIMA
SICUREZZA**

**MAXIMUM
SECURITY**



SMARTFLOOD

Energysafe

Faretto LED con rilevatore di presenza e pannello ad energia solare.

L'energia accumulata durante il giorno dal pannello solare (elemento separato) viene immagazzinata dalle batterie ricaricabili (incluse).

Grazie al sensore crepuscolare incorporato il faretto si accende automaticamente solo di notte e quando qualcuno transita nel raggio d'azione del rilevatore di presenza.

- Il faretto LED fa risparmiare 3 volte energia**
- 1) il pannello solare fornisce l'energia necessaria senza costi aggiuntivi
 - 2) il faretto LED consente un consumo limitato di energia ed una lunga autonomia
 - 3) il rilevatore fa accendere il faretto solo quando serve

NON NECESSITA DI NESSUNA INSTALLAZIONE ELETTRICA

Caratteristiche tecniche:

Pannello solare

- tipo di cella: monocristallino 10 V / 2,5 W (durata > 20 anni)
- Grado di protezione: IP 65
- Dimensioni: 150 x 120 mm
- Supporto snodabile: 360° orizzontale
90° verticale
- Cavo di collegamento tra pannello e faretto: L = 5 m ca.

Faretto snodabile e orientabile

- 45 LED ad alta luminosità, bianchi
- Temperatura di colore: 6500°K
- Autonomia: 5 ore ca. (con batteria totalmente carica)
- Altezza di installazione: 1÷3 m
- Grado di protezione: IP 44
- Dimensioni: 180 x 160 mm

Rilevatore di presenza

- Angolo di rilevamento: **180°**
- Portata del fascio: **8 m**
- Temporizzatore: **da 8 sec. a 180 sec. ± 10 sec.**
- Crepuscolare: da 10 a 2000 Lux
- Batterie ricaricabili: litio 7,4 V - 3000 mAh
- Selettore: ON - OFF - Automatico
- Ingresso ausiliario per alimentatore
- Grado di protezione: IP 44
- Colore: bianco
- Dimensioni: 130 x 100 x 100 mm

Alimentatore ausiliario



- Alimentazione: 230 V~ 50 Hz
- Secondario: 9 V = 1000 mA
- Cavetto L: 180 cm
- Grado di protezione: IP 20

LED spotlight with motion detector and solar energy panel.

The energy accumulated during the day by the solar panel (separate element) is stored by the rechargeable batteries (included).

Thanks to the built-in twilight sensor the spotlight switches on automatically only at night and when someone passes within the range of action of the motion detector.

The LED spotlight makes you save 3 times as much energy

- 1) the solar panel supplies the required energy with no additional costs
- 2) the LED spotlight assures limited energy consumption and long autonomy
- 3) the detector switches the spotlight on only when needed

IT REQUIRES NO ELECTRICAL INSTALLATION

Technical features:

Solar panel

- type of cell: mono-crystalline 10V/2.5W (duration > 20 years)
- Protection degree: IP 65
- Dimensions: 150 x 120 mm
- Swivel support: 360° horizontal
90° vertical
- Connecting cable between panel and spotlight: L = 5 m approx.

Swivel and adjustable spotlight

- 45 high brightness LEDs, white
- Colour temperature: 6500°K
- Autonomy: 5 ore approx. (with fully charged battery)
- Installation height: 1÷3 m
- Protection degree: IP 44
- Dimensions: 180 x 160 mm

Motion detector

- Detection angle: **180°**
- Beam range: **8 m**
- Timer: **from 8 sec. to 180 sec. ± 10 sec.**
- Twilight: from 10 to 2000 Lux
- Rechargeable batteries: lithium 7.4 V - 3000 mAh
- Selector: ON - OFF - Automatic
- Auxiliary input for driver
- Protection degree: IP 44
- Colour: white
- Dimensions: 130 x 100 x 100 mm

Auxiliary driver



- Power supply: 230 V~ 50 Hz
- Secondary: 12 V = 1000 mA
- Cable L: 180 cm
- Protection degree: IP 20

Articolo Item	Angolo di rilev. Det. angle	Portata fascio Beam range	Grado di prot. Protect. degree		€
SM.77	180°	8 m	Pannello Panel IP 65 Faretto e rilevatore Spotlight and detector IP 44	1/4	118,45

Altri fari led solari nel catalogo lighting | Other solar led flood lights in lighting catalogue

Spina/presa telecomandata

Remotely controlled plug/socket

LYVIA



Ricevitori e trasmettitori possono essere programmati e combinati liberamente tra loro con estrema facilità. Il segnale viene trasmesso tramite onde radio sulla frequenza di 433,92 Mhz. Gli apparecchi si codificano in autoapprendimento evitando false attivazioni.

Receivers and transmitters may be freely programmed and combined with the utmost ease. The signal is transmitted via radio waves on the 433.92 Mhz frequency. The appliances are coded in self-learning mode preventing false starts.

Kit base composto da:

- Presa ON/OFF art. RF.170.I
- Telecomando art. TF.65

Basic kit consisting of:

- ON/OFF socket item RF.170.I
- Remote control item TF.65

Articolo Item	Descrizione Description		€
* LYD.60	Kit spina/presa + telecomando Plug/socket + remote control kit	10	23,25



Spina/presa telecomandata ON/OFF

Da utilizzare con il telecomando TF.65

- Consente di comandare qualsiasi tipo di carico in modo "acceso/spento"
- Spina italiana 16A 2p+T
- Presa italiana 10/16A - 2 P+T con alveoli protetti
- Alimentazione 230V ~ 50Hz
- Portata max 3600 W
- Pulsante per comando manuale ON/OFF
- Grado di protezione: IP 20
- Classe di isolamento: II

ON/OFF remotely controlled plug/socket

To be used with the TF.65 remote control

- It lets you control any type of load in "on/off" mode
- Italian plug 16A 2p+T
- Italian socket 10/16A - 2 P+T with child protection
- Power supply 230V ~ 50Hz
- Max load: 3600 W
- ON/OFF button for manual control
- Protection degree: IP 20
- Insulation class: II

Articolo Item	Descrizione Description		€
* RF.170.I	Spine/Presse telecomandata Remote controlled plug/socket	10	12,80



Telecomando portatile

- Funziona con 2 batterie LR44-1,5V (fornite in dotazione)
- Consente di comandare indipendentemente fino a 4 apparecchi riceventi
- Pulsante "tutto acceso"
- Pulsante "tutto spento"
- Portata: 30 m in campo libero
- Grado di protezione: IP 20
- Classe di isolamento: II

Portable remote control

- Works with 2 batteries LR44-1,5V (supplied)
- It lets you independently control up to 4 receiving appliances
- All-on push button
- All-off push button
- Range: 30 m in free area
- Protection degree: IP 20
- Insulation class: II

Articolo Item	Descrizione Description		€
*TF.65	Telecomando Remote control	10	9,26



ANALOGICA ELETTROMECCANICA

- Inseribile nelle prese di corrente già esistenti.
- Classe di isolamento: I
- Grado di protezione: IP 20.
- **10 A programma giornaliero**
- Spina/presa italiana 10A 220 ÷ 240V ~ 50Hz con terra centrale ed alveoli protetti
- 96 comandi giornalieri (minimo intervento: 15 minuti)
- Movimento sincrono, senza riserva di carica
- Selettore manuale per interruzione programma
- Carico: 2200 W
- Colore: bianco

ANALOGUE ELECTROMECHANICAL

- It can be inserted in existing power outlets.
- Insulation class: I
- Protection degree: IP 20.
- **10 A daily program**
- Italian plug/socket 10A 220 ÷ 240V ~ 50Hz with central earth and child protection
- 96 daily commands (minimum action: 15 minutes)
- Synchronous movement, without power reserve
- Manual switching for program interruption
- Load: 2200 W
- Colour: white

Articolo | Item

Descrizione | Description



* 52650

Presca analogica 10 A | 10 A Analogue socket

6/48

6,00



ANALOGICA ELETTROMECCANICA

- Inseribile nelle prese di corrente già esistenti.
- Classe di isolamento: I
- Grado di protezione: IP 20.
- **16A programma giornaliero**
- Spina: 16A 220 ÷ 240V ~ 50Hz con terra centrale
- Presca italiana bivalente 10/16 A con terra centrale ed alveoli protetti
- 96 comandi giornalieri (minimo intervento: 15 minuti)
- Movimento sincrono, senza riserva di carica
- Selettore manuale per interruzione programma
- Carico: 3600 W
- Colore: bianco

ANALOGUE ELECTROMECHANICAL

- It can be inserted in existing power outlets.
- Insulation class: I
- Protection degree: IP 20.
- **16A daily program**
- Plug: 16A 220 ÷ 240V ~ 50Hz with central earth
- Italian 10/16 A two-pole socket with central earth and child protection
- 96 daily commands (minimum action: 15 minutes)
- Synchronous movement, without power reserve
- Manual switching for program interruption
- Load: 3600 W
- Colour: white

Articolo | Item

Descrizione | Description



* 52660

Presca analogica 16 A | 16 A Analogue socket

6/48

6,00



DIGITALE "HOME-SAFE"

- **Programmaggio giornaliero, settimanale + random****
- Display a cristalli liquidi con visualizzazione dell'ora - minuti - situazione del contatto con il giorno della settimana
- Possibilità di comando manuale occasionale (ON-OFF)
- Facilità di programmazione mediante 8 tasti
- Intervento casuale, che protegge la casa durante l'assenza di persone
- Riserva di carica di oltre 100 ore
- Intervallo minimo: 1 minuto
- Spina: 16 A 220 ÷ 240V ~ 50Hz con terra centrale
- Presca italiana bivalente 10/16 A con terra centrale ed alveoli protetti
- Carico: 3600 W
- Colore: bianco

DIGITAL "HOME-SAFE"

- **Daily, weekly + random** program**
- Liquid crystal display showing hour - minutes - contact situation with day of the week
- Possibility of occasional manual control (ON-OFF)
- Easy programming with 8 buttons
- Random intervention, that protects the house during your absence
- Over 100 hours charge reserve
- Minimum interval: 1 minute
- Plug: 16 A 220 ÷ 240V ~ 50Hz with central earth
- Italian 10/16 A socket with central earth and child protection
- Load: 3600 W
- Colour: white

**Random = intervento casuale che permette l'accensione e lo spegnimento di una luce (o altra utenza) ad intervalli irregolari durante il periodo programmato

**Random = random intervention that switches on or off a light (or other fixture) at irregular intervals during the programmed period

Articolo | Item

Descrizione | Description



* 52675

Presca digitale 16 A | 16 A digital socket

12

13,35



SATURN

Campanello portatile senza fili

Funziona totalmente a batterie
8 diverse melodie selezionabili
Dimensioni compatte
Frontalino luminoso blu
Selettore per: solo luce, solo suono, combinazione suono/lampeggio
Selezione flash o luce fissa blu
Regolazione volume
Intensità suono: 87 dB
Ricevitore: 130 x 63 x 40 mm
Colore: bianco ghiaccio
Funziona a batterie stilo 3 x AA (non fornite)
Si possono memorizzare sino a 4 pulsanti con altrettante differenti melodie
Codificabile
Foro posteriore per fissaggio a parete
La confezione include un pulsante trasmettitore
art. SC.2103 per uso all'esterno IP44, completo di batteria bottone 3V - CR2032
Portata 150 metri (in campo libero)

Wireless portable chime

Fully battery operating
8 different selectable melodies
Compact dimensions
Blue lighting front plate
Selector for: only light, only sound, sound & flash combination
Selector for flash or steady blu light
Volume control
Sound output: 87 dB
Receiver: 130 x 63 x 40 mm
Colour: polar white
Works with R6 batteries 3 x AA (not supplied)
Up to 4 buttons may be memorised with as many different melodies
Codeable
Back side hole for wall fixing
The package includes a transmitter button item
SC.2103 for outdoor use IP44, complete with 3V - CR2032 battery
Range 150 metres (in free field)

Articolo Item	Descrizione Description		€
* AS.14	Campanello portatile senza fili luminoso Wireless portable lighting chime	6/24	31,70



TREMENS

**A VIBRAZIONE
WITH VIBRATION**

Carillon portatile senza fili con vibrazione

Ideale per luoghi di lavoro rumorosi e per persone ipoudenti
8 diverse melodie selezionabili
Selettore per l'esclusione vibrazione e/o suoneria
Clip di aggancio alla cintura nel caso si usasse l'apparecchio come cercapersona
Dimensioni compatte
Intensità suono: 83 dB
Codificabile
Ricevitore: 107 x 48 x 32 mm
Colore: bianco ghiaccio
Funziona a batterie stilo 2xAA (non fornite)
Si possono memorizzare sino a 4 pulsanti con altrettante differenti melodie
La confezione include un pulsante trasmettitore
art. SC.2103 per uso all'esterno IP44, completo di batteria bottone 3V - CR2032
Portata 100 metri (in campo libero)

Wireless portable chime with vibration

Ideal for noising working place and for deaf person
8 different selectable melodies
Selector for bypassing vibration and/or ring-tone
Belt clip for using the appliance as a pager
Compact dimensions
Sound Output: 83 dB
Codeable
Receiver: 107 x 48 x 32 mm
Colour: polar white
Works with R6 batteries 2xAA (not supplied)
Up to 4 buttons may be memorised with as many different melodies
The package includes a transmitter button item
SC.2103 for outdoor use IP44, complete with 3V - CR2032 battery
Range 100 metres (in free field)

Articolo Item	Descrizione Description		€
* AS.328	Carillon portatile senza fili con vibrazione Wireless portable chime with vibration	6/24	18,50



DOCKING

Campanello senza fili ricaricabile

- Base per ricarica ad induzione
- Suoneria portatile, 8 diverse melodie, con ricarica ad induzione = nessun cambio batterie
- Pulsante trasmettitore

Base: 110 x 68 x 26 mm
 Colore: bianco ghiaccio
 Equipaggiata con spina 2p - 10A italiana

Ricevitore: 130 x 64 x 30 mm
 Colore: bianco ghiaccio
 Con lampeggiante blu
 Dimensione compatte
 Anello frontale luminoso
 Aggancio magnetico tra base e ricevitore
 Selettore per: solo lampeggio, solo suono, combinazione suono/lampeggio
 Selezione colore flash: blu, verde, rosso
 Regolazione volume
 Interruttore ON/OFF
 Intensità suono: 90 dB

Ricarica ad induzione su supporto "base"

Si possono memorizzare sino a 4 pulsanti con altrettante differenti melodie

La confezione include un pulsante trasmettitore
 art. SC.2103 per uso all'esterno IP44, completo di batteria bottone 3V - CR2032
Portata 150 metri (in campo libero)

Wireless rechargeable & portable chime

- Base for induction charge
- Portable door chime with 8 different melodies and inductive charge = no battery replacement
- Transmitter button

Base: 110 x 68 x 26 mm
 Colour: polar white
 Equipped with 10A 2p italian style plug

Receiver: 130 x 64 x 30 mm
 Colour: polar white
 With blue flash
 Compact dimensions
 Lighting front ring
 Magnetic junction between receiver & base
 Selector for: only flash, only sound, sound & flash combination
 Selector for blue, green, red flash
 Volume control
 ON/OFF switch
 Sound output: 90 dB

Induction recharge when it's placed on the docking base

Up to 4 buttons may be memorised with as many different melodies

The package includes a transmitter button item SC.2103 for outdoor use IP44, complete with 3V - CR2032 battery
Range 150 metres (in free field)

Articolo Item	Descrizione Description		€
* AS.2309	Campanello portatile ricaricabile senza fili lampeggiante Wireless rechargeable portable flashing chime	1/6	42,75



VISITOR

Campanello portatile senza fili, lampeggiante

Oltre al suono, si accende una luce lampeggiante.
 Possibilità di escludere la suoneria.
 8 diverse melodie selezionabili.
 Regolazione del volume.
 Codificabile.

Ricevitore: 157 x 98 x 38 mm
 Colore: bianco ghiaccio
 Funziona a batterie mezza torcia 2 x C (non fornite)
 Si possono memorizzare sino a 4 pulsanti con altrettante differenti melodie
La confezione include un pulsante trasmettitore
 art. SC.2103 per uso all'esterno IP44, completo di batteria bottone 3V - CR2032
Portata 200 metri (in campo libero)

Wireless portable chime, with flashing light

In addition to the sound, a flashing light switches on.
 Possibility to bypass the ring-tone.
 8 different selectable melodies.
 Volume adjustment.
 Codeable.

Receiver: 157 x 98 x 38 mm
 Colour: polar white
 Works with R14 batteries 2 x C (not supplied)
 Up to 4 buttons may be memorised with as many different melodies
The package includes a transmitter button item SC.2103 for outdoor use IP44, complete with 3V - CR2032 battery
Range 200 metres (in free field)

Articolo Item	Descrizione Description		€
* AS.335	Campanello portatile senza fili lampeggiante Wireless portable flashing chime	6	44,65



150 m

VENUS

RISPARMIA
LE BATTERIE

SAVE ON
BATTERIES

CE

Campanello senza fili con spina/presa "passante"

Per non perdere la presa
Possibilità di collegare utilizzatori
8 diverse melodie selezionabili
Codificabile
Colore: bianco ghiaccio
Intensità suono: 84 dB
Ricevitore: 125 x 70 x 40 mm con spina italiana
16A 2p+ \equiv 250 V~ e presa bipasso 10/16A 2p+ \equiv
con alveoli protetti.
Si possono memorizzare sino a 4 pulsanti con
altrettante differenti melodie.
La confezione include un pulsante trasmettitore
art. SC.2103 per uso all'esterno IP44, completo di
batteria bottone 3V - CR2032
Portata 150 metri (in campo libero)

Plug-in wireless chime with socket

Don't loose any socket
8 different selectable melodies
Codeable
Colour: polar white
Sound output: 0 84 dB
Receiver: 125 x 70 x 40 mm with Italian 16A plug
2p+ \equiv for 250 V~ mains voltage power supply
and 10/16A 2p+ \equiv socket with child protection.
Up to 4 buttons may be memorised with as many
different melodies.
The package includes a transmitter button
SC.2103 for outdoor use IP44, complete with
3V - CR2032 battery
Range 150 metres (in free field)

Articolo Item	Descrizione Description		€
* AS.309	Campanello portatile senza fili a spina Plug-in wireless portable chime	6	32,70



150 m

METALLO

CE

Campanello senza fili dalla forma e dal suono del tradizionale campanello con diffusore metallico

Timpano in metallo verniciato nero, diametro 112 mm.
Base in materiale plastico.
Suono metallico intenso: 95 dB
Funziona a batterie mezza torcia 2xC (non fornite)
Dimensioni: Ø112 mm x 76 mm (H)
Si possono memorizzare sino a 4 diversi pulsanti
La confezione include un pulsante trasmettitore
art. SC.2103 per uso all'esterno IP44, completo di
batteria bottone 3V - CR2032
Portata: 150 metri (in campo libero)

Wireless chime in traditional shape and sound of chime with metal diffuser

Black painted metal drum, diameter 112 mm.
Base in plastic material.
Intense metal sound: 95 dB
Works with R14 batteries 2xC (not supplied)
Dimensions: Ø112 mm x 76 mm (H)
Up to 4 different buttons may be memorised
The package includes a transmitter button
art. SC.2103 for outdoor use IP44, complete with
3V - CR2032 battery
Range: 150 metres (in free field)

Articolo Item	Descrizione Description		€
* AS.5001	Campanello senza fili con diffusore metallico Wireless portable chime with metal diffuser	4	43,90



200 m

TWIN

CE

Campanello senza fili dotato di 2 altoparlanti Bang & Olufsen ad altissima qualità del suono

Consente di riprodurre, con una incredibile purezza del suono, le più famose melodie come: Big Ben, Westminster, etc.
Suono di alta intensità: 95 dB
Controllo del volume
Selettore esclusione volume
8 diverse melodie selezionabili
Funziona a batterie mezza torcia 2xC (non fornite)
Dimensioni: 124x164x42 mm
Si possono memorizzare sino a 4 pulsanti con altrettante differenti melodie
La confezione include un pulsante trasmettitore
art. SC.2103 per uso all'esterno IP44, completo di
batteria bottone 3V - CR2032
Portata: fino a 200 metri (in campo aperto)

Wireless chime with 2 extremely high sound quality Bang & Olufsen speakers

It lets you reproduce with an amazingly pure sound the most famous melodies such as: Big Ben, Westminster, etc.
High intensity sound: 95 dB
Volume control
Volume disable selector
8 different selectable melodies
Works with R14 batteries 2xC (not supplied)
Dimensions: 124x164x42 mm
Up to 4 buttons may be memorised with as many different melodies
The package includes a transmitter button
art. SC.2103 for outdoor use IP44, complete with
3V - CR2032 battery
Range: up to 200 metres (in open field)

SUONO DI
ALTA QUALITÀ
BANG &
OLUFSEN

HIGH
QUALITY BANG
& OLUFSEN
SOUND

Articolo Item	Descrizione Description		€
* AS.3007	Campanello senza fili con 2 altoparlanti Portable wireless chime with 2 speakers	4	43,65



Kit carillon

**premendo il pulsante.....
suonano l'orologio da parete e il
carillon portatile!**

L'orologio che incorpora una suoneria senza filo, si può appendere in casa. Il campanello portatile ausiliario può essere posizionato ovunque (in cantina, in garage, in giardino, in mansarda). In questo modo si viene raggiunti ovunque dal suono.

Pulsante trasmettitore (art. SC.313):
86x36x20 mm, per esterno IP 44
Funziona con 1 batteria bottone 3V CR 2032

Portata 100 m (in campo libero)

Ricevitore: elegante orologio analogico Ø 255 mm
Codificabile
Colore: bianco ghiaccio
Funziona con 1 batteria stilo AA (non fornita)

Ricevitore portatile: 95x60x28 mm
8 diverse melodie selezionabili
Codificabile
Colore: bianco ghiaccio
Funziona con 2 batterie stilo AA (non fornite)
Clip di aggancio alla cintura nel caso si usasse come cercapersone

**press the button.... and the wall
clock and portable chime will
sound!**

The clock has a built-in wireless chime and can be hung in the home. The auxiliary portable chime may be positioned anywhere (in the basement, in the garage, in the garden, in the attic). In this way you will be reached by sound anywhere.

Transmitter button (item SC.313):
86x36x20 mm, for outdoor IP 44
Works with 1 3V CR 2032 battery

Range 100 m (in free field)

Receiver: elegant analogue clock Ø 255 mm
Codeable
Colour: polar white
Works with R6 battery 1xAA (not supplied)

Portable receiver: 95x60x28 mm
8 different selectable melodies
Codeable
Colour: polar white
Works with R6 batteries 2xAA (not supplied)
Belt clip for using as a pager

Articolo Item	Descrizione Description		€
* AS.329	Kit carillon (3 pezzi) Chime kit (3 pieces)	4	24,45
Ricambio / spare part			
SC.313	Pulsante per esterno IP 44 Outdoor button IP 44	1/10	9,92

Accessori per carillons senza filo

Accessories for wireless chimes



EXTENDER



Ripetitore di segnale 120 x 94 x 24 mm
Colore: bianco-ghiaccio con inserto grigio
Funziona a batterie stilo 4xAA
Portata 50 metri
Con questo apparecchio si può estendere la portata dei campanelli portatili: AS.14 - AS.309 - AS.328 - AS.335 - AS. 329 - AS.5001 - AS.3007 - AS.2309
Viene consigliata l'estensione massima di 2 ripetitori.

Signal repeater 120 x 94 x 24 mm
Colour: polar white with grey insert
Works with R6 batteries 4xAA
Range 50 meters
With this appliance, may be extended the range of portable chimes: AS.14 - AS.309 - AS.328 - AS.335 - AS. 329 - AS.5001 - AS.3007 - AS.2309
Is recommended extension of maximum 2 repeaters.

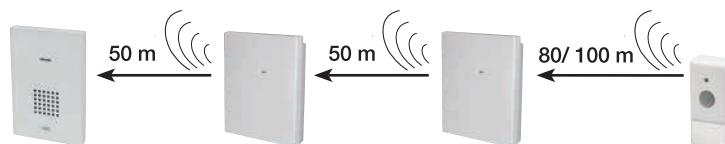

Articolo Item	Descrizione Description		€
* AS.300	Ripetitore di segnale Signal repeater	6	29,75



PULSANTI | BUTTONS

Ricambi carillons senza filo
Pulsanti trasmettitori per esterno completi di batteria bottone 3V - CR2032
Colore: bianco ghiaccio
Da utilizzarsi con i carillons AS.14 - AS.309 - AS.328 - AS.335 - AS.5001 - AS.3007 - AS.2309

Wireless chime spare parts
Outdoor transmitter buttons complete with battery button 3V - CR2032
Colour: polar white
To be used with chimes AS.14 - AS.309 - AS.328 - AS.335 - AS.5001 - AS.3007 - AS.2309

Articolo Item	Descrizione Description		€
* SC.3106	Pulsante stagno per esterno IP 55 Waterproof outdoor button IP 55	1/10	11,90
* SC.2103	Pulsante per esterno IP 44 Outdoor button IP 44	1/10	10,70

*I prodotti contraddistinti da asterisco sono in confezione blisterata già pronta per gli espositori di vendita.
*Products marked by an asterisk are in a blister package ready for shop displays.



INTERRUTTORE ECOLOGICO

Con questo apparecchio si possono prevenire gli effetti dannosi al corpo umano generati dai campi elettromagnetici.

Il relè è in grado di interrompere l'alimentazione dopo lo spegnimento di tutti i carichi ad esso collegati in serie.

- adatto per montaggio su binario DIN 46277
- ingombro: **17,5 x 45 x 55 mm**
- carico: 16A 250 V~
- contatto: 1 N.A
- alimentazione: 230 V~
- corrente costante: 10 mA
- ritardo di accensione: 0,3 sec.

ECOLOGICAL SWITCH

With this appliance you can prevent the harmful effects generated by electromagnetic fields to the human body.

The relay is able to disconnect power supply once all series connected loads are turned off.

- suitable for installation on DIN 46277 track
- overall dimensions: **17,5 x 45 x 55 mm**
- load: 16A 250 V~
- contact: 1 N. O.
- power supply: 230 V~
- constant current: 10 mA
- switch-on delay: 0,3 sec.

Articolo | Item

Descrizione | Description



€

FR12.1

Interruttore ecologico | Ecological switch

1

104,70

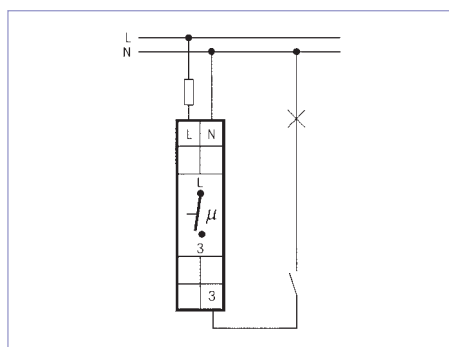

Collegamento elettrico

I conduttori neutro e di terra devono essere collegati direttamente sulla presa a parete, mentre la fase viene controllata dal relè.

Posizioni dell'interruttore a rotazione FR 12.1 situato su "apprendere"

P → = apprendere i valori della corrente

A = autoapprendere

A̅ = non autoapprendere

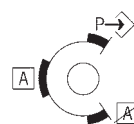

Electrical connection

Neutral and earth conductor must be connected directly on wall socket, while phase is controlled by the relay.

FR 12.1 rotary switch setted on "learn"

P → = learn of current value

A = self-learn

A̅ = not self-learn

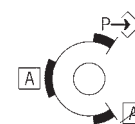

Fase attiva (monitoraggio)

Quando il relè interviene stacca la fase (lampeggia il LED) e nel circuito viene fatta circolare una corrente continua di 50 VDC.

Interruttore a rotazione posizionato su "modi di funzionamento"

ON = in funzione continua

AUTO = funzione automatica, voltaggio di montaggio regolabile

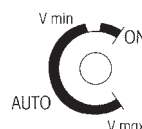

Monitoring voltage

When the relay operate, it disconnects phase (LED is flashing) and 50V DC is applied to the circuit.

Rotary regulator "monitoring voltage"

ON = continuously on

AUTO = automatic function, adjustable monitoring voltage

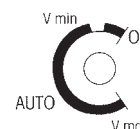

Elemento per il carico di base GLE con cavetto di connessione.

Può essere allacciato in parallelo a un carico, a una presa o a una presa multipla per aumentare il carico e mantenere inserito l'interruttore ecologico. Interviene solo in presenza di un carico, anche minimo. Senza carichi non è in grado di mantenere inserito il FR12.1. Può anche essere installato a valle dell'interruttore ecologico, sulla partenza di ogni singola linea.

Element for base GLE load with connecting cord.

It may be connected in parallel to a load, a socket or a multi socket to increase the load and keep the ecological switch on. It is only triggered in the presence of a load, even minimum. Without any loads it is unable to maintain FR12.1 on. It may even be installed downline of the ecological switch, on the start of each individual line.

Articolo | Item

Descrizione | Description



€

GLE

Carico resistivo | Resistive load

1

9,72

APPARECCHI DA INCASSO

BUILT-IN APPLIANCE



Spine e prese IEC 320/EN 60320

IEC 320/EN 60320 Plugs and sockets

LYVIA



- spina volante dritta
- antiurto
- **65°C max**

- *movable straight plug*
- *shockproof*
- **65°C max**

Articolo Item	Volt	A	Colore Colour		€
1038.S	250 V	10	nero black	10	4,02



- presa volante dritta
- antiurto
- adatta per tutti i tipi di innesti
- **155°C max**

- *movable straight socket*
- *shockproof*
- *suitable for all types of inserts*
- **155°C max**

Articolo Item	Volt	A	Colore Colour		€
980.S	250 V	10	nero black	25	3,00



- presa volante a squadra
- antiurto
- adatta per tutti i tipi di innesti
- **155°C max**

- *movable bracket socket*
- *shockproof*
- *suitable for all types of inserts*
- **155°C max**

Articolo Item	Volt	A	Colore Colour		€
1248.S	250 V	10	nero black	10	4,15

Spine e prese IEC 320/EN 60320

IEC 320/EN 60320 Plugs and sockets

LYVIA



- presa volante a pipa
- antiurto
- adatta per tutti i tipi di innesti
- **155°C max**
- *movable pipe socket*
- *shockproof*
- *suitable for all types of inserts*
- **155°C max**

Articolo Item	Volt	A	Colore Colour		€
1148.5	250 V	10	nero black	10	4,15



- spina da incasso SNAP-IN autobloccante
- attacchi FAST-ON 6,3 mm
- **65°C max** per applicazioni fredde
- per pannelli spessore 1,5 mm²
- *SNAP-IN self-locking built-in plug*
- *FAST-ON 6.3 mm connections*
- **65°C max** for cold applications
- *For 1,5 mm² thickness panels*

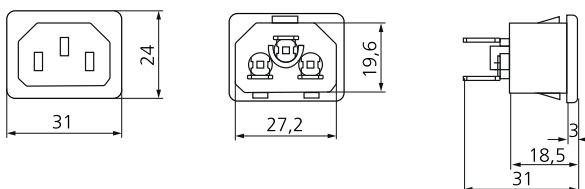

Articolo Item	Volt	A	Colore Colour		€
830037	250 V	6	nero black	50	2,52



- spina da incasso con fissaggio a vite
- attacchi FAST-ON 6,3 mm
- **65°C max** per applicazioni fredde
- *built-in plug for screw fixing*
- *FAST-ON 6.3 mm connections*
- **65°C max** for cold applications

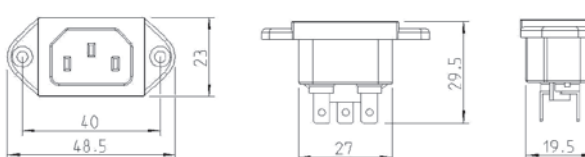

Articolo Item	Volt	A	Colore Colour		€
830016	250 V	10	nero black	50	2,35

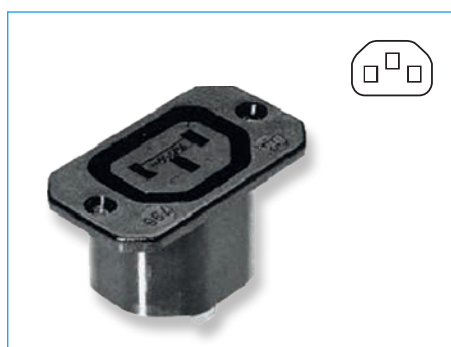

- presa da incasso con fissaggio a vite
- attacchi FAST-ON 6,3 mm
- **65°C max** per applicazioni fredde
- *built-in plug for screw fixing*
- *FAST-ON 6.3 mm connections*
- **65°C max** for cold applications

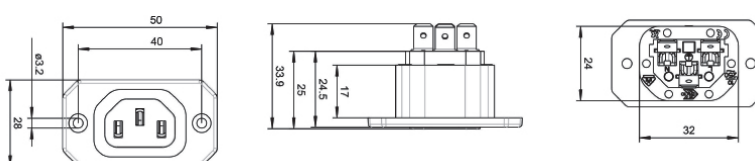

Articolo Item	Volt	A	Colore Colour		€
840038	250 V	6	nero black	50	2,52

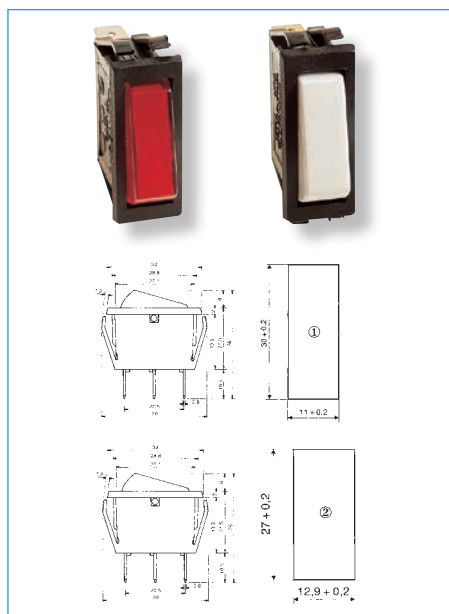

- serie in conformità alle norme CEE 24 per apparecchi di classe II
- T. 125°C
- contatti in argento
- corpo in termoplastico nero
- tasto in termoplastico bianco
- fissaggio autobloccante su pannelli 0,7 - 2,5 mm
- attacchi Fast-on (su richiesta a saldare)

- series in compliance with EEC 24 standards for class II appliances
- T. 125°C
- silver contacts
- black thermoplastic body
- white thermoplastic switch
- self-locking fixing on 0.7 - 2.5 mm panels
- Fast-on connections (weldable on demand)

Articolo Item	Descrizione Description	Modello Model	Volt	A		€
8300.34.16	interruttore unipolare one-pole switch	① Cristal	250 V	16	50	1,12
8302.34.16	deviatore unipolare one-pole diverter	① Cristal	250 V	16	50	1,24
8305.34.00	pulsante unipolare one-pole button	① Cristal	250 V	16	50	1,35
8200.34.36.R	interr. unipolare lum. rosso red light one-pole switch	① Cristal	250 V	16	50	1,42
8200.34.36.V	interr. unipolare lum. verde green light one-pole switch	① Cristal	250 V	16	50	1,42
8200.34.36.B	interr. unipolare lum. trasparente clear light one-pole switch	① Cristal	250 V	16	50	1,37
8100.34.16	interruttore unipolare one-pole switch	② Zenith	250 V	16	50	1,08
8102.34.16	deviatore unipolare one-pole diverter	② Zenith	250 V	16	50	1,24

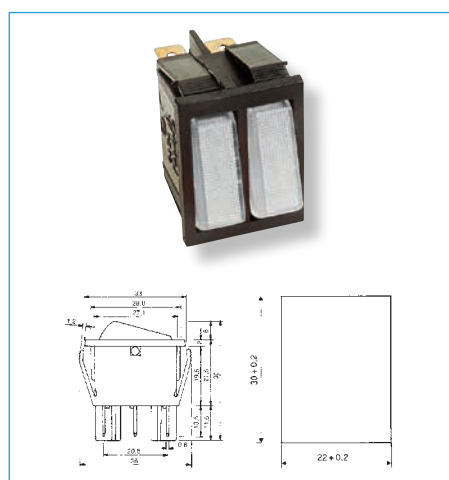

- serie in conformità alle norme CEE 24 per apparecchi di classe II
- T. 125°C
- contatti in argento
- corpo in termoplastico nero
- tasto in termoplastico bianco
- fissaggio autobloccante su pannelli 0,7 - 2,5 mm
- attacchi Fast-on (su richiesta a saldare)

- series in compliance with EEC 24 standards for class II appliances
- T. 125°C
- silver contacts
- black thermoplastic body
- white thermoplastic switch
- self-locking fixing on 0.7 - 2.5 mm panels
- Fast-on connections (weldable on demand)

Articolo Item	Descrizione Description	Modello Model	Volt	A		€
8500.34.00	doppio interruttore bipolare double two-pole switch	Cristal	250 V	16	25	2,56

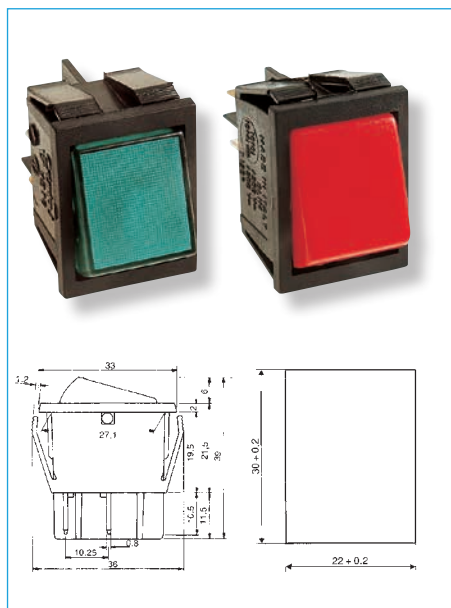

- serie in conformità alle norme CEE 24 per apparecchi di classe II
- T. 125°C
- contatti in argento
- corpo in termoplastico nero
- tasto in termoplastico bianco
- fissaggio autobloccante su pannelli 0,7 - 2,5 mm
- attacchi Fast-on (su richiesta a saldare)

- series in compliance with EEC 24 standards for class II appliances
- T. 125°C
- silver contacts
- black thermoplastic body
- white thermoplastic switch
- self-locking fixing on 0.7 - 2.5 mm panels
- Fast-on connections (weldable on demand)

Articolo Item	Descrizione Description	Modello Model	Volt	A		€
8750.34.00	interruttore bipolare two-pole switch	Cristal	250 V	16	25	1,73
8752.34.00	deviatore bipolare two-pole diverter	Cristal	250 V	16	25	1,81
8755.34.00	pulsante bipolare two-pole button	Cristal	250 V	16	25	2,01
8650.34.36.R	interruttore bipolare lum. rosso red light two-pole switch	Cristal	250 V	16	25	2,26
8650.34.36.V	interruttore bipolare lum. verde green light two-pole switch	Cristal	250 V	16	25	2,26



Versione con coppetta paraspruzzi IP 44 | Version with IP 44 splash guard cover

Articolo Item	Descrizione Description	Modello Model	Volt	A		€
8650.34.36.R.PV	Interruttore bipolare lum. rosso red light two-pole switc	Cristal	250 V	16	100	3,12
8650.34.36.V.PV	Interruttore bipolare lum. verde green light two-pole switch	Cristal	250 V	16	100	3,12



INTERRUTTORE UNIPOLARE

- adatti per piccoli elettrodomestici, apparecchi elettromedicali, corpi illuminanti, lampade da tavolo alogene
- T. 105°C
- corpo e tasto in termoplastico nero
- terminali Fast-on 4,8 x 0,8
- fissaggio autobloccante
- contatti CuZn

ONE-POLE SWITCH

- suitable for small household appliances, electro-medical appliances, lighting fixtures, halogen table lamps
- T. 105°C
- black thermoplastic body and switch
- Fast-on 4.8 x 0.8 terminals
- self-locking fixing
- CuZn contacts

Articolo Item	Descrizione Description	Volt	A		€
9000.34	interruttore unipolare one-pole switch	250 V	6	50	0,93

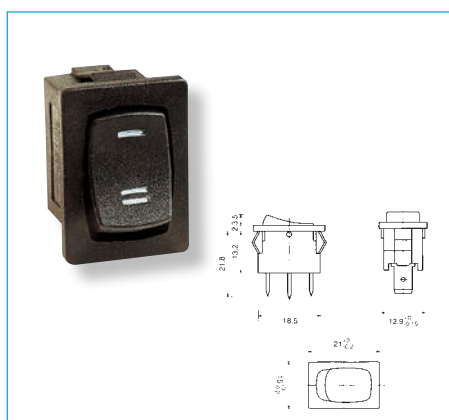

DEVIATORE UNIPOLARE 1-2

- adatti per piccoli elettrodomestici, apparecchi elettromedicali, corpi illuminanti, lampade da tavolo alogene
- T. 105°C
- corpo e tasto in termoplastico nero
- terminali Fast-on 4,8 x 0,8
- fissaggio autobloccante
- contatti CuZn

ONE-POLE DIVERTER 1-2

- suitable for small household appliances, electro-medical appliances, lighting fixtures, halogen table lamps
- T. 105°C
- black thermoplastic body and switch
- Fast-on 4.8 x 0.8 terminals
- self-locking fixing
- CuZn contacts

Articolo Item	Descrizione Description	Volt	A		€
9002.34	deviatore unipolare 1-2 one-pole diverter 1-2	250 V	6	50	1,10

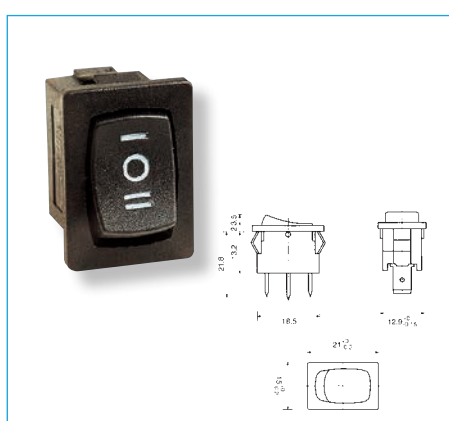

COMMUTATORE UNIPOLARE I-O-II

- adatti per piccoli elettrodomestici, apparecchi elettromedicali, corpi illuminanti, lampade da tavolo alogene
- T. 105°C
- corpo e tasto in termoplastico nero
- terminali Fast-on 4,8 x 0,8
- fissaggio autobloccante
- contatti CuZn

ONE-POLE SWITCH I-O-II

- suitable for small household appliances, electro-medical appliances, lighting fixtures, halogen table lamps
- T. 105°C
- black thermoplastic body and switch
- Fast-on 4.8 x 0.8 terminals
- self-locking fixing
- CuZn contacts

Articolo Item	Descrizione Description	Volt	A		€
9001.34	commutatore unipolare I-O-II one-pole switch I-O-II	250 V	6	50	1,52

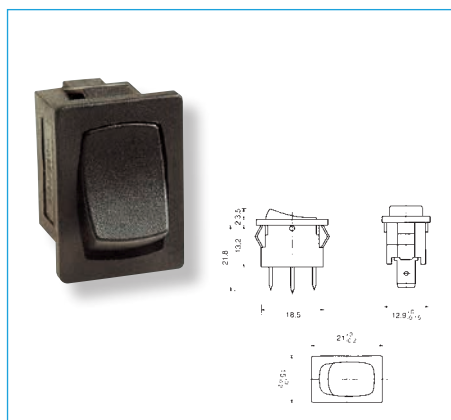

PULSANTE UNIPOLARE

- **adatti per piccoli elettrodomestici, apparecchi elettromedicali, corpi illuminanti, lampade da tavolo alogene**
- T. 105°C
- corpo e tasto in termoplastico nero
- terminali Fast-on 4,8 x 0,8
- fissaggio autobloccante
- contatti CuZn

ONE-POLE BUTTON

- **suitable for small household appliances, electro-medical appliances, lighting fixtures, halogen table lamps**
- T. 105°C
- black thermoplastic body and switch
- Fast-on 4.8 x 0.8 terminals
- self-locking fixing
- CuZn contacts

Articolo Item	Descrizione Description	Volt	A		€
9005.34	pulsante unipolare one-pole button	250 V	6	25	1,03

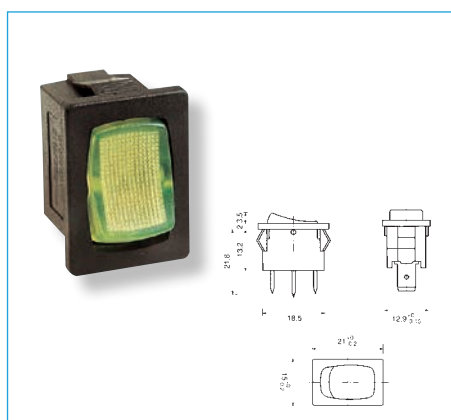

INTERRUTTORI UNIPOLARI LUMINOSI

- **adatti per piccoli elettrodomestici, apparecchi elettromedicali, corpi illuminanti, lampade da tavolo alogene**
- T. 105°C
- corpo e tasto in termoplastico nero
- terminali Fast-on 4,8 x 0,8
- fissaggio autobloccante
- contatti CuZn

ONE-POLE LIGHT SWITCHES

- **suitable for small household appliances, electro-medical appliances, lighting fixtures, halogen table lamps**
- T. 105°C
- black thermoplastic body and switch
- Fast-on 4.8 x 0.8 terminals
- self-locking fixing
- CuZn contacts

Articolo Item	Descrizione Description	Volt	A		€
9010.34.R	interr. unipolare tasto rosso red key one-pole switch	220 V	6	25	1,44
9010.34.VF	interr. unip. tasto verde fluoro day-glo green key one-pole switch	220 V	6	25	1,83

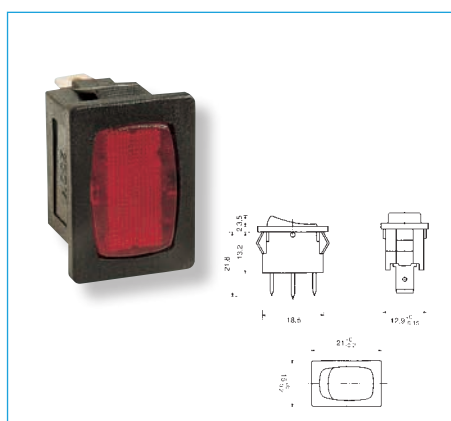

SEGNALATORI LUMINOSI

- **adatti per piccoli elettrodomestici, apparecchi elettromedicali, corpi illuminanti, lampade da tavolo alogene**
- T. 105°C
- corpo e tasto in termoplastico nero
- terminali Fast-on 4,8 x 0,8
- fissaggio autobloccante
- contatti CuZn

LIGHT SIGNALLERS

- **suitable for small household appliances, electro-medical appliances, lighting fixtures, halogen table lamps**
- T. 105°C
- black thermoplastic body and switch
- Fast-on 4.8 x 0.8 terminals
- self-locking fixing
- CuZn contacts

Articolo Item	Descrizione Description	Volt	A		€
9004.34.R	segnalatore luminoso rosso red light signaller	220 V	6	25	1,01
9004.34.VF	segn. luminoso verde fluoro day-glo green light signaller	220 V	6	25	1,53



INTEGRO FLOW



INTEGRO PURE

Una innovativa gamma di prese, interruttori ed apparecchi da incasso per:
An innovative range of sockets, switches and built-in fixtures for:

- mobili
- arredamento
- caravans
- roulotte
- barche da diporto
- industria navale

- furniture
- interior decoration
- caravans
- camping vans
- pleasure boats
- maritime industry



Serie da incasso INTEGRO

Built-in modules INTEGRO series



La nuova serie compatta trova ampio impiego nell'industria dei mobili (mobili da bagno, da cucina, da arredamento) nell'industria delle pareti mobili, delle roulotte e dei campers, delle barche da diporto.

Apparecchiature elettriche da incasso di minimo ingombro.

Colori moderni, linee armoniose e massima completezza, fanno di questo sistema un esclusivo prodotto di alta classe.

Gli apparecchi INTEGRO sono costruiti secondo le principali norme di sicurezza internazionali.

The new compact series is applied in the furniture industry (bathroom and kitchen furniture and interior decoration), in the movable wall industry, camping vans and campers, pleasure boats.

Very compact-sized modules to built-in. Modern colours, harmonious lines and maximum comprehensiveness, make this system an exclusive, high-end product.

INTEGRO fixtures are constructed according to the main international safety standards.

Frutti | Modules

Integro flow

Integro pure

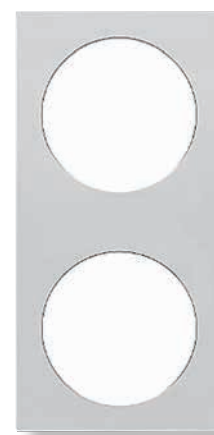
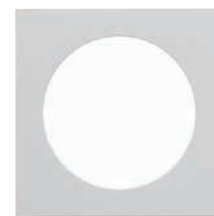



Interruttore unipolare

One-pole switch



Articolo Item	Colore Colour	Volt	A		€
3651.25.05	antracite anthracite matt	250 V~	16	10	5,41
3651.25.07	grigio lucido grey glossy	250 V~	16	10	5,41
3651.25.09	bianco ghiaccio lucido polar white glossy	250 V~	16	10	5,41
3651.25.10	nero lucido black glossy	250 V~	16	10	9,68
3651.25.24	acciaio inossidabile satinato stainless steel matt	250 V~	16	10	6,49
3651.25.45	nero satinato (per serie "pure") granite black, silk matt, lacquered (for "pure" series)	250 V~	16	10	6,17



Deviatore

Change-over switch



Articolo Item	Colore Colour	Volt	A		€
3656.25.05	antracite anthracite matt	250 V~	16	10	7,82
3656.25.07	grigio lucido grey glossy	250 V~	16	10	7,82
3656.25.09	bianco ghiaccio lucido polar white glossy	250 V~	16	10	7,82
3656.25.24	acciaio inossidabile satinato stainless steel matt, lacquered	250 V~	16	10	9,38
3656.25.45	nero satinato (per serie "pure") granite black, silk matt, lacquered (for "pure" series)	250 V~	16	10	8,91



Pulsante

Push-button



Articolo Item	Colore Colour	Volt	A		€
3671.25.05	antracite anthracite matt	250 V~	10	10	8,87
3671.25.09	bianco ghiaccio lucido polar white glossy	250 V~	10	10	8,87
3671.25.24	acciaio inossidabile satinato stainless steel matt, lacquered	250 V~	10	10	12,40



Doppio pulsante

Series push-button



Articolo Item	Colore Colour	Volt	A		€
3675.25.05	antracite anthracite matt	250 V~	10	10	15,35
3675.25.09	bianco ghiaccio lucido polar white glossy	250 V~	10	10	15,35

Frutti da incasso serie INTEGRO

Built-in modules INTEGRO series



Doppio pulsante per tapparelle

Blind series push-button

Articolo Item	Colore Colour	Volt	A		€
3653.25.05	antracite anthracite matt	250 V~	10	10	15,60
3653.25.07	grigio lucido grey glossy	250 V~	10	10	15,60
3653.25.09	bianco ghiaccio lucido polar white glossy	250 V~	10	10	15,60
3653.25.24	acciaio inossidabile satinato stainless steel matt, lacquered	250 V~	10	10	24,90

Articoli supplementari

Supplementary products

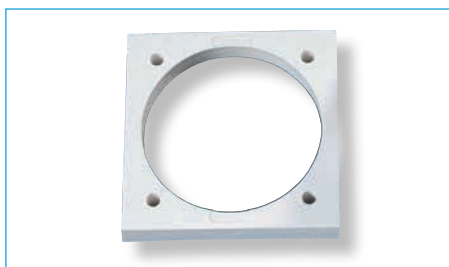

Distanziatore

Surface-mounted spacer ring

Articolo Item	Colore Colour		€
1825.25.15	antracite anthracite glossy	10	1,39
1825.25.06	grigio lucido grey glossy	10	1,39
1825.25.12	bianco ghiaccio lucido polar white glossy	10	1,39
1825.25.24	acciaio inossidabile satinato stainless steel matt, lacquered	10	4,21

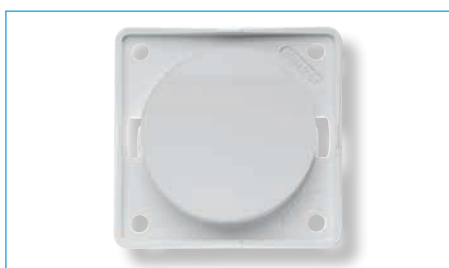

Copriforo

Blank plate

Articolo Item	Colore Colour		€
4516.25.05	antracite anthracite matt	10	2,26
4516.25.07	grigio lucido grey glossy	10	2,26
4516.25.09	bianco ghiaccio lucido polar white glossy	10	2,26
4516.25.24	acciaio inossidabile satinato stainless steel matt, lacquered	10	3,34
4516.25.45	nero satinato granite black, silk matt, lacquered	10	3,17

Frutti da incasso serie INTEGRO

Built-in modules INTEGRO series



Presca SCHUKO
Bipolare con contatti laterali di terra

 Morsetti a vite

SCHUKO socket
Two-pole with side earth contacts

 Screw terminals

Articolo Item	Colore Colour	Volt	A		€
4185.25.05	antracite anthracite matt	250 V~	16	10	3,06
4185.25.06	grigio grey matt	250 V~	16	10	3,06
4185.25.02	bianco ghiaccio polar white matt	250 V~	16	10	3,06

 Con alveoli protetti

 With child protection

Articolo Item	Colore Colour	Volt	A		€
4195.25.05	antracite anthracite matt	250 V~	16	10	4,34
4195.25.06	grigio grey matt	250 V~	16	10	4,34
4195.25.02	bianco ghiaccio polar white matt	250 V~	16	10	4,34



Presca SCHUKO 45°
Bipolare con contatti laterali di terra

 Morsetti a vite

SCHUKO socket 45°
Two-pole with side earth contacts

 Screw terminals

Articolo Item	Colore Colour	Volt	A		€
4185.25.25	antracite anthracite matt	250 V~	16	10	3,06
4185.25.26	grigio grey matt	250 V~	16	10	3,06
4185.25.22	bianco ghiaccio polar white matt	250 V~	16	10	3,06



Presca FRANCO/BELGA
Bipolare con spinotto di terra

 Morsetti a vite

 Con alveoli protetti

FRENCH/BELGIAN socket
Two-pole with earth pin

 Screw terminals

 With child protection

Articolo Item	Colore Colour	Volt	A		€
6195.25.05	antracite anthracite matt	250 V~	16	10	4,90
6195.25.06	grigio grey matt	250 V~	16	10	4,90
6195.25.02	bianco ghiaccio polar white matt	250 V~	16	10	4,90



Presa SVIZZERA

Bipolare con terra - TYP 13

Morsetti a vite

SWISS socket

Two-pole with earth - TYP 13

Screw terminals

Articolo Item	Colore Colour	Volt	A		€
6249.25.05	antracite anthracite matt	250 V~	10	10	17,10
6249.25.06	grigio grey matt	250 V~	10	10	17,10
6249.25.02	bianco ghiaccio polar white matt	250 V~	10	10	17,10

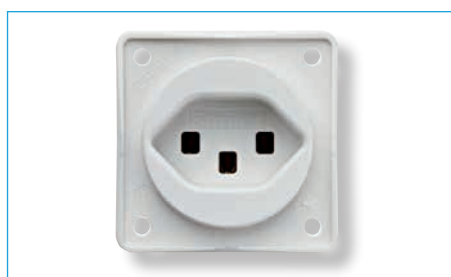

Presa SVIZZERA

Bipolare con terra - TYP 23

Morsetti a vite

SWISS socket

Two-pole with earth - TYP 23

Screw terminals

Articolo Item	Colore Colour	Volt	A		€
6259.25.05	antracite anthracite matt	250 V~	16	10	17,70
6259.25.06	grigio grey matt	250 V~	16	10	17,70
6259.25.02	bianco ghiaccio polar white matt	250 V~	16	10	17,70

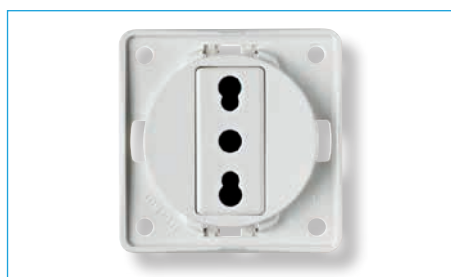

Presa italiana

Bipolare con terra centrale

Morsetti a vite

Con alveoli protetti

Italian socket

Two-pole with central earth

Screw terminals

With child protection

Articolo Item	Colore Colour	Volt	A		€
6251.25.03	nero black matt	250 V~	10/16	10	14,95
6251.25.05	antracite anthracite matt	250 V~	10/16	10	14,95
6251.25.02	bianco ghiaccio polar white matt	250 V~	10/16	10	14,95



Presa INGLESE

Bipolare con terra
BS 1363

Morsetti a vite

Con alveoli protetti

ENGLISH socket

Two-pole with earth
BS 1363

Screw terminals

With child protection

Articolo Item	Colore Colour	Volt	A		€
6262.25.05	antracite anthracite matt	250 V~	13	10	11,25
6262.25.06	grigio grey matt	250 V~	13	10	11,25
6262.25.02	bianco ghiaccio polar white matt	250 V~	13	10	11,25

Frutti da incasso serie INTEGRO

Built-in modules INTEGRO series



Presa USA/CAN NEMA 5-15R
Bipolare con terra

 Morsetti a vite

USA/CAN socket NEMA 5-15R
Two-pole with earth

 Screw terminals

Articolo Item	Colore Colour	Volt	A		€
6263.25.13	nero black matt	125 V~	15	10	12,70
6263.25.02	bianco ghiaccio polar white matt	125 V~	15	10	12,70



Presa AUSTRALIANA
Bipolare con terra

 Morsetti a vite

AUSTRALIAN socket
Two-pole with earth

 Screw terminals

Articolo Item	Colore Colour	Volt	A		€
6258.25.05	antracite anthracite matt	250 V~	10	10	31,55
6258.25.02	bianco ghiaccio polar white matt	250 V~	10	10	31,55



Presa EURO-AMERICANA
adatta come presa rasoio

 Morsetti a vite

 Con alveoli protetti

EURO-AMERICAN socket
suitable as razor socket

 Screw terminals

 With child protection

Articolo Item	Colore Colour	Volt	A		€
6257.25.05	antracite anthracite matt	250 V~	10	10	11,65
6257.25.02	bianco ghiaccio polar white matt	250 V~	10	10	11,65



per spine 6,3x0,8 mm

for 6.3x0.8 mm plugs

Articolo Item	Colore Colour	Volt	A		€
4517.25.05	antracite anthracite matt	12-24 V	max 16	10	15,40
4517.25.09	bianco ghiaccio polar white glossy	12-24 V	max 16	10	15,40



Presa USB (Universal Serial Bus) di potenza

- adatte per ricaricare apparecchi mobili con cavi USB
- protezione contro le sovracorrenti

con 2 ingressi USB di tipo A
 tensione d'ingresso: 100-240 V~ 50/60 Hz
 tensione d'uscita: 5V= (+/- 5%)
 corrente di uscita: 3 A
 consumo (standby) d'ingresso: <50 mW

non adatta per trasmissione dati

USB (Universal Serial Bus) power socket

- suitable to charge mobile appliances with USB cables
- protection against overload

with 2 USB sockets type A
 Input voltage: 100-240 V~ 50/60 Hz
 Output voltage: 5V= (+/- 5%)
 Output current: 3 A
 Cons. (standby) on input: <50 mW

not suitable for data transmission

Articolo Item	Colore Colour		€
2610.25.05	antracite anthracite matt	1	72,50
2610.25.09	bianco ghiaccio polar white matt	1	72,50



Presa USB (Universal Serial Bus) di potenza

- adatte per ricaricare apparecchi mobili con cavi USB
- protezione contro le sovracorrenti

con 1 ingresso USB di tipo A
 tensione d'ingresso: 10-14 V=
 tensione d'uscita: 5V= (+/- 5%)
 corrente di uscita: 1000 mA (max)
 consumo (standby) d'ingresso: <100 mW

non adatta per trasmissione dati

USB (Universal Serial Bus) power socket

- suitable to charge mobile appliances with USB cables
- protection against overload

with 1 USB sockets type A
 Input voltage: 10-14 V=
 Output voltage: 5V= (+/- 5%)
 Output current: 1000 mA (max)
 Cons. (standby) on input: <100 mW

not suitable for data transmission

Articolo Item	Colore Colour		€
2601.25.05	antracite anthracite matt	1	63,05
2601.25.09	bianco ghiaccio polar white glossy	1	63,05

MULTIMEDIA



Presa RCA

- 1 presa per connessione video (gialla)
- 2 prese per connessione audio (rossa/bianca)

RCA Socket

- 1 jack for video connection (yellow)
- 2 jacks for audio connection (red/white)

Articolo Item	Colore Colour		€
4580.25.05	antracite anthracite matt	1	14,45
4580.25.09	bianco ghiaccio polar white matt	1	14,45

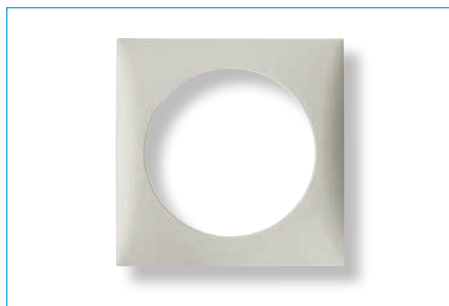

Cornice singola

Single frame

Articolo Item	Colore Colour		€
1827.25.05	antracite anthracite matt	10	0,59
1827.25.07	grigio lucido grey glossy	10	0,59
1827.25.09	bianco ghiaccio lucido polar white glossy	10	0,59
1827.25.10	nero lucido black glossy	10	0,69
1827.25.24	acciaio inossidabile satinato stainless steel matt, lacquered	10	3,62



Cornice con coperchio
adatta per qualunque tipo di presa

Frame with cover
suitable for any type of socket

Articolo Item	Colore Colour		€
1828.25.05	antracite anthracite matt	10	3,14
1828.25.07	grigio lucido grey glossy	10	3,14
1828.25.09	bianco ghiaccio lucido polar white glossy	10	3,14
1828.25.10	nero lucido black glossy	10	3,52
1828.25.24	acciaio inossidabile satinato stainless steel matt, lacquered	10	8,03

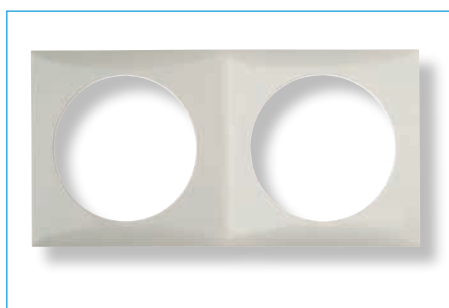

Cornice doppia
per montaggio orizzontale e verticale

Double frame
for horizontal and vertical installation

Articolo Item	Colore Colour		€
1826.25.15	antracite anthracite matt	2	1,68
1826.25.07	grigio lucido grey glossy	2	1,68
1826.25.10	nero lucido black glossy	2	1,78
1826.25.19	bianco ghiaccio lucido polar white glossy	2	1,68
1826.25.24	acciaio inossidabile satinato stainless steel matt, lacquered	2	5,54



Cornice singola IP 44

da utilizzare con guarnizione art. 1853 (diversamente il grado di protezione non potrà essere garantito).

Single IP 44 frame

to be used with sealing strip item 1853 (otherwise protection degree cannot be guarantee).

Articolo Item	Colore Colour		€
1827.25.95	antracite anthracite matt	10	1,00
1827.25.97	grigio lucido grey glossy	10	1,00
1827.25.99	bianco ghiaccio lucido polar white glossy	10	1,00
1827.25.68	acciaio cromo satinato chrome matt, lacquered	10	4,40



Cornice con coperchio IP 44

da utilizzare con guarnizione art. 1853 (diversamente il grado di protezione non potrà essere garantito).

IP 44 frame with cover

to be used with sealing strip item 1853 (otherwise protection degree cannot be guarantee).

Articolo Item	Colore Colour		€
1828.25.95	antracite anthracite matt	10	3,83
1828.25.97	grigio lucido grey glossy	10	3,83
1828.25.99	bianco ghiaccio lucido polar white glossy	10	3,83
1828.25.68	acciaio cromo satinato chrome matt, lacquered	10	8,27

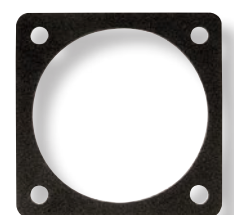

Guarnizione

per rendere stagna IP 44 l'installazione ad incasso delle prese e interruttore con 1 tasto

Sealing strip

to make socket and switch with 1 button built-in installation waterproof IP 44

Articolo Item	Descrizione Description		€
1853	Guarnizione Sealing Strip	10	1,63



Cornice singola

Single frame

Articolo Item	Colore Colour		€
1975.25.45	nero satinato granite black, silk matt, lacquered	10	2,11
1975.25.09	bianco ghiaccio lucido polar white glossy	10	1,45
1975.25.24	acciaio inossidabile satinato stainless steel matt, lacquered	10	6,35

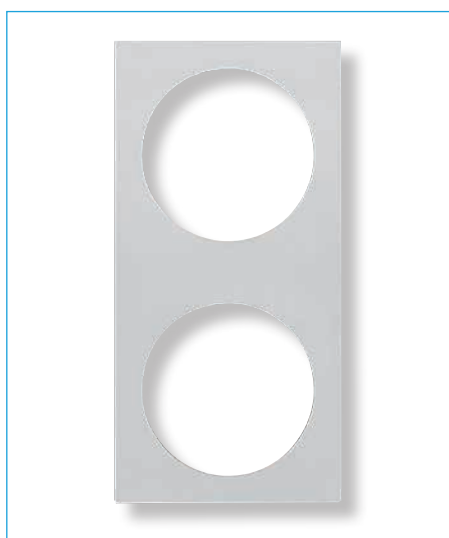

Cornice doppia

per montaggio orizzontale e verticale

Double frame

for horizontal and vertical installation

Articolo Item	Colore Colour		€
1976.25.45	nero satinato granite black, silk matt, lacquered	2	4,18
1976.25.09	bianco ghiaccio lucido polar white glossy	2	3,26
1976.25.24	acciaio inossidabile satinato stainless steel matt, lacquered	2	6,47

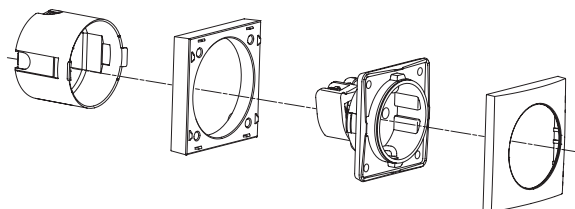

Cornici | Frames

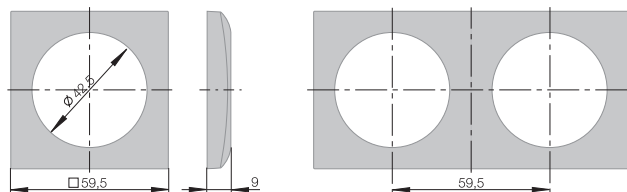

Cuffie di protezione

Protection boxes



Accessori da abbinare ai frutti serie INTEGRO
In termoplastico autoestinguente, secondo le
norme VDE 0606-1

Ø 45 mm
profondità ridotta 22 mm adatta solo per gli
interruttori con fermacavo

Accessories to be matched to the INTEGRO
series modules
In self-extinguishing thermoplastic, in
according to VDE 0606-1

Ø 45 mm
reduced depth 22 mm only suitable for switches
with cable clamp



Articolo Item	Descrizione Description		€
1820.01	profondità ridotta 22 mm, con fermacavo reduced depth 22 mm, with cable clamp	10	1,52



Ø 45 mm
profondità 35,5 mm adatta per prese ed
interruttori

Ø 45 mm
depth 35.5 mm suitable for sockets and switches



Articolo Item	Descrizione Description		€
1820	profondità 35,5 mm, con fermacavo depth 35.5 mm, with cable clamp	10	1,57
1820.02	profondità 35,5 mm, senza fermacavo depth 35.5 mm, without cable clamp	10	1,19

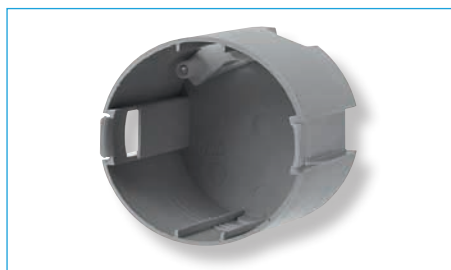

Ø 49 mm
profondità 38 mm, con fermacavo

Ø 49 mm
depth 38 mm, with cable clamp



Articolo Item	Descrizione Description		€
1887	profondità 38 mm, con fermacavo depth 38 mm, with cable clamp	10	2,24



Ø 49 mm
profondità 45,5 mm, con fermacavo

Ø 49 mm
depth 45.5 mm, with cable clamp



Articolo Item	Descrizione Description		€
1883	profondità 45,5 mm, con fermacavo depth 45.5 mm, with cable clamp	10	1,92

Cuffie di protezione

Protection boxes



48 mm x 109 mm

profondità 45,5 mm con doppio fermacavo

48 mm x 109 mm

depth 45.5 mm with double cable clamp

Articolo Item	Descrizione Description		€
1911.01	per montaggio verticale for vertical installation	10	6,02
1912.01	per montaggio orizzontale for horizontal installation	10	6,02

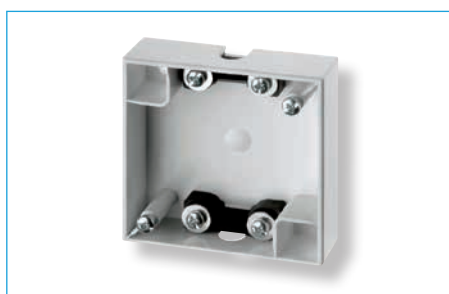

Contenitori da parete

59,5 x 59,5 x 16 mm
adatto per interruttori

Surface-mounted housing

59,5 x 59,5 x 16 mm
suitable for switches

Articolo Item	Colore Colour		€
1152.25.55	antracite anthracite glossy	10	4,42
1152.25.59	bianco ghiaccio polar white glossy	10	4,42



Contenitori da parete

59,5 x 59,5 x 41 mm
adatto per prese

Surface-mounted housing

59,5 x 59,5 x 41 mm
suitable for sockets

Articolo Item	Colore Colour		€
1151.25.05	antracite anthracite glossy	10	7,64
1151.25.07	grigio grey glossy	10	7,64
1151.25.09	bianco ghiaccio polar white glossy	10	7,64

Prese per pannelli

Sockets for panels

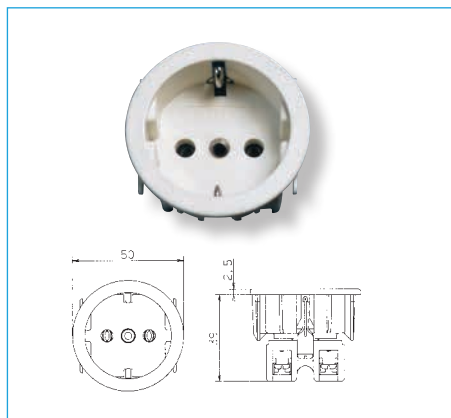

PRESA SCHUKO

10/16 A, 250 V~

Bipolare con contatti laterali di terra.

Fissaggio "SNAP-IN", autobloccante.

Adatta per pannelli di spessore da 0,6-1,5 mm.



Morsetti a vite

SOCKET SCHUKO

10/16 A, 250 V~

Tho-pole with side earth contacts "snap-in"

fixing, self-locking suitable for panels with

0,6-1,5 mm thickness



Screw terminals

Articolo Item	Colore Colour		€
4189.02	bianco white matt	10	3,85
4189.05	nero black matt	10	3,85

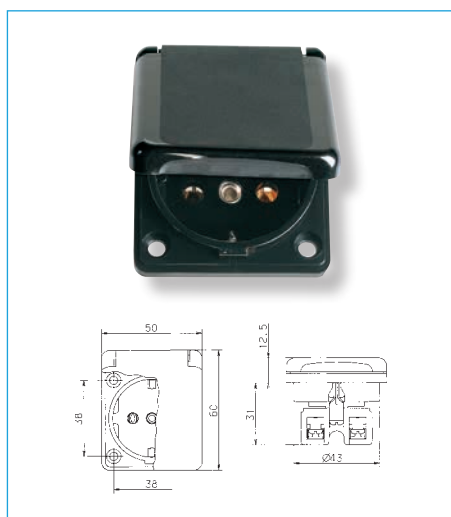

PRESA SCHUKO

10/16 A, 250 V~

Bipolare con contatti laterali di terra.

Coperchio a molla in materiale termoplastico.



Morsetti a vite

SOCKET SCHUKO

10/16 A, 250 V~

Tho-pole with side earth contacts.

Whit hinged cover in thermoplastic



Screw terminals

Articolo Item	Colore Colour		€
08429606	nero black glossy	10	5,59

Cornici singola | Single frame

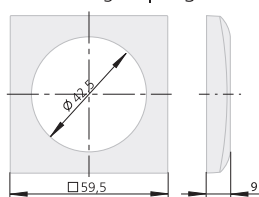

Cornici doppia | Double frame

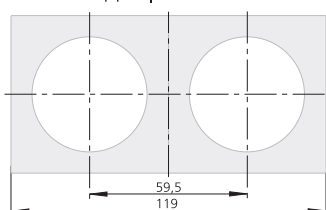

Presa da incasso | Built-in socket

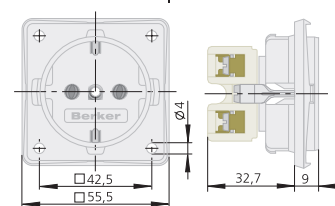

Interruttore/pulsante a bilanciere
Switch/ Push button

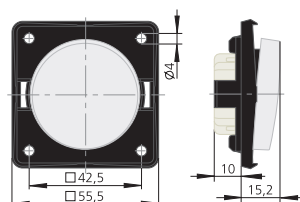

Distanziatore
Spacer ring

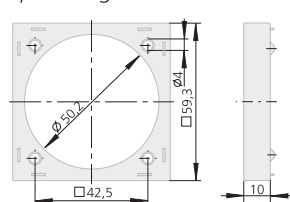

Sistema
System

Profondità d'incasso
Insertion depth

SCHUKO - Tedesco German	32,7 mm
Franco-belga French-Belgian	29,5 mm
Olandese Dutch	29,6 mm
Danese Danish	27,5 mm
Svizzero tipo 13 Switzerland type 13	28,0 mm
USA / Canada NEMA 5-15 R / NEMA 6-20	19,5 mm
Italiano Italian	34,0 mm
Australiana Australian	16,5 mm
Euro-Americana Euro-American	21,3 mm

Taglio di montaggio
Ø 46 mm o Ø 50 mm
a seconda della scatola da incasso
Installation cutout
Ø 46 mm or Ø 50 mm
depending on protection box

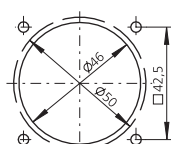

Scatole di protezione contro i contatti | Contact protection boxes

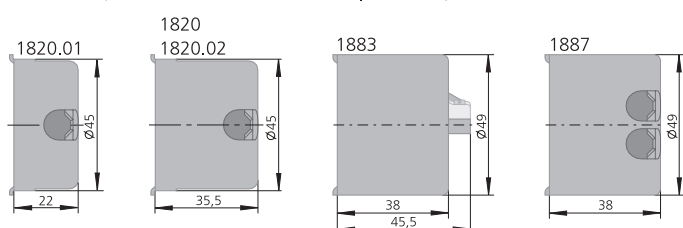

1911.01
1912.02

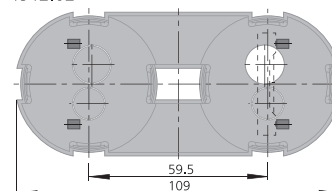

Contenitori da parete
Surface-mounted housing

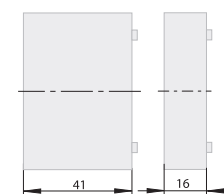

ISTRUZIONI DI MONTAGGIO IP44 | ASSEMBLY INSTRUCTION OF IP44 COVERS

ATTENZIONE! La protezione IP44 è garantita solo se vengono osservate le istruzioni di montaggio.
ATTENTION! Only Upon compliance with the assembly instruction the degree of protection IP44 is guaranteed.

TORCE &
EMERGENZA

*TORCHES &
EMERGENCY*



TOTEM 1

Lampada led professionale multifunzione, ricaricabile. Intenso faro frontale con un ampio fascio diffuso a 150°, per illuminare il luogo di lavoro.

La potente torcia sommitale consente la visione anche a lunghe distanze.

I 2 ganci piroettanti, i 3 potenti magneti: uno sulla base e due sul retro, e il corpo lampada orientabile sino a 180° consentono un'ampia flessibilità d'utilizzo, in qualsiasi ambiente di lavoro.

Il rivestimento "alto impatto" in tecnopolimero garantisce un'elevata resistenza agli agenti meccanici e chimici, mentre la finitura gommata conferisce un piacevole ed ergonomico comfort d'utilizzo.

Equipaggiata di batteria ricaricabile al litio.

Multifunction professional led lamp, rechargeable. Strong frontal flood with 150° wide beam, ideal to light work place.

Powerful top spot, that permits long distance viewing.

The 2 rotating hooks, the 3 strong magnets (1 on the base and 2 on the back), and the 180° swivel body allow a wide flexibility of use, in any work's place.

"High impact" technopolymer coat, that guarantees high resistance to mechanical and chemical agents. Rubber finish that gives pleasant and ergonomic comfort.

Equipped with lithium rechargeable battery.

Caratteristiche tecniche:

- Alimentazione: 5V-1A tramite cavetto USB ed alimentatore 110÷240V ~ forniti in dotazione
- Batteria litio: 3,7V-2200mAh
- Fonte luminosa: led SMD 6500°K - CRI>80
- Autonomia: 9 ore (torcia) - 4 ore (faro)
- Tempo ricarica: 3½ ore
- Grado di protezione: IP54
- Resistente agli urti: IK07
- Temperatura di funzionamento: -10 +40°C
- Colore corpo: giallo e nero

Technical features:

- Power supply: 5V-1A through USB cable and driver 110÷240V~, included
- Lithium battery: 3,7V-2200mAh
- Light source: led SMD 6500°K - CRI>80
- Autonomy: 9 hours (spot) - 4 hours (flood)
- Charging time: 3½ hours
- Protection degree: IP54
- Shockproof: IK07
- Working temperature: -10 +40°C
- Colour: yellow and black



POTENTE TORCIA SOMMITALE
POWERFUL TOP SPOT



180° ORIENTABILE
SWIVEL

IP54



SHOCK PROOF



LITHIUM



9 hours

400 LUMEN



USB

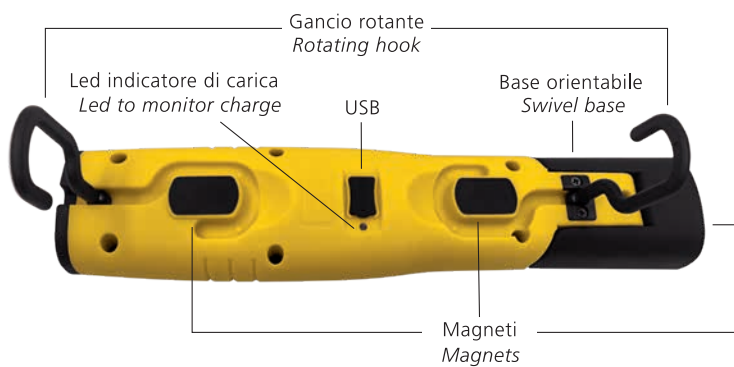

Torcia | Spot
1 LED 3W
120 lm - 32 m

Faro | Flood
7 LED 0,5W
400 lm - 30 m

Selettore faro/torcia
Switch flood/spot



Articolo Item	Batterie Batteries	Flusso Flux	Portata fascio Beam range	Dimensioni Dimensions	Peso Weight		€
*TM1	Litio Lithium	400 lm	32 - 30 m	58 x 225 x 45 mm	310 gr	4	42,60

TOTEM²



Lampada led professionale multifunzione, ricaricabile. Intenso faro frontale con un ampio fascio diffuso a 150° per illuminare il luogo di lavoro.

La potente torcia sommitale consente la visione anche a lunghe distanze.

Il gancio piroettante, i 2 potenti magneti: uno sulla base e uno sul retro, e il corpo lampada orientabile sino a 180° consentono un'ampia flessibilità d'utilizzo, in qualsiasi ambiente di lavoro.

Il rivestimento in tecnopolimero "alto impatto" garantisce un'elevata resistenza agli agenti meccanici e chimici, mentre la finitura gommata conferisce un piacevole ed ergonomico comfort d'utilizzo.

Equipaggiata di batteria ricaricabile al litio.

Multifunction professional led lamp, rechargeable. Strong frontal flood with 150° wide beam, ideal to light work place.

Powerful top spot, that permits long distance viewing.

The rotating hook, the 2 strong magnets (1 on the base and 1 on the back), and the 180° swivel body allow a wide flexibility of use, in any work's place.

"High impact" technopolymer coat, that guarantees high resistance to mechanical and chemical agents. Rubber finish that gives pleasant and ergonomic comfort.

Equipped with lithium rechargeable battery.

Caratteristiche tecniche:

- Alimentazione 5V-1A tramite cavetto USB ed alimentatore 110÷240V ~ forniti in dotazione
- Batteria litio 3,7V-2200mAh
- Fonte luminosa led SMD e C.O.B. 6500°K - CRI>80
- Autonomia 10 ore (torcia) - 3½ ore (faro)
- Tempo ricarica 3½ ore
- Grado di protezione IP54
- Resistente agli urti IK07
- Temperatura di funzionamento -10 +40°C
- Colore corpo giallo e nero

Technical features:

- Power supply 5V-1A through USB cable and driver 110÷240V~, included
- Lithium battery 3,7V-2200mAh
- Light source led SMD and C.O.B. 6500°K - CRI>80
- Autonomy 10 hours (spot) - 3½ hours (flood)
- Charging time 3½ hours
- Protection degree IP54
- Shockproof IK07
- Working temperature -10 +40°C
- Colour yellow and black



POTENTE TORCIA SOMMITALE
POWERFUL TOP SPOT



180° ORIENTABILE
SWIVEL

IP54	SHOCK PROOF	LITHIUM	10 hours
350 LUMEN	USB		

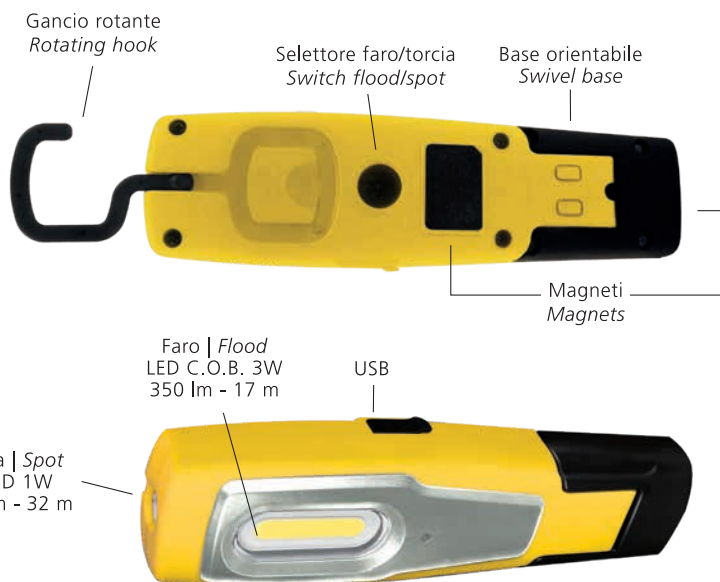

Articolo Item	Batterie Batteries	Flusso Flux	Portata fascio Beam range	Dimensioni Dimensions	Peso Weight	€
*TM2	Litio Lithium	350 lm	32 - 17 m	56 x 190 x 27 mm	250 gr	4 37,90

*I prodotti contraddistinti da asterisco sono in confezione blisterata già pronta per gli espositori di vendita.
*Products marked by an asterisk are in a blister package ready for shop displays.

swing



Lampada led professionale multifunzione. Intenso faro frontale con un ampio fascio diffuso a 150° per illuminare il luogo di lavoro.

La potente torcia sommitale consente la visione anche a lunghe distanze.

Il potente doppio magnete sulla base, il gancio piroettante, la clip estraibile e il corpo lampada orientabile a 360° consentono un'ampia flessibilità d'utilizzo in qualsiasi ambiente di lavoro.

Il rivestimento "alto impatto" in tecnopolimero garantisce un'elevata resistenza agli agenti meccanici e chimici, mentre la finitura gommata conferisce un piacevole ed ergonomico comfort d'utilizzo.

Multifunction professional led lamp.

Strong frontal flood with 150° wide beam, ideal to light work place.

Powerful top spot, that permits long distance viewing.

The double magnet on the base, the rotating hook, the pull-out clip and the 360° swivel body allow a wide flexibility of use, in any work's place.

"High impact" technopolymer coat, that guarantees high resistance to mechanical and chemical agents. Rubber finish that gives pleasant and ergonomic comfort.

Caratteristiche tecniche:

- Alimentazione 3 batterie tipo ministilo (AAA), incluse
- Fonte luminosa led SMD 6500°K - CRI>80
- Autonomia 5 ore (torcia) - 3 ore (faro)
- Grado di protezione IP20
- Resistente agli urti IK07
- Temperatura di funzionamento -10 +40°C
- Colore corpo giallo e nero

Technical features:

- Power supply 3 batteries type AAA, included
- Light source led SMD 6500°K - CRI>80
- Autonomy 5 hours (spot) - 3 hours (flood)
- Protection degree IP20
- Shockproof IK07
- Working temperature -10 +40°C
- Colour yellow and black



POTENTE TORCIA SOMMITALE
POWERFUL TOP SPOT



360° ORIENTABILE
SWIVEL

IP20



SHOCK PROOF



3 AAA



5 hours

200 LUMEN



Torcia | Spot
1 LED 0,5W
100 lm - 26 m

Faro | Flood
5 LED 0,5W
200 lm - 19 m



Gancio rotante estraibile
Pull-out rotating hook

Selettore faro/torcia
Switch flood/spot

Clip estraibile
Pull-out clip

Doppio magnete
Double magnet

Articolo Item	Batterie Batteries	Flusso Flux	Portata fascio Beam range	Dimensioni Dimensions	Peso Weight		€
*SW2	3 el. ministilo (AAA)	200 lm	26 - 19 m	65 x 125 x 25 mm	190 gr	10	12,05



SERIE TYRE

Robuste torce led professionali. Equipaggiate con powerled CREE ad alta emissione. Corpo in ABS rivestito in morbida gomma sintetica con impugnatura antiscivolo ed interruttore sottogomma. Testa antiurto con diffusore a specchio per aumentare la potenza e la focalizzazione del fascio di luce. Resistente alle intemperie, ideale per l'utilizzo all'aperto.

Professional sturdy led torches. Equipped with ultra-bright white powered CREE. ABS body coated in soft thermoplastic rubber, with non-slip hand grip and sealed rubber micro switch. Shockproof head with high diffusion mirror reflector that assures excellent LED light focusing. Weatherproof, ideal for outdoor use.

Caratteristiche tecniche:

- Alimentazione: batterie alcaline
- Fonte luminosa: powerled CREE 6500°K - CRI>80
- Grado di protezione: IP44
- Resistente agli urti: IK05
- Temperatura di funzionamento: -10 +40°C
- Colore corpo: nero

Technical features:

- Power supply: alkaline batteries
- Light source: powered CREE 6500°K - CRI>80
- Protection degree: IP44
- Shockproof: IK05
- Working temperature: -10 +40°C
- Colour: black

IP44



Cinturino anticaduta
Fall arrest strap

Interruttore sottogomma
Sealed rubber switch

Powerled CREE

Impugnatura antiscivolo
Non-slip grip



Articolo Item	Batterie Batteries	Flusso Flux	Portata fascio Beam range	Riflettore Reflector	Dimensioni Dimensions	Peso Weight		€
*2028	2 el. stilo (AA)	70 lm	90 m	Ø 38 mm	Ø 57 x 180 mm	140 gr	6	10,60
*2075	2 el. torcia (D)	100 lm	120 m	Ø 54 mm	Ø 74 x 210 mm	270 gr	6	13,40

LITESTICK^{mini}



Lampada led professionale multifunzione, ricaricabile. Innovativa forma tubolare con un ampio fascio diffuso a 120°, ideale per illuminare il luogo di lavoro.

Stagna all'immersione IP68, e galleggiante, può essere utilizzata direttamente in acqua, o in luoghi umidi. Grazie all'anello posto sulla sommità è possibile sospenderla per garantire un'illuminazione ottimale. Costruita in robusto policarbonato, offre un'elevata resistenza agli agenti meccanici e chimici.

5 differenti funzioni luminose per meglio adattarsi alle necessità d'impiego.

Lunghissima autonomia: fino a 60 ore.

Equipaggiata di batteria al litio ricaricabile tramite cavetto USB fornito in dotazione, è anche in grado di funzionare come power bank, permettendo ricariche di emergenza di piccoli apparecchi (cellulari).

Multifunction professional led lamp, rechargeable. Innovative tubular shape with 120° wide beam, ideal to light work place.

Waterproof IP68, for immersion, and floating, can be use in water and in humid environment.

Thanks to the top ring is possible to hang the lamp for optimal illumination.

Body in sturdy polycarbonate, that guarantees high resistance to mechanical and chemical agents.

5 different light functions, it can be suit to different use need.

Long-lasting autonomy: until 60 hours.

Equipped with lithium battery, rechargeable through USB cable (included), can be also used as power bank, allowing emergency recharge of small appliances (mobile phones).

5 FUNZIONI | 5 FUNCTIONS:

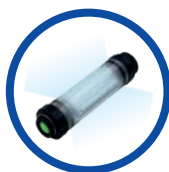

1 Luce bianca 10%
Risparmio energetico
Autonomia: 60 ore

2 Luce bianca 100%
100 lm
Autonomia: 8 ore

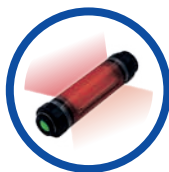

3 Luce rossa
Autonomia: 15 ore

4 Luce rossa intermittente
Autonomia: 31 ore

5 Luce rossa S.O.S.
Autonomia: 31 ore

1 White light 10%
Energy saving
Autonomy: 60 hours

2 White light 100%
100 lm
Autonomy: 8 hours

3 Red light
Autonomy: 15 hours

4 Red light flashing
Autonomy: 31 hours

5 Red light S.O.S.
Autonomy: 31 hours

IP68



SHOCK
PROOF



LITHIUM



FLASH



USB



60 hours

100
LUMEN

Caratteristiche tecniche:

- Alimentazione 5V-1A tramite cavetto USB, fornito in dotazione
- Batteria litio 3,7V-2600mAh
- Fonte luminosa led SMD 6500°K - CRI>70
- Autonomia 60 ore (10% di luce)
8 ore (100% di luce)
- Tempo ricarica 5 ore
- Grado di protezione IP68
- Resistente agli urti IK07
- Temperatura di funzionamento -10 +50°C
- Colore corpo nero

Technical features:

- Power supply 5V-1A through USB cable, included
- Lithium battery 3,7V-2600mAh
- Light source led SMD 6500°K - CRI>70
- Autonomy 60 hours (light 10%)
8 hours (light 100%)
- Charging time 5 hours
- Protection degree IP68
- Shockproof IK07
- Working temperature -10 +50°C
- Colour black



GALLEGGIANTE IP68
FLOATING IP68



DOPPIO INGRESSO:
• Ricarica
• Power bank
Tramite cavetto usb
DOUBLE INPUT:
• Recharge
• Power bank
Through usb cable



INTERRUTTORE
STAGNO E ANELLO DI
SOSPENSIONE
WATERPROOF
SWITCH AND
HANGING RING



LED BLU INDICATORI
DI CARICA
BLUE LEDS TO
MONITOR CHARGE

Articolo Item	Batterie Batteries	Flusso Flux	Dimensioni Dimensions	Peso Weight		€
*Q14	Litio Lithium	100 lm	Ø 36 x 145 mm	127 gr	4	34,05

LITESTICK



Lampada led professionale multifunzione, ricaricabile. Innovativa forma tubolare con un ampio fascio diffuso a 120°, ideale per illuminare il luogo di lavoro. Stagna all'immersione IP68, egalleggiante, può essere utilizzata direttamente in acqua, o in luoghi umidi. Grazie all'anello posto sulla sommità è possibile sospenderla per garantire un'illuminazione ottimale. Costruita in robusto policarbonato, offre un'elevata resistenza agli agenti meccanici e chimici. 3 differenti intensità luminose e la funzione di flashing per meglio adattarsi alle necessità d'impiego. Lunghissima autonomia: fino a 72 ore. Equipaggiata di batteria al litio ricaricabile tramite cavetto USB fornito in dotazione, è anche in grado di funzionare come power bank, permettendo ricariche di emergenza di piccoli apparecchi (cellulari).

Multifunction professional led lamp, rechargeable. Innovative tubular shape with 120° wide beam, ideal to light work place. Waterproof IP68, for immersion, and floating, can be use in water and in humid environment. Thanks to the top ring is possible to hang the lamp for optimal illumination. Body in sturdy polycarbonate, that guarantees high resistance to mechanical and chemical agents. 3 different light intensity, with flashing function, it can be suit to different use need. Long-lasting autonomy: until 72 hours. Equipped with lithium battery, rechargeable through USB cable (included), can be also used as power bank, allowing emergency recharge of small appliances (mobile phones).

4 FUNZIONI | 4 FUNCTIONS:



- 1 Luce bianca 8%
Risparmio energetico
Autonomia: 72 ore
- 2 Luce bianca 100%
350 lm
Autonomia: 5 ore
- 3 Luce bianca 30%
Autonomia: 10 ore
- 4 Luce bianca
intermittente
Autonomia: 20 ore

- 1 White light 8%
Energy saving
Autonomy: 72 hours
- 2 White light 100%
350 lm
Autonomy: 5 hours
- 3 White light 30%
Autonomy: 10 hours
- 4 White light flashing
Autonomy: 20 hours

Caratteristiche tecniche:

- Alimentazione 5V-1A tramite cavetto USB, fornito in dotazione
- Batteria litio 3,7V-5200mAh
- Fonte luminosa led SMD 6500°K - CRI>70
- Autonomia 72 ore (8% di luce)
5 ore (100% di luce)
- Tempo ricarica 4 ore
- Grado di protezione IP68
- Resistente agli urti IK07
- Temperatura di funzionamento -10 +50°C
- Colore corpo nero

Technical features:

- Power supply 5V-1A through USB cable, included
- Lithium battery 3,7V-5200mAh
- Light source led SMD 6500°K - CRI>70
- Autonomy 72 hours (light 8%)
5 hours (light 100%)
- Charging time 4 hours
- Protection degree IP68
- Shockproof IK07
- Working temperature -10 +50°C
- Colour black

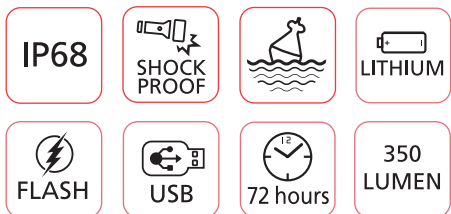

GALLEGGIANTE IP68
FLOATING IP68



DOPPIO INGRESSO:
• Ricarica
• Power bank
Tramite cavetto usb
DOUBLE INPUT:
• Recharge
• Power bank
Through usb cable



INTERRUTTORE
STAGNO E ANELLO DI
SOSPENSIONE
WATERPROOF
SWITCH AND
HANGING RING



LED BLU INDICATORI
DI CARICA
BLUE LEDS TO
MONITOR CHARGE

Articolo Item	Batterie Batteries	Flusso Flux	Dimensioni Dimensions	Peso Weight		€
Q26	Litio Lithium	350 lm	Ø 36 x 265 mm	220 gr	4	52,40



SERIE POWER work

Robuste torçe led professionali in lega d'alluminio di tipo aerospaziale di notevole spessore, colore nero, con impugnatura antiscivolo in morbida gomma sintetica nera.

Equipaggiate con powered CREE ad alta emissione luminosa e parabola a specchio per aumentare la potenza.

Testa con diffusore lenticolare e dispositivo di zoom per consentire la scelta di differenti focalizzazioni di luce da flood (fascio ampio e corto) a spot (fascio stretto e profondo).

Interruttore/selettore sottogomma a 3 funzioni: luce piena, mezza luce, intermittente.

Resistente alle intemperie, ideale per l'utilizzo all'aperto.

Sturdy professional led torches in heavy duty aerospace aluminium alloy, black colour, with anti-slip hand grip in soft black synthetic rubber.

Equipped with powered CREE with high light output and mirror parabola to increase power.

Head with lenticular diffuser and zoom device to allow the choice of different focalization of light from flood (wide and short beam) to spot (narrow and deep beam).

3-functions rubber switch/selector: full light, half light, flashing.

Weatherproof, ideal for outdoor use.

Caratteristiche tecniche:

- Alimentazione: batterie alcaline
- Fonte luminosa: powered CREE 6500°K - CRI>80
- Grado di protezione: IP44
- Resistente agli urti: IK07
- Temperatura di funzionamento: -20 +50°C
- Colore corpo: nero

Technical features:

- Power supply: alkaline batteries
- Light source: powered CREE 6500°K - CRI>80
- Protection degree: IP44
- Shockproof: IK07
- Working temperature: -20 +50°C
- Colour: black

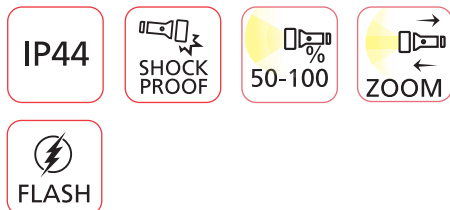

Testa regolabile
Adjustable head
spot/flood

Cinturino anticaduta
Fall arrest strap



Impugnatura antiscivolo
Non-slip grip

Interruttore/selettore sottogomma a 3 funzioni
3 functions sealed rubber switch/selector

Powered CREE

Articolo Item	Batterie Batteries	Flusso Flux	Portata fascio Beam range	Riflettore Reflector	Dimensioni Dimensions	Peso Weight		€
*PW3079	1 el. stilo (AA)	50 lm	55 m	Ø 21 mm	Ø 27 x 103 mm	75 gr	24	9,17
*PW3080	2 el. stilo (AA)	200 lm	65 m	Ø 21 mm	Ø 27 x 153 mm	90 gr	24	10,25
*PW3081	3 el. ministilo (AAA)	300 lm	100 m	Ø 21 mm	Ø 32 x 140 mm	120 gr	24	10,60
*PW3082	3 el. ½ torcia (C)	330 lm	110 m	Ø 25 mm	Ø 34 x 210 mm	175 gr	12	15,25



POWER work-R

Robusta torcia led professionale equipaggiata di batteria ricaricabile al litio.

Corpo in lega d'alluminio di tipo aerospaziale di notevole spessore, colore nero, con impugnatura antiscivolo in morbida gomma sintetica nera.

Intensa fonte luminosa assicurata da powered CREE ad alta emissione luminosa e parabola a specchio per aumentare la potenza.

Testa con diffusore lenticolare e dispositivo di zoom per consentire la scelta di differenti focalizzazioni di luce da flood (fascio ampio e corto), a spot (fascio stretto e profondo).

Interruttore/selettore sottogomma a 3 funzioni: luce piena, mezza luce, intermittente.

Resistente alle intemperie, ideale per l'utilizzo all'aperto.

Sturdy professional led torch equipped with lithium rechargeable battery.

Body in heavy duty aerospace aluminium alloy, black colour, with anti-slip hand grip in soft black synthetic rubber.

Equipped with powered CREE with high light output and mirror parabola to increase power.

Head with lenticular diffuser and zoom device to allow the choice of different focalization of light from flood (wide and short beam) to spot (narrow and deep beam).

3-functions rubber switch/selector: full light, half light, flashing.

Weatherproof, ideal for outdoor use.

Caratteristiche tecniche:

- Alimentazione 5V - 1A tramite cavetto USB
- Batteria litio 2200mAh
- Fonte luminosa powered CREE 6500°K - CRI>80
- Autonomia 4 ore
- Grado di protezione IP44
- Resistente agli urti IK07
- Temperatura di funzionamento -10+40°C
- Colore corpo nero

Technical features:

- Power supply 5V - 1A through USB cable
- Lithium battery 2200 mAh
- Light source powered CREE 6500°K - CRI>80
- Autonomy 4 hours
- Protection degree IP44
- Shockproof IK07
- Working temperature -10 +40°C
- Colour black

IP44

SHOCK PROOF

50-100%

ZOOM

FLASH

USB

LITHIUM

4 hours

250 LUMEN



Articolo Item	Batterie Batteries	Flusso Flux	Portata fascio Beam range	Riflettore Reflector	Dimensioni Dimensions	Peso Weight		€
*PWR5000	Litio Lithium	250 lm	180 m	Ø 27 mm	Ø 36 x 163 mm	214 gr	6	26,00



IP55



SERIE Q-PRO

Innovativa forma quadrata "antirollio". Equipaggiate con powerled CREE ad alta emissione. Robusto corpo in ABS "alto spessore" con impugnatura antiscivolo ed interruttore sottogomma.

Testa gommata dalla particolare forma quadrata per evitare qualsiasi rollio e conferire stabilità alla torcia. Diffusore a specchio per aumentare la potenza e la focalizzazione del fascio di luce. Stagna all'acqua IP55 e galleggiante, per l'utilizzo anche in ambienti particolarmente umidi.

Innovative anti-roll squared shape. Equipped with ultra-bright white powerled CREE. Heavy duty ABS body, with non-slip hand grip and sealed rubber micro switch. Rubber head with special squared shape, anti-roll, that gives stability. Mirror reflector that increase brightness and assures excellent LED light focusing. Waterproof IP55 and floating, for use in extremely humid environment.

Caratteristiche tecniche:

- Alimentazione batterie alcaline
- Fonte luminosa powerled CREE XPE, 6500°K - CRI>80
- Grado di protezione IP55
- Resistente agli urti IK06
- Temperatura di funzionamento -10 +40°C
- Colore corpo giallo e nero

Technical features:

- Power supply alkaline batteries
- Light source powerled CREE XPE, 6500°K - CRI>80
- Protection degree IP55
- Shockproof IK06
- Working temperature -10 +40°C
- Colour yellow and black

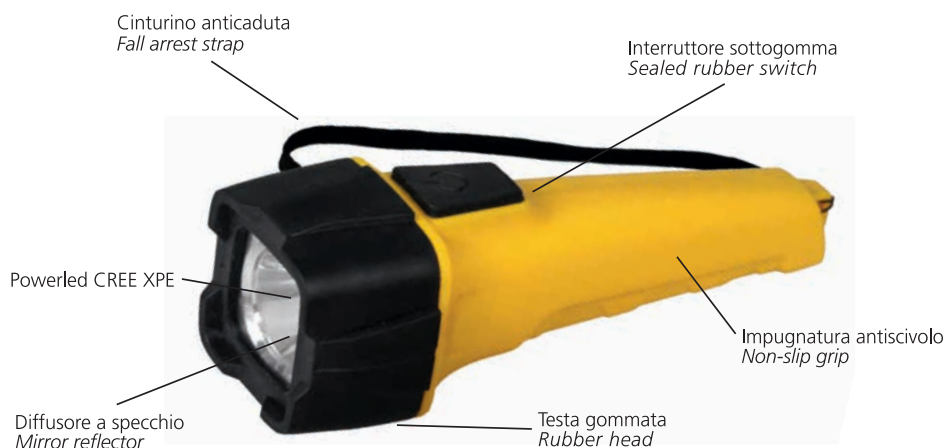

Articolo Item	Batterie Batteries	Flusso Flux	Portata fascio Beam range	Riflettore Reflector	Dimensioni Dimensions	Peso Weight		€
*QP3	2 el. stilo (AA)	90 lm	70 m	Ø 34 mm	58 x 58 x 180 mm	120 gr	6/24	9,53
*QP4	2 el. torcia (D)	120 lm	150 m	Ø 48 mm	79 x 79 x 220 mm	230 gr	6/24	12,40

Lanterna Led galleggiante

Floating Led lantern

LYVIALED

CE



Q-PRO

Innovativa forma quadrata "antirollio". Equipaggiata con powered CREE ad alta emissione. Robusto corpo in ABS "alto spessore" con impugnatura gommata antiscivolo ed interruttore sottogomma.

Base in gomma antisdrucchio e testa gommata dalla particolare forma quadrata per evitare qualsiasi rollio e conferire stabilità alla lanterna. Diffusore a specchio per aumentare la potenza del fascio di luce.

Stagna all'acqua IP55 e galleggiante, per l'utilizzo anche in ambienti particolarmente umidi.

Innovative anti-roll squared shape. Equipped with ultra-bright white powered CREE. Heavy duty ABS body, with non-slip hand grip and sealed rubber micro switch. Base in anti-slip rubber and head with special squared shape, anti-roll, that gives stability. Mirror reflector that increase brightness of light beam. Waterproof IP55 and floating, for use in extremely humid environment.

Caratteristiche tecniche:

- Alimentazione: 4 batterie tipo torcia (D), non incluse
- Fonte luminosa: powered CREE XPE, 6500°K - CRI>80
- Grado di protezione: IP55
- Resistente agli urti: IK06
- Temperatura di funzionamento: -10 +40°C
- Colore corpo: giallo e nero

Technical features:

- Power supply: 4 batteries type D, not included
- Light source: powered CREE XPE, 6500°K - CRI>80
- Protection degree: IP55
- Shockproof: IK06
- Working temperature: -10 +40°C
- Colour: yellow and black

IP55

SHOCK PROOF



160 LUMEN

Impugnatura antiscivolo
Non-slip grip

Interruttore sottogomma
Sealed rubber switch

Testa gommata
Rubber head

Powered CREE XPE

Diffusore a specchio
Mirror reflector



Articolo Item	Batterie Batteries	Flusso Flux	Portata fascio Beam range	Riflettore Reflector	Dimensioni Dimensions	Peso Weight		€
QPT	4 el. torcia (D)	160 lm	180 m	Ø 65 mm	123 x 123 X 193 mm	500 gr	1/6	25,35

Lanterne led di emergenza

Emergency LED lanterns

LYVIALED



MILLENNIUM LED



Lanterna ricaricabile con accensione automatica in caso di black-out.

Corpo in materiale plastico speciale, antiurto, impermeabile.

Parabola ad alta diffusione luminosa.

Interruttore a pulsante sottogomma, impermeabile, antiurto.

Riflettore a specchio Ø 105 mm.

Circuito di protezione sovraccarico e sovrascarica della batteria.

Alimentatore a spina 230V ~ 9V=300mA e adattatore 12V per accendisigari auto.

Cinghia a tracolla.

Rechargeable lantern, with automatic switch-on in case of black-out.

Body in special plastic material, shockproof, waterproof.

High light diffusion parabola.

Sealed rubber push button switch, waterproof, shockproof.

Mirror reflector Ø 105 mm.

Battery over discharge protection circuit.

Plug-in driver 230V - 9 V=300 mA and 12 V car adapter.

Shoulder strap.

Caratteristiche tecniche:

- Alimentazione Batteria Pb ermetica ricaricabile 6V - 4 Ah, estraibile
- Fonte luminosa 1 power led 3 W
- Autonomia 7 ore a luce piena, 12 ore mezza luce
- Tempo ricarica 20 ore
- Grado di protezione IP44
- Resistente agli urti IK06
- Temperatura di funzionamento -10 +40°C
- Colore corpo nero

Technical features:

- Power supply Extractable hermetic rechargeable Pb battery 6 V - 4 Ah
- Light source 1 power led 3 W
- Autonomy 7 hours full light, 12 hours half light
- Charging time 20 hours
- Protection degree IP44
- Shockproof IK06
- Working temperature -10 +40°C
- Colour black

IP44

SHOCK PROOF

50-100

Pb

240 LUMEN

12 hours

Interruttore sottogomma
Sealed rubber switch

1 power LED 3W

Riflettore a specchio
Mirror reflector



Lead to monitor charge
Led indicatore di carica

Jack alimentazione
Jack for power supply



Articolo Item	Batterie Batteries	Flusso Flux	Portata fascio Beam range	Dimensioni Dimensions	Peso Weight		€
GW.2000	Pb	240 lm	300 m	200 x 120 x 150 mm	1180 gr	8/16	57,05



ACCESSORIO

Supporto a parete per la ricarica

ACCESSORY

Wall charging bracket

Articolo Item	Descrizione Description		€
MB.2000	Supporto per ricarica Charging support	1	6,55



RICAMBIO

Adattatore 12 V per ricarica da accendino auto

SPARE PART

12 V Adapter for car charging

Articolo Item	Descrizione Description		€
CG.1000	Cavetto ed adattatore 12 V 12 V cord and adapter	1	11,15



RICAMBIO

Alimentatore 230 V ~ 50 Hz
9 V = 300 mA

SPARE PART

230 V ~ 50 Hz driver
9 V = 300 mA



Articolo Item	Descrizione Description		€
CG.2000LED	Alimentatore 230 V 230 V driver	1	15,85



RICAMBIO

Batteria ermetica al piombo, ricaricabile, 6 V 4 Ah
Adatta per lampade di emergenza portatili

SPARE PART

Hermetic lead acid battery, rechargeable, 6 V 4 Ah
Suitable for portable emergency lamps



Articolo Item	Dimensioni Dimensions		€
HP.0604	98 x 70 x 47 mm	1	17,70

Lanterne led di emergenza

Emergency LED lanterns

LYVIALED



DUAL 6000 LED



Lanterna ispezione portatile, ricaricabile con accensione automatica in caso di black-out. Corpo in materiale plastico speciale, antiurto, impermeabile.

Giunto per permettere l'orientamento della testa da 20° a 90°.

Commutatore a rotazione con le funzioni di: luce led fissa - luce led intermittente - stato della batteria.

Riflettore a specchio Ø 105 mm, protetto da ghiera in robusta gomma vulcanizzata resistente agli urti ed agli olii.

Maniglione ergonomico.

Circuito di protezione sovraccarico e sovrascarica della batteria.

Alimentatore a spina 230V ~ 12V = 500mA e adattatore 12V per accendisigari auto.

Supporto a muro per la ricarica (incluso).

Portable, rechargeable inspection lantern, with automatic switch-on in case of black-out.

Body in special plastic material, shockproof, waterproof.

Swivel joint from 20° to 90°.

Rotating switch with functions: fixed LED light - intermittent LED light - battery status.

Mirror reflector Ø 105 mm, protected by ring nut in sturdy vulcanised shockproof and oil-proof rubber.

Ergonomic handle.

Battery over discharge protection circuit.

Plug-in driver 230 V - 12 V = 500 mA and 12 V car adapter.

Wall charging bracket (included).

Caratteristiche tecniche:

- Alimentazione: Batteria Pb ermetica ricaricabile 6V - 4Ah, estraibile
- Fonte luminosa: 1 power led 3 W
- Autonomia: 5 ore a luce piena, 8 ore con flash
- Tempo ricarica: 15 ore
- Grado di protezione: IP44
- Resistente agli urti: IK06
- Temperatura di funzionamento: -10 +40°C
- Colore corpo: nero

Technical features:

- Power supply: Extractable hermetic rechargeable Pb battery 6 V - 4 Ah
- Light source: 1 power led 3 W
- Autonomy: 5 hours full light, 8 hours with flash
- Charging time: 15 hours
- Protection degree: IP44
- Shockproof: IK06
- Working temperature: -10 +40°C
- Colour: black

IP44

SHOCK PROOF

FLASH

Pb

8 hours

120 LUMEN



Articolo Item	Batterie Batteries	Flusso Flux	Portata fascio Beam range	Dimensioni Dimensions	Peso Weight		€
GW.6000	Pb	120 lm	177 m	280 x 130 x 115 mm	1530 gr	6/12	64,15



RICAMBI

SPARE PARTS

Articolo Item	Descrizione Description		€
CG.1000	Cavetto ed adattatore per ricarica da accendino auto 12 V 12 V cord and adapter for car cigar lighter charging	1	11,15
CG.6000	Alimentatore Driver 230V~50Hz, 9V = 300 mA	1	14,95
HP.0604	Batteria ermetica al piombo, ricaricabile, 6 V 4 Ah Hermetic lead acid battery, rechargeable, 6V 4 Ah	1	17,70

Lanterne led ricaricabili

Rechargeable LED lanterns

LYVIALED



ULTRASpot^{PLUS}



Lanterna d'ispezione portatile, ricaricabile.
Corpo in materiale plastico speciale, antiurto.
Parabola ad alta diffusione luminosa.
Interruttore e jack per alimentazione sottogomma.
Riflettore a specchio Ø 105 mm, protetto da ghiera in robusta gomma sintetica resistente agli urti ed agli agenti chimici/oleosi.
Alimentatore a spina 230V ~ 12V= 300mA e adattatore 12V per accendisigari auto.

Portable, rechargeable inspection lantern.
Body in special shockproof plastic material.
High light diffusion parabola.
Sealed rubber switch and jack for power supply.
Mirror reflector Ø 105 mm, protected by ring nut in sturdy synthetic rubber resistant to chemical and oily agents. Plug-in driver 230V ~ 12V=300 mA, and 12V car adapter.

Caratteristiche tecniche:

- Alimentazione Batteria Pb ermetica ricaricabile 6V - 4Ah, estraibile
- Fonte luminosa 1 power led 3 W
- Autonomia 8 ore con piena carica
- Tempo ricarica 24 ore
- Grado di protezione IP44
- Resistente agli urti IK06
- Temperatura di funzionamento -10 +40°C
- Colore corpo nero

Technical features:

- Power supply Extractable hermetic rechargeable Pb battery 6V - 4 Ah
- Light source 1 power led 3 W
- Autonomy 8 hours with full charge
- Charging time 24 hours
- Protection degree IP44
- Shockproof IK06
- Working temperature -10 +40°C
- Colour black

IP44

SHOCK PROOF

Pb

18 hours

130 LUMEN



Articolo Item	Batterie Batteries	Flusso Flux	Portata fascio Beam range	Dimensioni Dimensions	Peso Weight		€
GW.2003	Pb	130 lm	183 m	Ø 120 x 215 mm	1200 gr	8/16	31,50



RICAMBI

SPARE PARTS

Articolo Item	Descrizione Description		€
CG.1000	Cavetto ed adattatore per ricarica da accendino auto 12 V 12 V cord and adapter for car cigar lighter charging	1	11,15
CG.3000	Alimentatore Driver 230V~50Hz, 9V = 300 mA	1	6,26
HP.0604	Batteria ermetica al piombo, ricaricabile, 6 V 4 Ah Hermetic lead acid battery, rechargeable, 6V 4 Ah	1	17,70

Lampade di emergenza ricaricabili LED

Rechargeable LED emergency lamps

LYVIALED



Starled

25 LED



ALTA LUMINOSITÀ | HIGH BRIGHTNESS

IP40



500 LUMEN

Lanterna portatile ricaricabile, automatica, d'emergenza.

25 LED bianchi ad alta luminosità.

Doppia luce: luce faro e torcia.

Circuito elettronico di accensione automatica in mancanza di tensione di rete.

Completa di cavo di alimentazione incorporato.

LED indicatore di carica.

Circuito di protezione sovraccarico e sovrascarica batteria.

Rechargeable, automatic, emergency portable lantern.

25 white LED, extremely high brightness.

Double function: light flood and spot.

Automatic switch on electronic circuit if mains voltage is down.

Complete with built-in power supply cord.

LED to monitor charge.

Battery overcharge protection circuit.

Caratteristiche tecniche:

- Alimentazione 230V-50Hz
Batteria Pb ermetica ricaricabile 6V - 4Ah
- Fonte luminosa 25 LED bianchi
- Autonomia 8 ore (faro)
30 ore (torcia)
- Tempo ricarica 15 ore
- Grado di protezione IP40
- Resistente agli urti IK05
- Temperatura di funzionamento -10 +40°C
- Colore corpo bianco ghiaccio

Technical features:

- Power supply 230V-50Hz
hermetic rechargeable Pb battery 6 V - 4 Ah
- Light source 25 white led
- Autonomy 8 hours (flood)
30 hours (spot)
- Charging time 15 hours
- Protection degree IP40
- Shockproof IK05
- Working temperature -10 +40°C
- Colour polar white

Selettore faro/spot
Switch flood/spot

Torcia 7 led
Spot 7 led

Faro 18 Led
Flood 18 Led

Led indicatore di carica
Led to monitor charging



Articolo Item	Batterie Batteries	Flusso Flux	Dimensioni Dimensions	Peso Weight		€
DL.1077	Pb	500 lm	270 x 130 x 65 mm	1100 gr	8/16	22,85



RICAMBIO

batteria ermetica al piombo, ricaricabile, 6 V 4 Ah
Adatta per lampade di emergenza portatili

SPARE PART

hermetic lead acid battery, rechargeable, 6 V 4 Ah
Suitable for portable emergency lamps

Articolo Item	Dimensioni Dimensions		€
HP.0604	98 x 70 x 47 mm	1	17,70

Starlight



Lanterna portatile ricaricabile, automatica, d'emergenza.
 24 LED SMD, bianco freddo, ad altissima luminosità.
 Doppia luminosità: luce piena, mezza luce.
 Circuito elettronico di accensione automatica in mancanza di tensione di rete.
 Completa di cavo di alimentazione incorporato.
 LED indicatore di carica.
 Circuito di protezione sovraccarico e sovrascarica batteria.

Rechargeable, automatic, emergency portable lantern.
 24 LED SMD, cold white, extremely high brightness.
 Double function: full light, half light.
 Automatic switch on electronic circuit if mains voltage is down.
 Complete with built-in power supply cord.
 LED to monitor charge.
 Battery overcharge protection circuit.

Caratteristiche tecniche:

- Alimentazione 230V - 50Hz
Batteria Pb ermetica ricaricabile 6V - 4Ah
- Fonte luminosa 24 LED SMD 3,6V - 20mA
- Autonomia 5 ore a luce piena
8 ore con mezza luce
- Tempo ricarica 16 ore
- Grado di protezione IP40
- Resistente agli urti IK05
- Temperatura di funzionamento -10 +40°C
- Colore corpo bianco ghiaccio

Technical features:

- Power supply 230V-50Hz
hermetic rechargeable Pb battery 6 V - 4 Ah
- Light source 24 led SMD 3,6 V - 20 mA
- Autonomy 5 hours full light
8 hours half light
- Charging time 16 hours
- Protection degree IP40
- Shockproof IK05
- Working temperature -10 +40°C
- Colour polar white

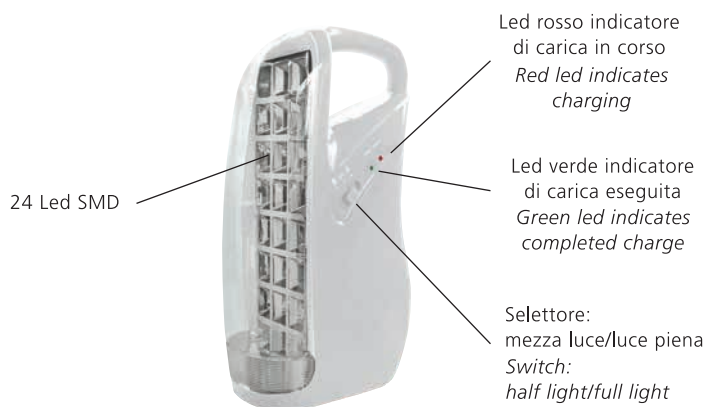

IP40

SHOCK PROOF

50-100%

Pb

8 hours

300 LUMEN

Articolo Item	Batterie Batteries	Flusso Flux	Dimensioni Dimensions	Peso Weight		€
DL.1090	Pb	300 lm	270 x 150 x 83 mm	1150 gr	8/16	27,40



RICAMBIO

batteria ermetica al piombo, ricaricabile, 6 V 4 Ah
 Adatta per lampade di emergenza portatili

SPARE PART

hermetic lead acid battery, rechargeable, 6 V 4 Ah
 Suitable for portable emergency lamps

Articolo Item	Dimensioni Dimensions		€
HP.0604	98 x 70 x 47 mm	1	17,70

Magnetica



Lampada led da lavoro. Intenso faro frontale, led C.O.B., con un ampio fascio a 120° per illuminare il luogo di lavoro.

Il gancio piroettante e il potente magnete sul retro consentono un'ampia flessibilità d'utilizzo in qualsiasi ambiente di lavoro.

Con rivestimento in ABS gommato e impugnatura ergonomica antiscivolo.

Led working lamp.

Intense flood, led C.O.B., with a 120° wide beam to illuminate the work place.

The pivoting hook and the powerful magnet on the back allow a wide flexibility of use in any work place. With rubber ABS coating and ergonomic anti-slip hand grip.

Caratteristiche tecniche:

- Alimentazione 3 batterie tipo stilo (AA), non incluse
- Fonte luminosa led C.O.B. 3W
- Grado di protezione IP20
- Resistente agli urti IK03
- Temperatura di funzionamento 0 +40°C
- Colore corpo arancione e nero

Technical features:

- Power supply 3 batteries type AA, not included
- Light source led C.O.B. 3W
- Protection degree IP20
- Shockproof IK03
- Working temperature 0 +40°C
- Colour orange and black

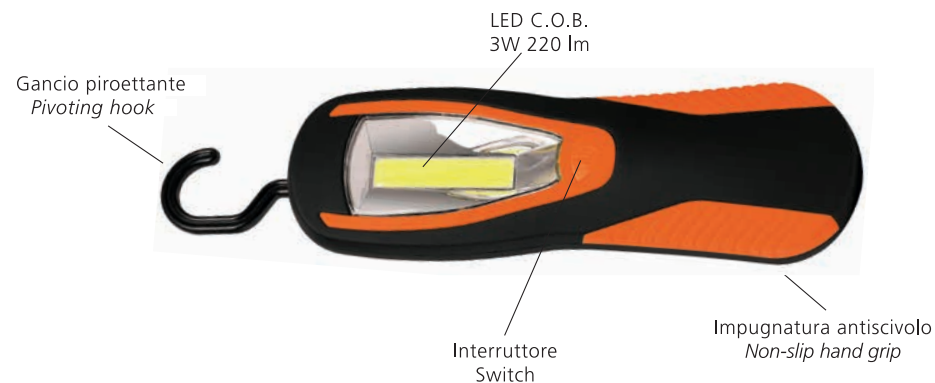

**POTENTE
MAGNETE
POWERFUL
MAGNET**

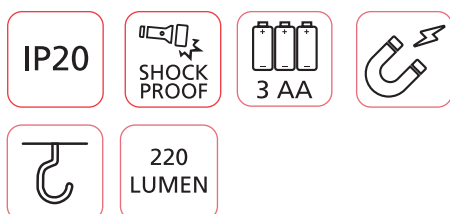

Articolo Item	Batterie Batteries	Flusso Flux	Dimensioni Dimensions	Peso Weight		€
*907	3 el. stilo (AA)	220 lm	200 x 60 x 30 mm	140 gr	12	5,34

CLAMPY

Lampada led multifunzione equipaggiata con intenso faro frontale led C.O.B. con un ampio fascio a 120° e potente torcia led sommitale.

Lampada orientabile sino a 180° e dotata di gancio piroettante sulla testa, di 2 potenti calamite e una pinza sulla base, che consentono un'ampia flessibilità d'utilizzo in qualsiasi ambiente di lavoro. Rivestimento in ABS con finitura "soft-touch".

Multifunction led lamp equipped with an intense LED C.O.B. with a 120° wide beam flood and powerful led spot.

180° swivel lamp, equipped with 1 pivoting hook on the head, 2 powerful magnets and 1 clamp on the base, that allow a wide flexibility of use in any work place.

ABS coating with "soft-touch" finish.

Caratteristiche tecniche:

- Alimentazione 3 batterie tipo ministilo (AAA), non incluse
- Fonte luminosa led C.O.B. 3W e led SMD
- Grado di protezione IP20
- Resistente agli urti IK04
- Temperatura di funzionamento 0 +35°C
- Colore corpo arancione e nero

Technical features:

- Power supply 3 batteries type AAA, not included
- Light source C.O.B. 3W and SMD LEDs
- Protection degree IP20
- Shockproof IK04
- Working temperature 0 +35°C
- Colour orange and black



2 POTENTI MAGNETI
2 POWERFUL MAGNETS



PINZA
CLAMP



180°
ORIENTABILE
SWIVEL



Articolo Item	Batterie Batteries	Flusso Flux	Portata fascio Beam range	Dimensioni Dimensions	Peso Weight		€
*693	3 el. ministilo (AAA)	220 lm	50 m	220 x 45 x 42 mm	140 gr	10	10,70

PIVOT



Lampada led per ispezione.
Intenso faro frontale, led C.O.B., con un ampio fascio a 120°.

Corpo lampada orientabile sino a 180°.

Il gancio piroettante e la potente calamita sulla base consentono un'ampia flessibilità d'utilizzo in qualsiasi ambiente di lavoro.

Rivestimento in ABS con finitura "soft-touch".

Led lamp for inspection.

Intense LED C.O.B. with a 120° wide beam flood.

180° swivel lamp body.

1 pivoting hook, and 1 powerful magnet on the base allow a wide flexibility of use in any work place.

ABS coating with "soft-touch" finish.

Caratteristiche tecniche:

- Alimentazione 3 batterie tipo ministilo (AAA) non incluse
- Fonte luminosa led C.O.B. 3 W
- Grado di protezione IP20
- Resistente agli urti IK03
- Temperatura di funzionamento 0 +40°C
- Colore corpo arancione e nero

Technical features:

- Power supply 3 batteries type AAA, not included
- Light source led C.O.B. 3W
- Protection degree IP20
- Shockproof IK03
- Working temperature 0 +40°C
- Colour orange and black



GANCIO ROTANTE
ROTATING HOOK



180°
ORIENTABILE
SWIVEL

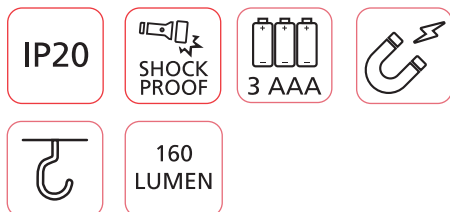

Articolo Item	Batterie Batteries	Flusso Flux	Dimensioni Dimensions	Peso Weight		€
*623	3 el. ministilo (AAA)	160 lm	145 x 60 x 33 mm	120 gr	12	6,68



SERIE GRIP

Torçe led con corpo in ABS e gomma sintetica bicomponente; antiurto, con sagoma antirollio ed impugnatura antiscivolo.

Dotate di pratico cinturino anticaduta.

Equipaggiata con top led bianco ad alta diffusione luminosa.

Led torches with body in ABS and two-component synthetic rubber; shockproof, with anti-roll shape and non-slip hand grip.

Equipped with practical fall arrest strap.

Equipped with high light diffusion white top LED.

Caratteristiche tecniche:

- Alimentazione batterie alcaline
- Fonte luminosa 1 led bianco
- Grado di protezione IP44
- Resistente agli urti IK07
- Temperatura di funzionamento -20 +50°C
- Colore corpo arancione e nero

Technical features:

- Power supply alkaline batteries
- Light source 1 white LED
- Protection degree IP44
- Shockproof IK07
- Working temperature -20 +50°C
- Colour orange and black

IP44



Cinturino anticaduta
Fall arrest strap

Top led



Testa in gomma antirollio
Anti-roll rubber head

Impugnatura antiscivolo
Non-slip hand grip

Interruttore sottogomma
Sealed rubber switch

Articolo Item	Batterie Batteries	Flusso Flux	Portata fascio Beam range	Riflettore Reflector	Dimensioni Dimensions	Peso Weight		€
*836	2 el. stilo (AA)	70 lm	100 m	Ø 28 mm	Ø 45 x 160 mm	80 gr	12	6,65
*839	2 el. torcia (D)	100 lm	160 m	Ø 45 mm	Ø 70 x 205 mm	200 gr	6	9,17



SERIE Easy

Torce led costruite in materiale plastico antiurto ed impermeabile.
Dotate di pratico cinturino anticaduta.

*Led torches made in shockproof and waterproof plastic material.
Equipped with fall arrest strap.*

Caratteristiche tecniche:

- Alimentazione batterie alcaline
- Fonte luminosa Top led
- Grado di protezione IP44
- Resistente agli urti IK06
- Temperatura di funzionamento -20 +50°C
- Colore corpo arancione e nero

Technical features:

- Power supply alkaline batteries
- Light source Top led
- Protection degree IP44
- Shockproof IK06
- Working temperature -20 +50°C
- Colour orange and black

IP44



Articolo Item	Batterie Batteries	Flusso Flux	Portata fascio Beam range	Riflettore Reflector	Dimensioni Dimensions	Peso Weight		€
*391	2 el. stilo (AA)	40 lm	70 m	Ø 25 mm	Ø 35 x 150 mm	50 gr	12/144	3,42
*392	3 el. stilo (AA)	70 lm	90 m	Ø 35 mm	Ø 47 x 177 mm	80 gr	12/96	5,22



Easy

Lanterna led costruita in materiale plastico antiurto. Stagna all'immersione IP56, e galleggiante, può essere utilizzata direttamente in acqua, o in luoghi umidi.

Riflettore a specchio per aumentare la diffusione luminosa.

Equipaggiata con top led bianco ad alta diffrazione luminosa.

Led lantern made in shockproof plastic material. Waterproof IP56 and floating, for use directly in water or in moist places.

Mirror reflector to increase luminous diffusion. Equipped with high diffusion white top led.

Caratteristiche tecniche:

- Alimentazione 4 batterie tipo torcia (D), non incluse
- Fonte luminosa Top led
- Grado di protezione IP56
- Resistente agli urti IK06
- Temperatura di funzionamento -10 +40°C
- Colore corpo giallo e nero

Technical features:

- Power supply 4 batteries type D, not included
- Light source Top led
- Protection degree IP56
- Shockproof IK06
- Working temperature -10 +40°C
- Colour yellow and black



200 LUMEN



Articolo Item	Batterie Batteries	Flusso Flux	Portata fascio Beam range	Riflettore Reflector	Dimensioni Dimensions	Peso Weight		€
393	4 el. torcia (D)	200 lm	110 m	Ø 95 mm	Ø 120 x 185 mm	310 gr	6/24	11,55

MINE



3 FUNZIONI:



SPOT
150 lm
20 m



FLOOD
90 lm
10 m



FLASH

IP20



SHOCK PROOF



FLASH



3 AAA

150 LUMEN

Lampada da testa con tripla fascia elastica regolabile. Corpo in ABS resistente agli urti, orientabile sull'asse orizzontale.

Doppia fonte luminosa: top led per luce spot, led C.O.B. per luce flood.

Selettore a pulsante con 3 funzioni:

- SPOT
- FLOOD
- FLASH

Caratteristiche tecniche:

- Alimentazione 3 batterie tipo ministilo (AAA), non incluse
- Fonte luminosa Top led e led C.O.B.
- Grado di protezione IP20
- Resistente agli urti IK03
- Temperatura di funzionamento 0 +40°C
- Colore corpo arancione e nero

Head lamp with adjustable triple elastic strap. Body in shockproof ABS, adjustable on horizontal axis.

Double light source: top led for spot light, C.O.B. led for flood light.

Push button switch for 3 functions:

- SPOT
- FLOOD
- FLASH

Technical features:

- Power supply 3 batteries type AAA, not included
- Light source Top led and led C.O.B.
- Protection degree IP20
- Shockproof IK03
- Working temperature 0 +40°C
- Colour orange and black



Articolo Item	Batterie Batteries	Flusso Flux	Portata fascio Beam range	Riflettore Reflector	Dimensioni Dimensions	Peso Weight		€
*3282	3 el. ministilo (AAA)	150 lm	20 m	Ø 40 mm	60 x 41 x 50 mm	95 gr	10/40	6,48

LED 18



4 FUNZIONI | 4 FUNCTIONS:



2 LED



10 LED



18 LED



2 LED
INTERMITTENTI
FLASHING

IP44



SHOCK
PROOF



FLASH



3 AAA



80 hours

72
LUMEN

Lampada da testa con tripla fascia elastica regolabile. Corpo in ABS resistente agli urti, all'umidità ed alle intemperie; orientabile sull'asse orizzontale. 18 LED bianchi di alta luminosità e di lunga durata (100.000 ore). 2 LED rossi di segnalazione. Riflettore ad alta diffusione Ø 35 mm con anello paracolpi. Selettore a pulsante con 4 funzioni:

- 2 LED
- 10 LED
- 18 LED
- 2 LED rossi intermittenti

Caratteristiche tecniche:

- Alimentazione 3 batterie tipo ministilo (AAA), non incluse
- Fonte luminosa 18 LED bianchi
- Autonomia 80 ore (2 led rossi)
70 ore (2 led bianchi)
30 ore (10 led bianchi)
15 ore (18 led bianchi)
- Grado di protezione IP44
- Resistente agli urti IK03
- Temperatura di funzionamento -10 +40°C
- Colore corpo argento e nero

Head lamp with triple adjustable triple elastic strap. Body in shock-proof, humidity-proof and weather-proof ABS; adjustable on horizontal axis. 18 high-brightness and long-life white LEDs (100,000 hours). 2 red signalling LEDs. High diffusion reflector Ø 35 mm with buffer ring. Button selector with 4 flashing:

- 2 LEDs
- 10 LEDs
- 18 LEDs
- 2 red LEDs flashing

Technical features:

- Power supply 3 batteries type AAA, not included
- Light source 18 white leds
- Autonomy 80 hours (2 red leds)
70 hours (2 white leds)
30 hours (10 white leds)
15 hours (18 white leds)
- Protection degree IP44
- Shockproof IK03
- Working temperature -10 +40°C
- Colour silver and black



Articolo Item	Batterie Batteries	Flusso Flux	Riflettore Reflector	Dimensioni Dimensions	Peso Weight		€
*3281	3 el. ministilo (AAA)	72 lm	Ø 35 mm	70 x 65 x 50 mm	90 gr	12/96	7,71



SERIE **BLUPower**

Torçe con corpo in ABS e rivestite in morbida gomma sintetica.

Impugnatura antiscivolo grazie al particolare disegno. Testa antiurto con riflettore ad alta diffusione che permette un'ottima focalizzazione della luce Led.

Equipaggiate con POWERled bianchi ultraluminosi. Microinterruttore sottogomma.

Resistenti alle intemperie.

Torches with ABS body and coated in soft synthetic rubber.

Non-slip hand grip thanks to the special design. Shockproof head with high diffusion reflector that assures excellent LED light focusing.

Equipped with new ultra-bright white POWERLEDs. Sealed rubber micro switch.

Weatherproof.

Caratteristiche tecniche:

- Alimentazione 3 batterie tipo stilo (AA), non incluse
- Fonte luminosa 1 POWERled bianco 1 W
- Grado di protezione IP44
- Resistente agli urti IK04
- Temperatura di funzionamento -10 +40°C
- Colore corpo blu

Technical features:

- Power supply 3 batteries type AA, not included
- Light source 1 ultra-bright white POWERLED
- Protection degree IP44
- Shockproof IK04
- Working temperature -10 +40°C
- Colour blue

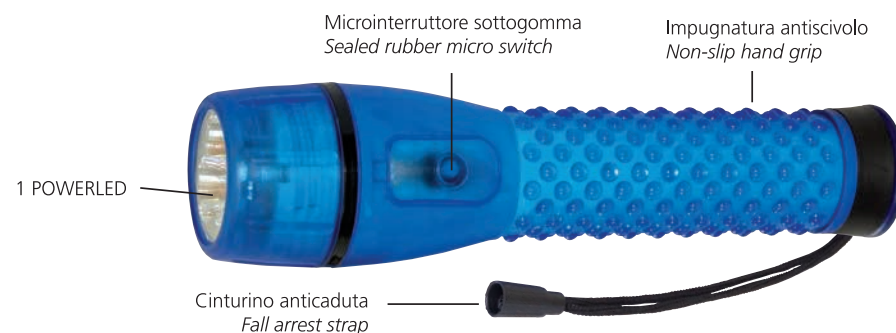

Articolo Item	Batterie Batteries	Flusso Flux	Riflettore Reflector	Dimensioni Dimensions	Peso Weight		€
*967	3 el. stilo (AA)	60 lm	Ø 28 mm	Ø 36 x 208 mm	90 gr	12	4,92

ZOOM LED



Torcia led con corpo in alluminio ad alta resistenza. Resistente agli urti ed alle intemperie.
Zoom: da 1x a 2000x - per miscelare a piacimento l'ampiezza e la lunghezza del fascio luminoso.
Dotata di lente per focalizzare il fascio di luce.
Corpo in alluminio antiscivolo, antiurto.
Anello luminoso per funzione lampeggio d'emergenza.
Pulsante accensione/selezione funzioni.
Cinturino anticaduta.

*Led torch with high resistance aluminium body. Shockproof and weatherproof.
Zoom: from 1x to 2000x - to adjust width and length of the light beam.
Fitted with lens to focus the light beam.
Non-slip aluminium body, shockproof.
Light ring for emergency flashing function.
Switch on/function selector button.
Fall arrest strap.*

Caratteristiche tecniche:

- Alimentazione 3 batterie tipo ministilo (AAA), non incluse
- Fonte luminosa 1 POWERled bianco 1 W
- Grado di protezione IP44
- Resistente agli urti IK03
- Temperatura di funzionamento -10 +40°C
- Colore corpo nero

Technical features:

- Power supply 3 batteries type AAA, not included
- Light source 1 white POWERLED 1W
- Protection degree IP44
- Shockproof IK03
- Working temperature -10 +40°C
- Colour black

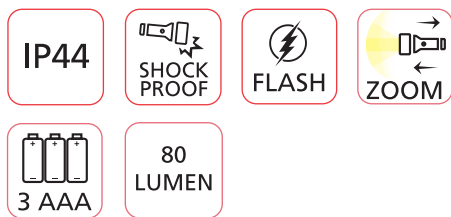

Articolo Item	Batterie Batteries	Flusso Flux	Riflettore Reflector	Dimensioni Dimensions	Peso Weight		€
*7957	3 el. ministilo (AAA)	80 lm	Ø 25 mm	Ø 33 x 112 mm	80 gr	12/48	7,78

Espositore da banco pronto per l'uso e completo di 10 torce art. 7957 | Counter display ready for use and complete with 10 torches item 7957

Articolo Item	Descrizione Description		€
EXT.7957	Espositore 10 torce 10 torches display	1	77,80

GUMMY LED



Torce led con corpo in ABS, rivestite in gomma sintetica colorata.
Equipaggiata con 9 top led bianchi ad alta luminosità.
Interruttore a pulsante sottogomma.
Con cinturino anticaduta.
Resistenti alle intemperie IP44.

Confezionate in espositore da banco pronto per l'uso e composto da:
 • 6 pz. colore nero
 • 6 pz. colore blu
 • 6 pz. colore giallo
 • 6 pz. colore rosso

N.B. confezione minima di vendita 24pz.
I colori non sono selezionabili.

Caratteristiche tecniche:

- Alimentazione 3 batterie tipo ministilo (AAA), non incluse
- Fonte luminosa 9 led bianchi
- Grado di protezione IP44
- Resistente agli urti IK03
- Temperatura di funzionamento 0 +40°C

LED torches with ABS body coated in synthetic coloured rubber.
Equipped with 9 white high-brightness LEDs.
Sealed rubber pushbutton switch.
With fall arrest strap.
Weatherproof IP44.

Packaged in counter display ready for use and consisting of:
 • 6 pcs. black colour
 • 6 pcs. blue colour
 • 6 pcs. yellow colour
 • 6 pcs. red colour

Note: Minimum selling package 24 pcs.
The colours cannot be chosen.

Technical features:

- Power supply 3 batteries type AAA, not included
- Light source 9 white leds
- Protection degree IP44
- Shockproof IK03
- Working temperature 0 +40°C



IP44 SHOCK PROOF 3 AAA 15.000 mcd

Articolo Item	Batterie Batteries	Flusso Flux	Riflettore Reflector	Dimensioni Dimensions	Peso Weight		€
9788	3 el. ministilo (AAA)	15.000 mcd	Ø 21 mm	Ø 32 x 97 mm	30 gr	24/144	3,03

Mini TORCIA LED



Leggera e maneggevole.
Corpo in alluminio aerospaziale T6061.
Equipaggiata con 1 led bianco da 0,5W ad alta luminosità.
Lente in policarbonato riflettente.
Resistente alla pioggia.
Con cinturino portachiavi.

*Light and handy.
T6061 Aerospace aluminium body.
Equipped with 0.5W high brightness white LED.
Lens in reflecting polycarbonate.
Rainproof.
With key strap.*

Confezionate in espositore da banco pronto per l'uso e composto da:

- 5 pz. colore nero
- 5 pz. colore rosso
- 5 pz. colore blu
- 5 pz. colore argento
- 5 pz. colore verde

Packaged in counter display ready for use and consisting of:

- 5 pcs. black colour
- 5 pcs. red colour
- 5 pcs. blue colour
- 5 pcs. silver colour
- 5 pcs. green colour

N.B. confezione minima di vendita 25 pz.
I colori non sono selezionabili.

*Note: Minimum selling package 25 pcs.
The colours cannot be chosen.*

Caratteristiche tecniche:

- Alimentazione 1 batteria tipo stilo (AA), non inclusa
- Fonte luminosa 1 led bianco 0,5 W
- Grado di protezione IP44
- Resistente agli urti IK03
- Temperatura di funzionamento -10 +40°C

Technical features:

- Power supply 1 batteries type AA, not included
- Light source 1 white led 0,5W
- Protection degree IP44
- Shockproof IK03
- Working temperature -10 +40°C



IP44	SHOCK PROOF	1 AA	12 LUMEN
------	-------------	------	----------

Articolo Item	Batterie Batteries	Flusso Flux	Riflettore Reflector	Dimensioni Dimensions	Peso Weight	€
3073	1 el. stilo (AA)	12 lm	Ø 15 mm	Ø 20 x 95 mm	30 gr	25/100 5,27

ASTUCCIO LED

Astuccio compatto, leggero e maneggevole; ideale per borsetta, borsello, marsupio. Equipaggiato con led C.O.B. frontale ultraluminoso e 2 led sommitali. Dotato di gancio portachiavi. Confezionato in pratico espositore da banco.

Compact, light and handy case; ideal for hand bag, purse, belt bag. Equipped with high brightness frontal C.O.B. led and 2 top leds. With key hook. Packaged in counter display.

Caratteristiche tecniche:

- Alimentazione: 2 batterie tipo ministilo (AAA), non incluse
- Fonte luminosa: 1 led C.O.B. frontale + 2 led sommitali
- Grado di protezione: IP20
- Resistente agli urti: IK03
- Temperatura di funzionamento: 0 +40°C
- Colore corpo: blu

Technical features:

- Power supply: 2 batteries type AAA, not included
- Light source: 1 frontal C.O.B. led + 2 top leds
- Protection degree: IP20
- Shockproof: IK03
- Working temperature: 0 +40°C
- Colour: blue

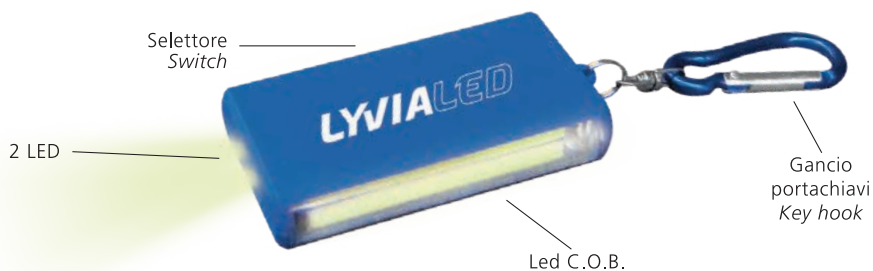

IP20

SHOCK
PROOF

2 AAA

120
LUMEN

Articolo Item	Batterie Batteries	Flusso Flux	Dimensioni Dimensions	Peso Weight		€
3938	2 el. ministilo (AAA)	120 lm	70 x 40 x 15 mm	30 gr	24/144	2,88

FLUO



Astuccio led per ispezione leggero e maneggevole. Dotato di 24 LED frontali + 4 LED sommitali bianchi ad altissima luminosità. Con riflettore a specchio. Il gancio piroettante e la calamita sul retro consentono un'ampia flessibilità d'utilizzo. Costruito in tecnopolimero con finitura nera satinata ed inserto in vivaci colori: verde, giallo, arancione.

Confezionati in espositore da banco pronto per l'uso e composto da:

- 4 pz. colore verde
- 4 pz. colore arancione
- 4 pz. colore giallo

N.B. confezione minima di vendita 12 pz. I colori non sono selezionabili.

Caratteristiche tecniche:

- Alimentazione 3 batterie tipo minitilo (AAA), non incluse
- Fonte luminosa Top led
- Grado di protezione IP20
- Resistente agli urti IK03
- Temperatura di funzionamento -10 +40°C

Led case for inspection, light and handy. Equipped with 24 front LEDs + 4 side extra high brightness white LEDs. With mirror reflector. At the rear it is fitted with magnet and rotating hook, that allow a wide flexibility of use. Made in techno-polymer with black satin finish and bright-colour insert: green, yellow, orange.

Packaged in counter display ready for use and consisting of:

- 4 pcs. green colour
- 4 pcs. orange colour
- 4 pcs. yellow colour

Note: Minimum selling package 12 pcs. The colours cannot be chosen.

Technical features:

- Power supply 3 elements R03 (AAA), not included
- Light source Top led
- Protection degree IP20
- Shockproof IK03
- Working temperature -10 +40°C

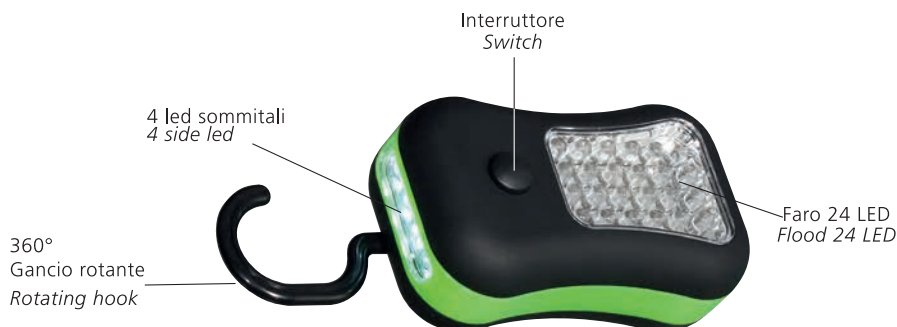

IP20	SHOCK PROOF	3 AAA	63 LUMEN

Articolo Item	Batterie Batteries	Flusso Flux	Dimensioni Dimensions	Peso Weight		€
9072	3 el. minitilo (AAA)	63 lm	95 x 58 x 37 mm	70 gr	12	3,67



Penna tascabile Led

Tradizionale penna tascabile led, con corpo in alluminio robusto, ma estremamente leggero. Fascio luminoso concentrato fornito da 1 led bianco ultraluminoso. Dotata di clip metallica per aggancio. Pulsante sottogomma.

*Traditional pocket led pen, with body in sturdy aluminium, extremely light
1 ultra-bright white led, that assured a focused light beam.
With metallic clip for hook.
Sealed rubber switch.*

Caratteristiche tecniche:

- Alimentazione 2 batterie tipo ministilo (AAA), non incluse
- Fonte luminosa 1 led bianco
- Grado di protezione IP20
- Resistente agli urti IK03
- Temperatura di funzionamento 0 +40°C
- Colore corpo nero

Technical features:

- Power supply 2 batteries type AAA, not included
- Light source 1 white led
- Protection degree IP20
- Shockproof IK03
- Working temperature 0 +40°C
- Colour black

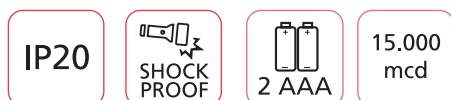

Articolo Item	Batterie Batteries	Flusso Flux	Riflettore Reflector	Dimensioni Dimensions	Peso Weight		€
* 989L	2 el. ministilo (AAA)	15.000 mcd	Ø 10 mm	Ø 13 x 135 mm	30 gr	24	2,95

Lampade leggilibro Led

Book reader Led lamps

LYVIALED



leggilibro

Lampada leggilibro led con braccio flessibile e clip di aggancio.
Diffusore prismatico.

Led book reader lamp with flexible arm and clip for hook
Prismatic diffuser.

Caratteristiche tecniche:

- Alimentazione: 2 batterie tipo CR2016, incluse
- Fonte luminosa: 1 led bianco
- Grado di protezione: IP20
- Resistente agli urti: IK03
- Temperatura di funzionamento: 0 +40°C
- Colore corpo: argento e nero

Technical features:

- Power supply: 2 batteries type CR2016, included
- Light source: 1 white led
- Protection degree: IP20
- Shockproof: IK03
- Working temperature: 0 +40°C
- Colour: silver and black



Articolo Item	Descrizione Description	Batterie Batteries	Flusso Flux	Peso Weight		€
*DX.400	Leggilibro led Led book reader	2 el. CR2016	15.000 mcd	33 gr	24	3,21



leggilibro USB

Lampada leggilibro led USB, indispensabile per illuminare la tastiera del laptop, per l'utilizzo in auto/camion/camper. Braccio snodabile e riflettore orientabile. Si collega direttamente ad una qualsiasi uscita USB.

USB book reader led lamp, indispensable for light laptop keyboard, for use in car/truck/camper. Flexible arm and adjustable reflector. Is possible to connect directly with any USB output.

Caratteristiche tecniche:

- Alimentazione: USB 5V, non necessita di batterie
- Fonte luminosa: 5 led bianchi ultra luminosi
- Grado di protezione: IP20
- Resistente agli urti: IK03
- Temperatura di funzionamento: 0 +40°C
- Colore corpo: argento

Technical features:

- Power supply: USB 5V, no need batteries
- Light source: 5 high brightness white leds
- Protection degree: IP20
- Shockproof: IK03
- Working temperature: 0 +40°C
- Colour: silver

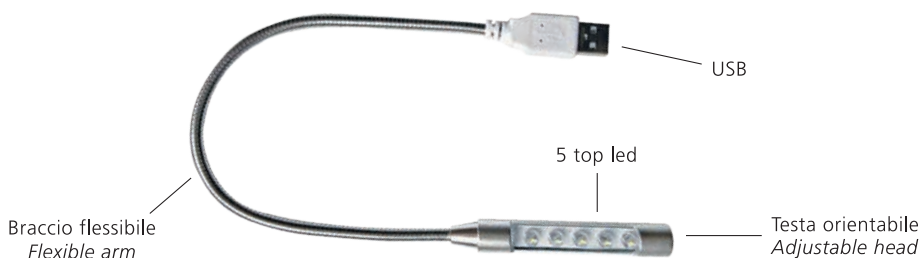

Articolo Item	Descrizione Description	Batterie Batteries	Flusso Flux	Peso Weight		€
*DU400	Leggilibro led	-	15.000 mcd	37 gr	24	3,76

*I prodotti contraddistinti da asterisco sono in confezione blisterata già pronta per gli espositori di vendita.
*Products marked by an asterisk are in a blister package ready for shop displays..



COOLSPOT

Lanternina ricaricabile con fascio di luce concentrato

6 LED bianchi ultraluminosi

Riflettore Ø 65 mm con parabola ad alta diffusione luminosa

Corpo in robusta plastica antiurto, ghiera con finitura gommata

Dimensioni compatte: 140 x 150 mm

Autonomia (a piena carica) 20 ore circa

Dotata di alimentatore 230 V~ 6V = 200 mA

☑ CE ☑ and adattatore 12 V per auto

Colore: corpo arancione, con riflettore protetto da ghiera con finitura gommata nera

Small rechargeable lantern with concentrated light beam

6 ultra-bright white LEDs

Reflector Ø 65 mm with high light diffusion parabola
Body in sturdy shockproof plastic, ring with rubber finish

Compact size: 140 x 150 mm

Autonomy (at full charge) 20 hours approx.

Fitted with driver 230 V~ 6V = 200 mA

☑ CE ☑ and 12 V car adapter

Colour: orange body, with reflector protected by ring in black rubber finish

Articolo | Item

Descrizione | Description



€

*GW.302

Lanternina ricaricabile led | Rechargeable LED lantern

6

13,55



MINILYVIALITE



Minilampada led ricaricabile a spina, con accensione automatica in mancanza di tensione alla rete.

Diventa una torcia portatile ed è molto utile durante i black-out. Reinserita nella presa di corrente si ricarica automaticamente e come "luce veglia" diffonde una tenue luce notturna.

Corpo in ABS antiurto e schermo in acrilico, isolamento in classe II.

• Funziona con batterie ricaricabili Ni-Cd 3,6V 80mAh (non sostituibili)

• LED bianco 3000°K ultraluminoso

• Autonomia circa 3 ore a batteria carica

• Interruttore: auto/spento

Plug-in rechargeable mini LED lamp, with automatic switch on if mains voltage is down.

It becomes a portable torch and is very useful during black-outs. Plugged into the socket it charges automatically and diffuses a soft light as a nightlight. Body in shockproof ABS and acrylic screen, class II insulation.

• Works with rechargeable Ni-Cd batteries 3.6V 80mAh (non replaceable)

• Ultra-bright white LED 3000°K

• Autonomy approx 3 hours at full charged

• Switch: autoloff

Articolo
Item

Dimensione (compreso spina)
Dimensions (including plug)

Alimentazione
Power supply

Grado di protezione
Protection degree

Colore
Colour



€

* 2328

90 x 60 x 75 mm

220-240 V~ 50 Hz

IP40

bianco | white

24

14,35



KRYPTON
+ 70%

EXECUTIVE

Corpo in materiale plastico antiurto, impermeabile

Interruttore a pulsante sottogomma, impermeabile

Riflettore: Ø 90 mm

Dimensioni: Ø 115 x 190 mm

Lampadina **Krypton** 4,8 V 0,75 A

4 batterie torcia R20

Colori: assortiti

Body in shockproof plastic material, waterproof

Rubber seal switch, waterproof

Reflector: Ø 90 mm

Dimensions: Ø 115 x 190 mm

Krypton 4.8 V 0,75 A Lamp

4 R20 batteries

Colours: assorted

Articolo | Item

Descrizione | Description



€

3034.D

Lanternina alogena a batteria | Battery halogen lantern

6/24

8,13



Talent

CE



Facile messa a fuoco da SPOT a FLOOD azionando la testa in su e in giù

Easy focus from SPOT TO FLOOD moving the head up and down

Torce in robusta lega di alluminio, tipo aerospaziale, antiurto, impermeabile grazie agli O-ring di tenuta. Rivestite in morbida gomma vulcanizzata per garantire un'efficace presa ed evitare il rotolamento.
Riflettore progettato al computer per ottenere la massima diffusione.
Lente infrangibile.
Lampadina al gas XENON 3100° K
Finitura di pregio anodizzata opaca.

Torches in aerospace aluminium alloy, shockproof and waterproof, thanks to special o-ring. Coated in vulcanized soft rubber to permit safe hand grip and no roll.
Special design at computer reflector for maximum light diffusion.
Unbreakable lens.
Xenon 3100°K gas lamp
Matte anodized finish.

1 elemento ministolto R03 (AAA) - incluso
Riflettore Ø 13 mm
Con cinturino anticaduta

1 R03 element (AAA) - included
Reflector Ø 13 mm
With fall arrest strap

Articolo Item	Batterie Batteries	Riflettore Reflector	Dimensioni Dimensions		€
*3322	1 x R03 (AAA)	Ø 13 mm	Ø 18 x 90 mm	12	5,02

Lampadina di ricambio | Spare bulb

Articolo Item	Tipo Type	Volt	Amp	N° lamp./blister		€
*T1	Xenon	1,2	0,3	2	12	1,11

Espositore da banco pronto per l'uso e completo di 12 torce art. 3322 | Counter display ready for use and complete with 12 torches item 3322

Articolo Item	Descrizione Description		€
EXT. 3322	Espositore 12 torce 12 torches display	1	57,80



TIGER

1 led bianco ultraluminoso
LED: 3,3 V - 1 W - 60 lm
2 elementi torcia R20 (D) - non inclusi
Interruttore sottogomma

1 ultra-bright white led
LED: 3,3 V - 1 W - 60 lm
2 R20 elements (D) - not included
Sealed rubber pushbutton

Articolo Item	Batterie Batteries	Riflettore Reflector	Dimensioni Dimensions		€
*9702	2 x R20 (D)	Ø 50 mm	Ø 50 x 260 mm	12	19,00

Alimentatori multitensione stabilizzati

Stabilised multi-voltage drivers

LYVIA



Enersafe

Costruiti nel rispetto della nuova Direttiva Europea **EuP**. L'alta efficienza energetica consente un notevole risparmio di energia

Constructed in compliance with the new **EuP** European Directive. The high energy efficiency translates into considerable energy savings

ALIMENTATORE STABILIZZATO

Tensione d'ingresso:
100-240 V~ 60/50Hz 10 W (max)
Tensione d'uscita:
3 - 4,5 - 5 - 6 - 7,5 - 9 - 12 V c.c. 7,2 VA (max)
Selettore rotativo
Indicatore luminoso di funzionamento
Protezione automatica dei sovraccarichi
Protezione contro i corto circuiti
Protezione contro il surriscaldamento
6 spinotti di collegamento

STABILISED DRIVER

Input voltage:
100-240 V~ 60/50Hz 10 W (max)
Output voltage:
3 - 4.5 - 5 - 6 - 7.5 - 9 - 12 V DC 7.2 VA (max)
Rotary selector
Light signaller indicates working
Automatic overload protection
Protection against short circuits
Protection against overheating
6 connecting jacks

Articolo Item	Dimensioni Dimensions	Corrente d'uscita Output current	Colore Colour		€
991.EUP	69x39x31mm	600 mA (max)	argento silver	50	9,33



Enersafe

ALIMENTATORE STABILIZZATO
Tensione d'ingresso:
100-240 V~ 60/50Hz 16,5 W (max)
Tensione d'uscita:
3 - 4,5 - 5 - 6 - 7,5 - 9 - 12 V c.c. 12 VA (max)
Selettore rotativo
Indicatore luminoso di funzionamento
Protezione automatica dei sovraccarichi
Protezione contro i corto circuiti
Protezione contro il surriscaldamento
6 spinotti di collegamento

STABILISED DRIVER
Input voltage:
100-240 V~ 60/50Hz 16.5 W (max)
Output voltage:
3 - 4.5 - 5 - 6 - 7.5 - 9 - 12 V DC 12 VA (max)
Rotary selector
Light signaller indicates working
Automatic overload protection
Protection against short circuits
Protection against overheating
6 connecting jacks

Articolo Item	Dimensioni Dimensions	Corrente d'uscita Output current	Colore Colour		€
997.EUP	75x43x32mm	1000 mA (max)	argento silver	20	11,25



Enersafe

ALIMENTATORE STABILIZZATO
Tensione d'ingresso:
100-240 V~ 60/50Hz 23,7 W (max)
Tensione d'uscita:
3 - 4,5 - 5 - 6 - 7,5 - 9 - 12 V c.c. 18 VA (max)
Selettore rotativo
Indicatore luminoso di funzionamento
Protezione automatica dei sovraccarichi
Protezione contro i corto circuiti
Protezione contro il surriscaldamento
6 spinotti di collegamento

STABILISED DRIVER
Input voltage:
100-240 V~ 60/50Hz 23.7 W (max)
Output voltage:
3 - 4.5 - 5 - 6 - 7.5 - 9 - 12 V DC 18 VA (max)
Rotary selector
Light signaller indicates working
Automatic overload protection
Protection against short circuits
Protection against overheating
6 connecting jacks

Articolo Item	Dimensioni Dimensions	Corrente d'uscita Output current	Colore Colour		€
992.EUP	82x52x36mm	1500 mA (max)	argento silver	20	15,80

Alimentatore non stabilizzato

Not stabilised driver

LYVIA



ALIMENTATORE NON STABILIZZATO

Entrata: 220 V~ 50 Hz
Uscita: 1,5 - 3 - 4,5 - 6 - 7,5 - 9 - 12 V c.c. 3,6 VA max
Led indicatore di funzionamento
Inversione di polarità
6 spinotti di collegamento
Con spina incorporata per innesto diretto alla presa (PLUG-IN)

NON STABILISED DRIVER

Input: 220 V~ 50 Hz
Output: 1.5 - 3 - 4.5 - 6 - 7.5 - 9 - 12 VDC 3.6 VA max
Operating indicator LED
Polarity inversion
6 connecting jacks
With built-in plug for direct PLUG-IN

Articolo Item	Corrente d'uscita Output current	Potenza Power		€
681.U	DC 300 mA	9 W	20	4,79

Provabatterie

Battery tester

CE



Tester tascabile in grado di indicare chiaramente la carica delle batterie (torcia - mezza torcia - stilo - ministilo - transistor 9V)

Pocket tester able to clearly indicate battery charge (R20 - R14 - R6 - R03 - transistor 9V)

La scala colorata indica lo stato della batteria

The colour scale indicates battery status

Articolo Item	Dimensioni Dimensions		€
* MS.228C	108 x 60 x 23 mm	10	3,93

Carica batterie per accumulatori ermetici

Battery charger for hermetic accumulators

LYVIA



Caricabatterie per Ni-Cd e Ni-MH

Caricabatterie universale Ni-Cd e Ni-MH per batterie ministilo (AAA), stilo (AA), 1/2 torcia (C), torcia (D). Ricarica contemporaneamente o singolarmente da 1 a 4 batterie ministilo, stilo, 1/2 torcia, torcia, e sino a 2 batterie 9 V (fino a 2000 mAh). LED rosso indica il processo di carica in corso. Dotato di indicatori Led dello stato di carica.

Battery charger for Ni-Cd and Ni-MH

Universal Ni-Cd and Ni-MH battery charger for batteries (AAA), (AA), (C), (D). It simultaneously or individually charges from 1 to 4 batteries, R03 (AAA), R6 (AA), R14 (C), R20 (D), and up to 2 batteries 9 V (up to 2000 mAh). Red LED indicates charging process in progress. Fitted with charge status LED indicators.

Articolo Item	Dimensioni Dimensions	Alimentazione Power supply	Corrente di carica Charging current	Colore Colour		€
3398.GS	192 x 95 x 48 mm	220 V~ 50 Hz	200 mA	argento silver	10	13,60



Caricabatterie per Ni-Cd e Ni-MH

Caricabatterie in ABS con spina incorporata. Si possono ricaricare contemporaneamente: 4 batterie stilo (AA) Ni-Cd e Ni-MH (150 mA) fino a 2300 mAh, 4 batterie ministilo (AAA) Ni-Cd e Ni-MH (70 mA) fino a 2300 mAh. Dotato di indicatori LED dello stato di carica.

Battery charger for Ni-Cd and Ni-MH

Battery charger in ABS with built-in plug. The following may be simultaneously charged: 4 R6 (AA) batteries Ni-Cd and Ni-MH (150 mA) up to 2300 mAh. 4 R03 batteries (AAA) Ni-Cd and Ni-MH (70 mA) up to 2300 mAh. Fitted with charge status LED indicators.

Articolo Item	Dimensioni Dimensions	Alimentazione Power supply	Corrente di carica Charging current	Colore Colour		€
1281.3GS	106 x 51,5 x 91 mm	230 V~ 50 Hz	150 mA	bianco white	10	5,59

SPINOTTERIA, MULTIPRESE

ACCESSORI PER TV-VIDEO E TELEFONIA

PLUGS, SOCKETS MULTISOCKETS

TV-VIDEO AND TELEPHONE ACCESSORIES



CON UN SOLO ADATTATORE.....
SI VIAGGIA IN TUTTO IL MONDO

WITH ONE SINGLE ADAPTER...
TRAVEL WORLDWIDE

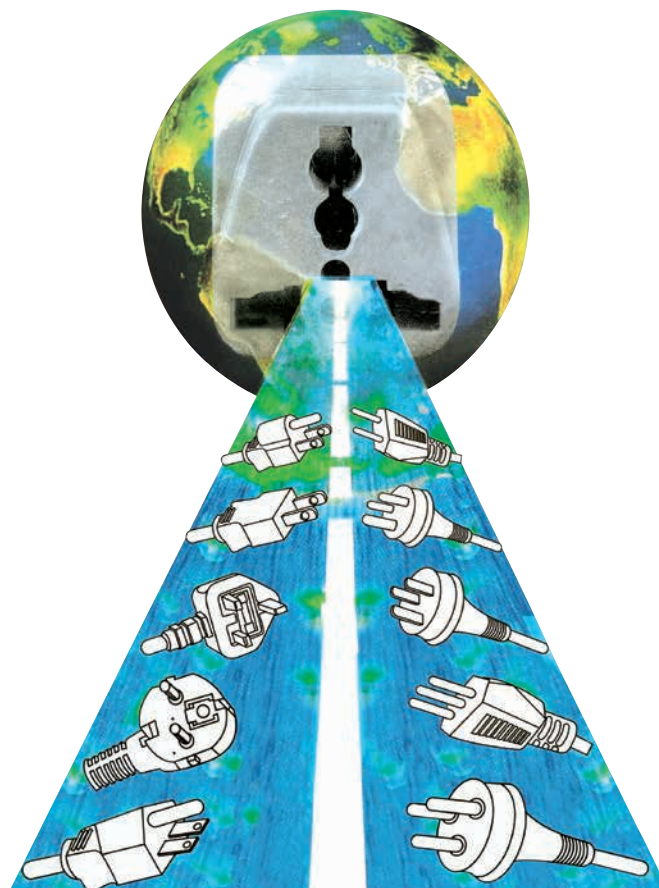

Modello brevettato | Patented model

ALL IN ONE

L'unità base è una multipresa universale con alveoli protetti sulla quale possono essere innestati i diversi tipi di spine max 16 A - 250 V

ALL IN ONE

The base unit is a universal multisocket with child protection, on which various types of plugs - max 16 A - 250 V - may be plugged in.

U.S.A.	U.S.A.	Inghilterra	England	Olanda	Holland	Italia	Italy
Taiwan	Taiwan	Hong Kong	Hong Kong	Germania	Germany	Svizzera	Switzerland
Giappone	Japan	Singapore	Singapore	Francia	France	e paesi dove	and countries
Canada	Canada	Malesia	Malaysia	Indonesia	Indonesia	si usano	where 2 round
Filippine	Philippines			Corea	Korea	2 spinotti	pins
Tailandia	Thailand					rotondi	are used
Cina	China						



Articolo | Item

Portata | Load

Colore | Colour



€

* AST.W4

16 A

bianco | white

10

13,90



Modello brevettato | *Patented model*



NANO COMPACT

UNIVERSALE

Con indicatore della tensione di rete 110 V e 220 V. Solo per apparecchi di classe II , **senza contatto di terra.**

Multipresa universale con possibilità di inserire spine italiane (senza terra centrale), svizzere, inglesi, tedesche, francesi, danesi, americane, canadesi, russe, arabe, cinesi, giapponesi e australiane.

Adatto nei paesi con prese:

125 V Taiwan, Giappone, Usa, Canada
240 V Cina, Thailandia, Filippine

Cina, Australia, Nuova Zelanda

Gran Bretagna, Hong Kong, U.A.E.,
Singapore, Malesia

U.A.E., Russia, Cina, Europa, Sud America

UNIVERSAL

With mains voltage indicator 110 V and 220 V. Only for appliances in class II , **without earth contact.**

Universal multisocket with possibility to plug in Italian (with no central earth pin), Swiss, British, German, French, Danish, American, Canadian, Russian, Arab, Chinese, Japanese and Australian plugs.

Suitable in countries with sockets:

125 V Taiwan, Japan, Usa, Canada
240 V China, Thailand, Philippines

China, Australia, New Zeland

Great Britain, Hong Kong, U.A.E.,
Singapore, Malaysia

U.A.E., Russia, China, Europe, South America

Articolo Item	Portata Load	Colore Colour		€
* WAT	10 A	nero black	10	10,95



Adatto per prese Schuko, tedesche - francobelga. Presa universale, con alveoli protetti.

Suitable for Schuko, German - French/Belgian sockets. Universal socket, with child protection.

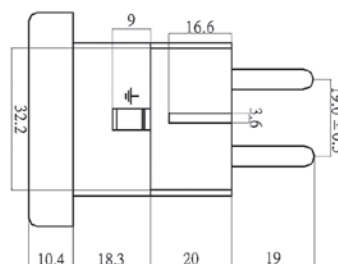
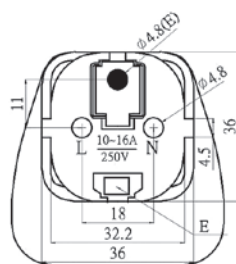

Articolo Item	Portata Load	Colore Colour		€
* WAS.9	16 A	bianco white	20	4,70

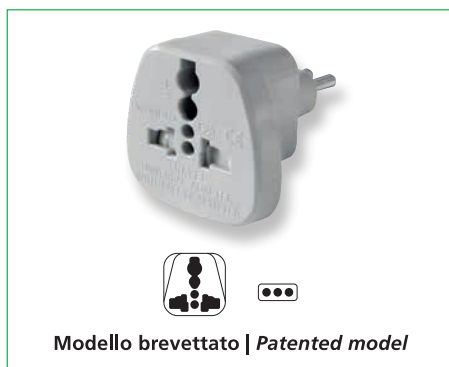

Spina italiana 10 A 2 poli + terra
Presa universale, con alveoli protetti
Adatto per le spine svizzere

*Italian plug 10 A 2 poles + earth
Universal socket with child protection
Suitable for Swiss plugs*

Articolo Item	Portata Load	Colore Colour		€
* 1660.SV	10 A	bianco ghiaccio polar white	20	6,23



Spina italiana 10 A 2 poli + terra
Presa universale, con alveoli protetti

*Italian plug 10 A 2 poles + earth
Universal socket with child protection*

Articolo Item	Portata Load	Colore Colour		€
* 1660.B	10 A	bianco ghiaccio polar white	12	3,05



Necessario per i viaggiatori che visitano Gran Bretagna, Irlanda, Gibilterra, Hong Kong, India, Cipro, Kenya, Malesia, Nigeria, Pakistan, Seychelles, Singapore.

Necessary for travellers to Great Britain, Ireland, Gibraltar, Hong Kong, India, Cyprus, Kenya, Malaysia, Nigeria, Pakistan, Seychelles, Singapore.

Con fusibile da 13 A

With 13 A fuse

Articolo Item	Portata Load	Colore Colour		€
* 1665.B	13 A	bianco ghiaccio polar white	20	4,96

Adattatori da viaggio **TOURIST**

TOURIST Travel adapters

LYVIA



Necessario per i viaggiatori che visitano Gran Bretagna, Irlanda, Gibilterra, Hong Kong, India, Cipro, Kenya, Malesia, Nigeria, Pakistan, Seychelles, Singapore.

Con fusibile da 13 A

Necessary for travellers to Great Britain, Ireland, Gibraltar, Hong Kong, India, Cyprus, Kenya, Malaysia, Nigeria, Pakistan, Seychelles, Singapore.

With 13 A fuse

Articolo Item	Portata Load	Colore Colour		€
* 1666.B	13 A	nero black	20	2,81



Necessario per i viaggiatori provenienti dalla Gran Bretagna (o aree con il sistema britannico) che visitano i paesi europei, mediterranei, scandinavi, Israele, Marocco, Russia, Tunisia, Turchia e molti paesi con il sistema europeo.

Adatto per prese italiane, svizzere (senza contatto di terra)

Necessary for travellers from Great Britain (or areas with the British system) visiting European, Mediterranean and Scandinavian countries, Israel, Morocco, Russia, Tunisia, Turkey and many countries with the European system.

Suited for Italian, Swiss sockets (without earth contact)

Articolo Item	Portata Load	Colore Colour		€
* 1670.B	10 A	nero black	20	2,69



Necessario per i viaggiatori provenienti dalla Gran Bretagna (o aree con il sistema britannico) che visitano i paesi europei, mediterranei, scandinavi, Israele, Marocco, Russia, Tunisia, Turchia e molti paesi con il sistema europeo.

Adatto per prese Schuko, tedesche - francobelga

Necessary for travellers from Great Britain (or areas with the British system) visiting European, Mediterranean and Scandinavian countries, Israel, Morocco, Russia, Tunisia, Turkey and many countries with the European system.

Suited for Schuko, German - French/Belgian sockets

Articolo Item	Portata Load	Colore Colour		€
* 1667.B	16 A	nero black	20	2,69



Fig. 1

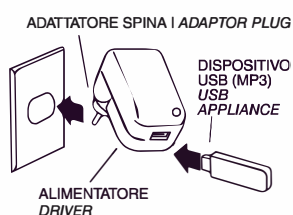
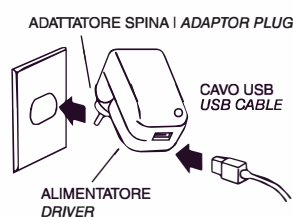

Fig. 2



Indispensabile per ricaricare la batteria via USB quando non si ha il computer a disposizione e quando si viaggia all'estero.

1 Porta USB
Indicatore luminoso di funzionamento

Questo alimentatore permette di alimentare tutti i dispositivi con connettore USB (Fig. 1) e tutti gli altri dispositivi portatili tramite il proprio cavo USB (Fig. 2).

Viene fornito con 4 spine intercambiabili per Paesi con prese:

Indispensable to recharge the battery via USB when your computer is not available and when travelling abroad.

1 USB socket
Light signaller indicates working

This driver lets you power all devices with USB connector (Fig. 1) and all other portable devices with its USB cord (Fig. 2).

It is supplied with 4 interchangeable plugs for countries with sockets:

U.S.A.	U.S.A.								
Taiwan	Taiwan	Inghilterra	England	Cina	China	Italia	Italy		
Giappone	Japan	Hong Kong	Hong Kong	Australia	Australia	Olanda	Holland		
Canada	Canada	Singapore	Singapore	Nuova Zelanda	New Zealand	Germania	Germany		
Filippine	Philippines	Malesia	Malaysia			Francia	France		
Tailandia	Thailand					Indonesia	Indonesia		
						Corea	Korea		



Articolo Item	Tensione d'ingresso Input voltage	Tensione d'uscita Output voltage	Corrente d'uscita Output current	Colore Colour		€
*900.USB	100-240 V AC~ 60/50Hz	5 V DC, 5 VA (max)	1000 mA (max)	bianco white	10/40	13,30



Spina bipolare 2P - 10A con spinotti di ottone nichelato
2 prese USB uscita 5V - 2,1A totali
Indicatore luminoso

10A - 2 pole plug with nichel-coated brass pin
2 USB outputs 5V - 2,1A total
Led indicator

Articolo Item	Tensione d'ingresso Input voltage	Tensione d'uscita Output voltage	Corrente d'uscita Output current	Colore Colour		€
*903.USB		5 V DC	2,1 A	verde green	12/48	6,74



Spina, corpo in policarbonato
spinotti in ottone nichelato annegati e protetti
fermacavo con viti
2P+T 10A 250V
costruita secondo CEI 23-5, CEI 23-16, CEI 23-50

*Plug, body in polycarbonate
embedded and protected nickel-coated brass pins
cable clamp with screws
2P+T 10A 250V
constructed according to CEI 23-5, CEI 23-16, CEI 23-50*

Articolo Item	Portata Load	Colore Colour		€
* RL.9110.B	10 A	bianco white	50/200	0,62
* RL.9110.N	10 A	nero black	50/200	0,62

Esecuzione sfusa | Bulk package

Articolo Item	Portata Load	Colore Colour		€
RLS.9110.B	10 A	bianco white	50/200	0,62
RLS.9110.N	10 A	nero black	50/200	0,62



Spina, corpo in policarbonato
spinotti in ottone nichelato annegati e protetti
fermacavo con viti
2P+T 16A 250V
costruita secondo CEI 23-5, CEI 23-16, CEI 23-50

*Plug, body in polycarbonate
embedded and protected nickel-coated brass pins
cable clamp with screws
2P+T 16A 250V
constructed according to CEI 23-5, CEI 23-16, CEI 23-50*



Articolo Item	Portata Load	Colore Colour		€
* RL.9116.B	16 A	bianco white	50/200	0,77
* RL.9116.N	16 A	nero black	50/200	0,77

Esecuzione sfusa | Bulk package

Articolo Item	Portata Load	Colore Colour		€
RLS.9116.B	16 A	bianco white	50/200	0,77
RLS.9116.N	16 A	nero black	50/200	0,77



Preso volante, corpo in policarbonato
2P+T 10A 250V con alveoli in ottone, protetti,
costruita secondo CEI 23-5, CEI 23-16, CEI 23-50

*Movable socket, body in polycarbonate
2P+T 10A 250V with child protection,
constructed according to CEI 23-5, CEI 23-16,
CEI 23-50*

Articolo Item	Portata Load	Colore Colour		€
* RL.9120.B	10 A	bianco white	50/200	0,90
* RL.9120.N	10 A	nero black	50/200	0,90

Esecuzione sfusa | Bulk package

Articolo Item	Portata Load	Colore Colour		€
RLS.9120.B	10 A	bianco white	50/200	0,90
RLS.9120.N	10 A	nero black	50/200	0,90



Preso volante, corpo in policarbonato
2P+T 10/16A 250V bipasso, alveoli in ottone, protetti
costruita secondo CEI 23-5, CEI 23-16, CEI 23-50

*Movable socket, body in polycarbonate
2P+T 10/16A 250V, with child protection
constructed according to CEI 23-5, CEI 23-16,
CEI 23-50*

Articolo Item	Portata Load	Colore Colour		€
* RL.9126.B	16 A	bianco white	50/200	0,96
* RL.9126.N	16 A	nero black	50/200	0,96

Esecuzione sfusa | Bulk package

Articolo Item	Portata Load	Colore Colour		€
RLS.9126.B	16 A	bianco white	50/200	0,96
RLS.9126.N	16 A	nero black	50/200	0,96



Spina piatta, corpo in policarbonato
spinotti in ottone nichelato annegati e protetti
fermacavo con viti
2P+T 10A 250V
costruita secondo CEI 23-5, CEI 23-16, CEI 23-50

*Flat plug, body in polycarbonate
embedded and protected nickel-coated brass pins
cable clamp with screws
2P+T 10A 250V
constructed according to CEI 23-5, CEI 23-16, CEI
23-50*

Articolo Item	Portata Load	Colore Colour		€
* RL.9112.B	10 A	bianco white	50/200	0,66
* RL.9112.N	10 A	nero black	50/200	0,66

Esecuzione sfusa | Bulk package

Articolo Item	Portata Load	Colore Colour		€
RLS.9112.B	10 A	bianco white	50/200	0,66
RLS.9112.N	10 A	nero black	50/200	0,66



Spina piatta, corpo in policarbonato
spinotti in ottone nichelato annegati e protetti
fermacavo con viti
2P+T 16A 250V
costruita secondo CEI 23-5, CEI 23-16, CEI 23-50

*Flat plug, body in polycarbonate
embedded and protected nickel-coated brass pins
cable clamp with screws
2P+T 16A 250V
constructed according to CEI 23-5, CEI 23-16, CEI
23-50*

Articolo Item	Portata Load	Colore Colour		€
* RL.9118.B	16 A	bianco white	50/200	0,78
* RL.9118.N	16 A	nero black	50/200	0,78

Esecuzione sfusa | Bulk package

Articolo Item	Portata Load	Colore Colour		€
RLS.9118.B	16 A	bianco white	50/200	0,78
RLS.9118.N	16 A	nero black	50/200	0,78



Spina reversibile, corpo in policarbonato
spinotti in ottone nichelato annegati e protetti
fermacavo con viti
2P+T 10A 250V
costruita secondo CEI 23-5, CEI 23-16, CEI 23-50

*Reversible plug, body in polycarbonate
embedded and protected nickel-coated brass pins
cable clamp with screws
2P+T 10A 250V
constructed according to CEI 23-5, CEI 23-16, CEI
23-50*

Articolo Item	Portata Load	Colore Colour		€
* RL.9113.B	10 A	bianco white	50/200	0,76
* RL.9113.N	10 A	nero black	50/200	0,76



Spina reversibile, corpo in policarbonato
spinotti in ottone nichelato annegati e protetti
fermacavo con viti
2P+T 16A 250V
costruita secondo CEI 23-5, CEI 23-16, CEI 23-50

*Reversible plug, body in polycarbonate
embedded and protected nickel-coated brass pins
cable clamp with screws
2P+T 16A 250V
constructed according to CEI 23-5, CEI 23-16, CEI
23-50*

Articolo Item	Portata Load	Colore Colour		€
* RL.9119.B	16 A	bianco white	50/200	0,86
* RL.9119.N	16 A	nero black	50/200	0,86

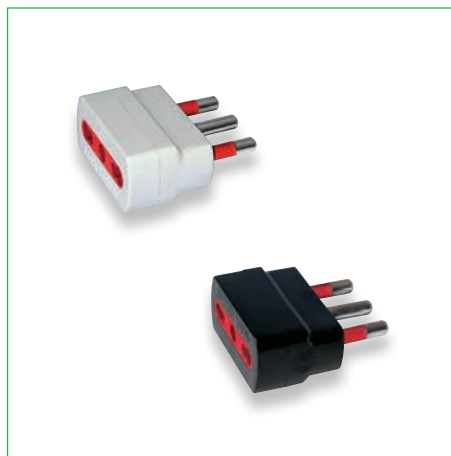

Adattatore in policarbonato
spina 2P+T 16A con spinotti in ottone nichelato
annegati e protetti
presa 2P+T 10/16A 250V bipasso con alveoli in
ottone, protetti
costruito secondo CEI 23-5, CEI 23-16, CEI 23-50

Adapter in polycarbonate
plug 2P+T 16A with embedded nickel-coated and
protected brass pins
socket 2P+T 10/16A 250V with child protection
constructed according to CEI 23-5, CEI 23-16, CEI
23-50

Articolo Item	Portata Load	Colore Colour		€
* RL.9281.B	16 A	bianco white	50/200	0,94
* RL.9281.N	16 A	nero black	50/200	0,94

Esecuzione sfusa | Bulk package

Articolo Item	Portata Load	Colore Colour		€
RLS.9281.B	16 A	bianco white	50/200	0,94
RLS.9281.N	16 A	nero black	50/200	0,94



Adattatore Schuko in policarbonato
spina Schuko 2P+T 16A
presa 2P+T 10/16A 250V bipasso con alveoli in
ottone, protetti
costruito secondo CEI 23-5, CEI 23-16, CEI 23-50

Schuko adapter in polycarbonate
Schuko plug 2P+T 16A
socket 2P+T 10/16A 250V with child protection
constructed according to CEI 23-5, CEI 23-16, CEI
23-50

Articolo Item	Portata Load	Colore Colour		€
* RL.9282.B	16 A	bianco white	50/200	1,08
* RL.9282.N	16 A	nero black	50/200	1,08

Esecuzione sfusa | Bulk package

Articolo Item	Portata Load	Colore Colour		€
RLS.9282.B	16 A	bianco white	50/200	1,08
RLS.9282.N	16 A	nero black	50/200	1,08



Adattatore triplo in policarbonato
spina 2P+T 10A con spinotti in ottone nichelato
annegati e protetti
3 prese 2P+T 10A 250V con alveoli in ottone, protetti
costruito secondo CEI 23-5, CEI 23-16, CEI 23-50

*Triple adapter in polycarbonate
plug 2P+T 10A with embedded nickel-coated and
protected brass pins
3 sockets 2P+T 10A 250V with child protection
constructed according to CEI 23-5, CEI 23-16, CEI
23-50*

Articolo Item	Portata Load	Colore Colour		€
* RL.9231.B	1500 W	bianco white	50/200	1,15
* RL.9231.N	1500 W	nero black	50/200	1,15

Esecuzione sfusa | Bulk package

Articolo Item	Portata Load	Colore Colour		€
RLS.9231.N	1500 W	nero black	50/200	1,15



Adattatore triplo in policarbonato
spina 2P+T 16A con spinotti in ottone nichelato
annegati e protetti
3 prese 2P+T 10/16A 250V bipasso con alveoli in
ottone, protetti
costruito secondo CEI 23-5, CEI 23-16, CEI 23-50

*Triple adapter in polycarbonate
plug 2P+T 16A with embedded nickel-coated and
protected brass pins
3 sockets 2P+T 10/16A 250V with child protection
constructed according to CEI 23-5, CEI 23-16, CEI
23-50*

Articolo Item	Portata Load	Colore Colour		€
* RL.9236.B	1500 W	bianco white	50/200	1,29
* RL.9236.N	1500 W	nero black	50/200	1,29

Esecuzione sfusa | Bulk package

Articolo Item	Portata Load	Colore Colour		€
RLS.9236.B	1500 W	bianco white	50/200	1,29
RLS.9236.N	1500 W	nero black	50/200	1,29



Adattatore Schuko in policarbonato
spina 2P+T 10A con spinotti in ottone nichelato
annegati e protetti
presa Schuko 2P+T 10A 250V con terra laterale e
centrale, alveoli in ottone, protetti
costruito secondo CEI 23-5, CEI 23-16, CEI 23-50

*Schuko adapter in polycarbonate
2P+T 10A plug with embedded nickel-coated and
protected brass pins
Schuko plug 2P+T 10A 250V with side and central
earth, with child protection
constructed according to CEI 23-5, CEI 23-16, CEI
23-50*

Articolo Item	Portata Load	Colore Colour		€
* RL.9287.B	10 A	bianco white	50/200	0,95
* RL.9287.N	10 A	nero black	50/200	0,95

Esecuzione sfusa | Bulk package

Articolo Item	Portata Load	Colore Colour		€
RLS.9287.B	10 A	bianco white	50/200	0,95
RLS.9287.N	10 A	nero black	50/200	0,95



Adattatore Schuko in policarbonato
spina 2P+T 16A con spinotti in ottone nichelato
annegati e protetti
presa Schuko 2P+T 16A 250V con terra laterale e
centrale, alveoli in ottone, protetti
costruito secondo CEI 23-5, CEI 23-16, CEI 23-50

*Schuko adapter in polycarbonate
plug 2P+T 16A with embedded nickel-coated and
protected brass pins
Schuko plug 2P+T 16A 250V with side and central
earth, with child protection
constructed according to CEI 23-5, CEI 23-16, CEI
23-50*

Articolo Item	Portata Load	Colore Colour		€
* RL.9288.B	16 A	bianco white	50/200	1,09
* RL.9288.N	16 A	nero black	50/200	1,09

Esecuzione sfusa | Bulk package

Articolo Item	Portata Load	Colore Colour		€
RLS.9288.B	16 A	bianco white	50/200	1,09
RLS.9288.N	16 A	nero black	50/200	1,09



Adattatore triplo in policarbonato
spina 2P+T 10A con spinotti in ottone nichelato
annegati e protetti
2 prese 2P+T 10 A +1 Schuko 10A con terra laterale
e centrale, alveoli in ottone, protetti
costruito secondo CEI 23-5, CEI 23-16, CEI 23-50.

*Triple adapter in polycarbonate
2P+T 10A plug with embedded and protected nickel-
coated brass pins
2 sockets 2P+T 10 A +1 Schuko 10A with side and
central earth, with child protection
constructed according to CEI 23-5, CEI 23-16, CEI
23-50.*

Articolo Item	Portata Load	Colore Colour		€
* RL.9239.B	1500 W	bianco white	50/200	1,40
* RL.9239.N	1500 W	nero black	50/200	1,40

Esecuzione sfusa | Bulk package

Articolo Item	Portata Load	Colore Colour		€
RLS.9239.B	1500 W	bianco white	50/200	1,40
RLS.9239.N	1500 W	nero black	50/200	1,40



Adattatore triplo in policarbonato
spina 2P+T 16A con spinotti in ottone nichelato
annegati e protetti
2 prese 2P+T 10/16A bipasso +1 Schuko 16A con
terra laterale e centrale, alveoli in ottone, protetti
costruito secondo CEI 23-5, CEI 23-16, CEI 23-50.

*Triple adapter in polycarbonate
plug 2P+T 16A with embedded and protected nickel-
coated brass pins
2 sockets 2P+T 10/16A +1 Schuko 16A with side
and central earth, with child protection
constructed according to CEI 23-5, CEI 23-16, CEI
23-50.*

Articolo Item	Portata Load	Colore Colour		€
* RL.9238.B	1500 W	bianco white	50/200	1,51
* RL.9238.N	1500 W	nero black	50/200	1,51

Esecuzione sfusa | Bulk package

Articolo Item	Portata Load	Colore Colour		€
RLS.9238.B	1500 W	bianco white	50/200	1,51
RLS.9238.N	1500 W	nero black	50/200	1,51



Adattatore quadruplo piatto in policarbonato
spina 2P+T 10A con spinotti in ottone nichelato
annegati e protetti
4 prese 2P+T 10A con alveoli in ottone, protetti
costruito secondo CEI 23-5, CEI 23-16, CEI 23-50

*Quadruple flat adapter in polycarbonate
plug 2P+T 10A with embedded and protected
nickel-coated brass pins
4 sockets 2P+T 10A with child protection
constructed according to CEI 23-5, CEI 23-16, CEI
23-50*

Articolo Item	Portata Load	Colore Colour		€
* RL.9240.N	1500 W	nero black	20/200	2,15

Esecuzione sfusa | Bulk package

Articolo Item	Portata Load	Colore Colour		€
RLS.9240.N	1500 W	nero black	20/200	2,15



Adattatore quadruplo piatto in policarbonato
spina 2P+T 16A con spinotti in ottone nichelato
annegati e protetti
4 prese 2P+T 10/16A bipasso con alveoli in ottone,
protetti
costruito secondo CEI 23-5, CEI 23-16, CEI 23-50.

*Quadruple flat adapter in polycarbonate
plug 2P+T 16A with embedded and protected
nickel-coated brass pins
4 sockets 2P+T 10/16A with child protection
constructed according to CEI 23-5, CEI 23-16, CEI
23-50.*

Articolo Item	Portata Load	Colore Colour		€
* RL.9246.B	1500 W	bianco white	20/200	2,25
* RL.9246.N	1500 W	nero black	20/200	2,25

Esecuzione sfusa | Bulk package

Articolo Item	Portata Load	Colore Colour		€
RLS.9246.B	1500 W	bianco white	20/200	2,25
RLS.9246.N	1500 W	nero black	20/200	2,25

Adattatori serie Swing

Adapters Swing series



ADATTATORE CON SPINA ROTANTE DI 90°

Consente il posizionamento anche in spazi ridotti.

Adattatore triplo in policarbonato, spina 2P+T 10A rotante di 90°, con spinotti in ottone annegati e protetti

2 prese 2P+T 10A + 1 Schuko 10A con terra laterale e centrale, con alveoli protetti

con interruttore luminoso ON/OFF

costruita secondo CEI 23-5, CEI 23-16, CEI 23-50.

ADAPTER WITH 90° ROTATING PLUG

It may be positioned even in small spaces.

Triple adapter in polycarbonate, plug 2P+T 10A rotating by 90°, with embedded and protected brass pins

2 sockets 2P+T 10A + 1 Schuko 10A with side and central earth, child protection

with ON/OFF light switch

constructed according to CEI 23-5, CEI 23-16, CEI 23-50.

Articolo Item	Portata Load	Colore Colour		€
* RL.1046.B	1500 W	bianco white	12/48	4,19



ADATTATORE CON SPINA ROTANTE DI 90°

Consente il posizionamento anche in spazi ridotti.

Adattatore triplo in policarbonato, spina 2P+T 16A rotante di 90°, con spinotti in ottone annegati e protetti

2 prese bipasso 2P+T 10/16A + 1 bipasso/Schuko 16A con terra laterale e centrale, con alveoli protetti

con interruttore luminoso ON/OFF

costruita secondo CEI 23-5, CEI 23-16, CEI 23-50.

ADAPTER WITH 90° ROTATING PLUG

It may be positioned even in small spaces.

Triple adapter in polycarbonate, plug 2P+T 16A rotating by 90°, with embedded and protected brass pins

2 sockets 2P+T 10/16A + 1 2P+T/Schuko 16A with side and central earth, child protection

with ON/OFF light switch

constructed according to CEI 23-5, CEI 23-16, CEI 23-50.

Articolo Item	Portata Load	Colore Colour		€
* RL.1044.B	1500 W	bianco white	12/48	4,29



ADATTATORE CON SPINA ROTANTE DI 90°

Adattatore triplo in policarbonato, spina 2P+T 16A rotante di 90°, con spinotti in ottone annegati e protetti

2 prese bipasso 2P+T 10/16A + 1 bipasso/Schuko 16A con terra laterale e centrale, con alveoli protetti

2 prese USB uscita 5V c.c., 500 mA

con interruttore luminoso ON/OFF

costruita secondo CEI 23-5, CEI 23-16, CEI 23-50.

ADAPTER WITH 90° ROTATING PLUG

Triple adapter in polycarbonate, plug 2P+T 16A rotating by 90°, with embedded and protected brass pins

2 sockets 2P+T 10/16A + 1 2P+T/Schuko 16A with side and central earth, child protection

2 USB ports output 5V DC, 500 mA

with ON/OFF light switch

constructed according to CEI 23-5, CEI 23-16, CEI 23-50.

Articolo Item	Portata Load	Colore Colour		€
* RL.1045.B	1500 W	bianco white	12/48	11,35

Adattatori con spina disassata

Adapters with off-centre plug



JUMBO

La forma ed il posizionamento della spina consentono di utilizzare in modo più efficace gli spazi del blocco presa.

Adattatore Jumbo quadruplo "salvaspazio" in policarbonato, con interruttore on/off e **protezione da sovraccarico** a riarmo manuale
 spina 10A con spinotti in ottone nickelato annegati e protetti
 2 prese 2P+T 10/16A bipasso
 2 prese universale bipasso/schuko

The plug shape and positioning mean the spaces of the socket block can be used more efficiently.

Quadruple adapter "space saving" in polycarbonate, with on/off switch and **overload surge protection**, manual reset.
 10A plug with embedded nickel-coated and protected brass pins
 2 socket 2P+T 10/16A
 2 sockets universal 10/16A-schuko

Articolo Item	Portata Load	Colore Colour		€
* RL.1069	1500 W	bianco white	10/50	5,80



Adattatore triplo in policarbonato, con spina disassata interruttore on/off e **protezione da sovraccarico**, a riarmo manuale
 spina 10A con spinotti in ottone nickelato annegati e protetti
 3 prese 2P+T 10/16A bipasso

Triple adapter in polycarbonate, with off-centre plug on/off switch and **overload surge protection**, manual reset
 10A plug with embedded nickel-coated and protected brass pins
 3 sockets 2P+T 10/16A

Articolo Item	Portata Load	Colore Colour		€
* RL.1073	1500 W	bianco white	10/50	4,06



Adattatore triplo in policarbonato spina 2P+T 16A con spinotti in ottone annegati e protetti
 2 prese bipasso 2P+T 10/16A + 1 Schuko 16A con terra laterale e centrale, con alveoli in ottone, protetti
 con interruttore luminoso ON/OFF
 costruito secondo CEI 23-5, CEI 23-16, CEI 23-50.

Triple adapter in polycarbonate, plug 2P+T 16A with embedded nickel-coated and protected brass pins
 2 sockets 2P+T 10/16A + 1 Schuko 16A with side and central earth, with child protection with on/off light switch
 constructed according to CEI 23-5, CEI 23-16, CEI 23-50.

Articolo Item	Portata Load	Colore Colour		€
* RL.1054.B	1500 W	bianco white	50	3,66



Adattatore triplo in policarbonato, spina 2P+T 10A con spinotti in ottone annegati e protetti
 2 prese 2P+T 10A + 1 Schuko 10A con terra laterale e centrale, con alveoli in ottone, protetti
 con interruttore luminoso ON/OFF
 costruito secondo CEI 23-5, CEI 23-16, CEI 23-50.

Triple adapter in polycarbonate, 2P+T 10A plug with embedded nickel-coated and protected brass pins
 2 plugs 2P+T 10A + 1 Schuko 10A with side and central earth, with child protection with on/off light switch
 constructed according to CEI 23-5, CEI 23-16, CEI 23-50.

Articolo Item	Portata Load	Colore Colour		€
* RL.1053.B	1500 W	bianco white	50	3,44

*I prodotti contraddistinti da asterisco sono in confezione blisterata già pronta per gli espositori di vendita.
 *Products marked by an asterisk are in a blister package ready for shop displays.

Adattatori con spina disassata

Adapters with off-centre plug



Adattatore triplo in policarbonato, spina 2P+T 16A con spinotti in ottone annegati e protetti
3 prese 2P+T 10/16A bipasso con alveoli in ottone, protetti
con interruttore luminoso ON/OFF
costruito secondo CEI 23-5, CEI 23-16, CEI 23-50.

*Triple adapter in polycarbonate, 2P+T 16A plug with embedded nickel-coated and protected brass pins
3 sockets 2P+T 10/16A with child protection with on/off light switch
constructed according to CEI 23-5, CEI 23-16, CEI 23-50.*

Articolo Item	Portata Load	Colore Colour		€
* RL.1049.B	1500 W	bianco white	50/200	3,32



Adattatore triplo in policarbonato, spina 2P+T 10A con spinotti in ottone annegati e protetti
3 prese 2P+T 10A con alveoli in ottone, protetti
con interruttore luminoso ON/OFF
costruito secondo CEI 23-5, CEI 23-16, CEI 23-50.

*Triple adapter in polycarbonate, 2P+T 10A plug with embedded nickel-coated and protected brass pins
3 sockets 2P+T 10A with child protection with on/off light switch
constructed according to CEI 23-5, CEI 23-16, CEI 23-50.*

Articolo Item	Portata Load	Colore Colour		€
* RL.1048.B	1500 W	bianco white	50/200	3,09



Adattatore in policarbonato, spina 2P+T 16A con spinotti in ottone annegati e protetti
2 prese 2P+T 10/16A bipasso con alveoli in ottone, protetti
2 prese USB uscita 5 V, 2,1 A
con interruttore luminoso ON/OFF
costruito secondo CEI 23-5, CEI 23-16, CEI 23-50.

*Adapter in polycarbonate, 2P+T 16A plug with embedded nickel-coated and protected brass pins
2 sockets 2P+T 10/16A with child protection
2 USB ports output 5 V, 2,1 A
with on/off light switch
constructed according to CEI 23-5, CEI 23-16, CEI 23-50.*

Articolo Item	Portata Load	Colore Colour		€
* RL.1058.B	1500 W	bianco white	50	9,79



Adattatore in policarbonato, spina 2P+T 10A con spinotti in ottone annegati e protetti
2 prese 2P+T 10A con alveoli in ottone, protetti
2 prese USB uscita 5 V, 2,1 A
con interruttore luminoso ON/OFF
costruito secondo CEI 23-5, CEI 23-16, CEI 23-50.

*Adapter in polycarbonate, 2P+T 10A plug with embedded nickel-coated and protected brass pins
2 sockets 2P+T 10A with child protection
2 USB port output 5 V, 2,1 A
with on/off light switch
constructed according to CEI 23-5, CEI 23-16, CEI 23-50.*

Articolo Item	Portata Load	Colore Colour		€
* RL.1057.B	1500 W	bianco white	50	9,61

CE

Adattatori salvaspazio

Space saving adapters



Adattatore triplo in policarbonato, spina 2P+T 16A con spinotti in ottone annegati e protetti
3 prese 2P+T 10/16A bipasso con alveoli in ottone, protetti
con interruttore luminoso ON/OFF
costruito secondo CEI 23-5, CEI 23-16, CEI 23-50.

Triple adapter in polycarbonate, 2P+T 16A plug with embedded nickel-coated and protected brass pins 3 sockets 2P+T 10/16A with child protection with on/off light switch constructed according to CEI 23-5, CEI 23-16, CEI 23-50.

Articolo Item	Portata Load	Colore Colour		€
* RL.1060.B	1500 W	bianco white	10/50	3,15



Adattatore triplo in policarbonato, spina 2P+T 10A con spinotti in ottone annegati e protetti
3 prese 2P+T 10A con alveoli in ottone, protetti
con interruttore luminoso ON/OFF
costruito secondo CEI 23-5, CEI 23-16, CEI 23-50.

Triple adapter in polycarbonate, 2P+T 10A plug with embedded nickel-coated and protected brass pins 3 sockets 2P+T 10A with child protection with on/off light switch constructed according to CEI 23-5, CEI 23-16, CEI 23-50.



Articolo Item	Portata Load	Colore Colour		€
* RL.1059.B	1500 W	bianco white	10/50	2,94



Adattatore triplo in policarbonato, spina 2P+T 10A con spinotti in ottone annegati e protetti
2 prese 2P+T 10/16A + 1 schuko 10/16A con terra laterale e centrale, con alveoli in ottone,
con interruttore luminoso ON/OFF e **protezione da sovraccarico**, a riarmo manuale
costruito secondo CEI 23-5, CEI 23-16, CEI 23-50.

Triple adapter in polycarbonate, 2P+T 16A plug with embedded nickel-coated and protected brass pins 2 sockets 2P+T 10/16A + 1 schuko 10/16A with side and central earth, with on/off light switch and overload surge protection, with manual reset constructed according to CEI 23-5, CEI 23-16, CEI 23-50.



Articolo Item	Portata Load	Colore Colour		€
* RL.1061.B	1500 W	bianco white	10/50	4,12

*I prodotti contraddistinti da asterisco sono in confezione blisterata già pronta per gli espositori di vendita.
*Products marked by an asterisk are in a blister package ready for shop displays.



Spina Schuko 10/16A 250V
spinotti in ottone nichelato, con terra laterale
fermacavo con viti

Schuko plug 10/16A 250V
nickel-coated brass pins, with side earth
cable clamp with screws

Articolo Item	Portata Load	Colore Colour		€
* RL.9022.B	16 A	bianco white	50/200	0,96
* RL.9022.N	16 A	nero black	50/200	0,96



Preso volante Schuko 16A 250V
con terra laterale e centrale
alveoli protetti

Movable Schuko socket 16A 250V
with side and central earth
child protection

Articolo Item	Portata Load	Colore Colour		€
* RL.9015.B	16 A	bianco white	50/200	1,49
* RL.9015.N	16 A	nero black	50/200	1,49

Esecuzione sfusa | Bulk package

Articolo Item	Portata Load	Colore Colour		€
RLS.9015.B	16 A	bianco white	50/200	1,49
RLS.9015.N	16 A	nero black	50/200	1,49



Adattatore Schuko triplo in policarbonato
spina Schuko 16A 250V con spinotti in ottone
3 prese Schuko 16A con terra laterale ed alveoli
protetti

Triple Schuko adapter in polycarbonate
Schuko plug 16A 250V with brass pins
3 sockets Schuko 16A with side earth and child
protection

Articolo Item	Portata Load	Colore Colour		€
* RL.501008B	3500 W	bianco white	20/100	3,89

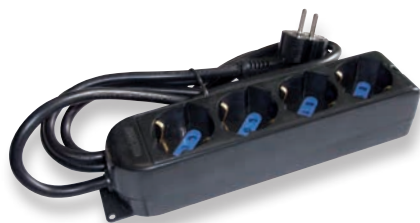

Multipresa 4
cavo H05VV-F 3x1.0mm, lung. 1.5M,
spina annegata 2P+T Schuko 16A 250V
4 prese Schuko 10/16A inclinate a 45°, con alveoli
protetti
alette per il fissaggio con tasselli e/o con fascette
costruita secondo CEI 23-57, Cei 20-20

Multisocket 4
cable H05VV-F 3x1.0mm, length 1.5M,
embedded plug 2P+T Schuko 16A 250V
4 sockets Schuko 10/16A rotated 45°, with child
protection
fins for fixing with dowels and/or straps
constructed according to CEI 23-57, Cei 20-20

Articolo Item	Portata Load	Colore Colour		€
* SL.3104.N	2500 W	nero black	40	7,40

Cavi adattatori CEE/Schuko

EEC/Schuko adapter cables



Adattatore Schuko/CEE per esterno

Spina CEE 230V 16A 2P+T
Cavo in gomma, L=30cm 3x2,5 mm²
Presa Schuko in gomma 2P+T 230V 16A, con alveoli protetti
Coperchio di protezione a chiusura stagna

Schuko/EEC outdoor adapter

EEC 230V 16A 2P+T plug
Rubber cable, L=30cm 3x2.5 mm²
Schuko rubber socket 2P+T 230V 16A, with child protection
Waterproof closing protection cover

Articolo Item	Portata Load	Colore cavo Cable colour		€
* RL.503090	16 A	nero black	10	7,00



Adattatore Schuko/CEE per esterno

Spina Schuko in gomma 2P+T 230V 16A
Cavo in gomma, L=30cm 3x2,5 mm²
Presa CEE 230V 16A 2P+T
Coperchio di protezione a chiusura stagna

Schuko/EEC outdoor adapter

Schuko rubber plug 2P+T 230V 16A
Rubber cable, L=30cm 3x2.5 mm²
EEC socket 230V 16A 2P+T
Waterproof closing protection cover

Articolo Item	Portata Load	Colore cavo Cable colour		€
* RL.503091	16 A	nero black	10	7,00

Spine inglesi

British plugs

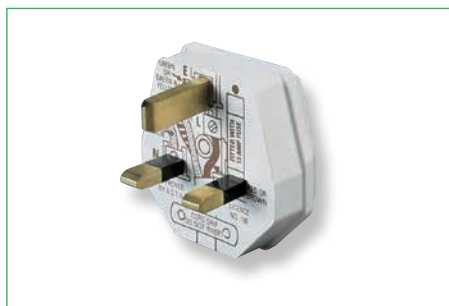

SPINA 2P+T

- standard britannica
- a norme BS 1363/A
- con fusibile 13 A incorporato

Fusibile di ricambio

- a norme BS 1362
- 13 A

PLUG 2P+T

- standard British
- compliant with BS 1363/A
- with built-in 13 A fuse

Spare fuse

- compliant with BS 1362
- 13 A

Articolo Item	Descrizione Description		€
1700	Spina 2P+T Plug 2P+T	10	2,36
SP	Fusibile di ricambio Spare fuse	10	0,51

Spine e prese in gomma Schuko

Schuko rubber plugs and sockets

LYVIA

OVE KEUR IP44



Ideali per industrie, officine, agricoltura, campeggio
temperatura di servizio -40°C +70°C

Ideal for industry, workshops, agriculture, camping
operating temperature -40°C +70°C

SPINA IN GOMMA

16 A 250 V; DIN 49441 - 2 - D - AR1, CEE 7
con frutto in robusto materiale antiurto,
con anello che rende la spina stagna IP44
per cavi fino 3 x 2,5 mm² H07RN-F
con sistema di terra franco-tedesco

RUBBER PLUG

16 A 250 V; DIN 49441 - 2 - D - AR1, EEC 7
with module in sturdy shockproof material,
with ring to make the plug waterproof IP44
for cables up to 3 x 2.5 mm² H07RN-F
with French-German earthing system

Articolo Item	Portata Load	Colore Colour		€
O.442.GT	16 A	nero black	20	5,99



OVE KEUR IP44

PRESA VOLANTE IN GOMMA

16 A 250 V; DIN 49440 - 2 - D - AR1, CEE 7
con frutto in robusto materiale antiurto,
per cavi fino 3 x 2,5 mm² H07RN-F
con coperchio di protezione a chiusura stagna

RUBBER SOCKET

16 A 250 V; DIN 49440 - 2 - D - AR1, EEC 7
with module in sturdy shockproof material,
for cables up to 3 x 2.5 mm² H07RN-F
with waterproof closing protection cover

Articolo Item	Portata Load	Colore Colour		€
452D.GT	16 A	nero black	10	10,15



OVE S IP44

PRESA TRIPLA VOLANTE IN GOMMA

16 A 250 V; DIN 49441 - 2 - AR1, CEE 7
completamente in gomma, corredata di coperchi di
protezione a chiusura stagna,
gancio per appendere

RUBBER TRIPLE SOCKET

16 A 250 V; DIN 49441 - 2 - AR1, EEC 7
completely in rubber, fitted with waterproof closing
protection covers,
hanging hook

Articolo Item	Portata Load	Colore Colour		€
454	3680 W	nero black	1/10	23,55

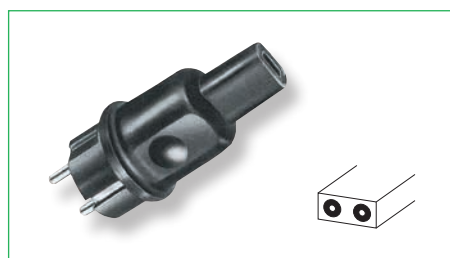

OVE KEUR IP44

SPINA IN GOMMA

adatta per il montaggio stagno del cavo piatto
5,5 x 13 mm 2 x 1,5 mm² H05RN-H2-F
10/16 A 250 V; DIN 49441 - 2 - AR1
con frutto in robusto materiale antiurto,
con anello che rende la spina stagna IP44

RUBBER PLUG

suitable for waterproof installation of flat cable
5.5 x 13 mm 2 x 1.5 mm² H05RN-H2-F 10/16 A
250 V; DIN 49441 - 2 - AR1
with module in sturdy shockproof material,
with ring to make the plug waterproof IP44

Articolo Item	Portata Load	Colore Colour		€
442.GT.F	16 A	nero black	20	7,10



SERIE NEW EASY

Nuova spina 10A
Con disgiuntore termico

Multipresa 3

Cavo H05VV-F 3x1.0 mm² lung. 1,4M
nuova spina annegata "salvaspazio" 2P+T 10A
3 uscite universali schuko + bipasso 10/16A 2P+T
inclinate di 45°, con alveoli protetti
interruttore luminoso ON/OFF, **con protezione da sovraccarico**, riarmo manuale
fori per fissaggio a parete

New 10A plug
With overload protection

Multisocket 3

cable H05VV-F 3x1.0 mm² length 1,4M
new embedded space saving plug 10A 2P+ earth
3 universal sockets Schuko 10/16A 2P+earth
rotated 45°, with child protection
ON/OFF light switch, **with overload surge protection**, manual reset
holes for wall fixing

Articolo Item	Portata Load	Colore Colour		€
* RL.3513	2500 W	bianco white	10/40	6,10



Multipresa 4

Cavo H05VV-F 3x1.0 mm² lung. 1,4M
nuova spina annegata "salvaspazio" 2P+T 10A
4 uscite universali schuko + bipasso 10/16A 2P+T
inclinate di 45°, con alveoli protetti
interruttore luminoso ON/OFF, **con protezione da sovraccarico**, riarmo manuale
fori per fissaggio a parete

Multisocket 4

cable H05VV-F 3x1.0 mm² length 1,4M
new embedded space saving plug 10A 2P+ earth
4 universal sockets Schuko 10/16A 2P+earth
rotated 45°, with child protection
ON/OFF light switch, **with overload surge protection**, manual reset
holes for wall fixing

Articolo Item	Portata Load	Colore Colour		€
* RL.3514	2500 W	bianco white	10/40	6,70



Multipresa 5

cavo H05VV-F 3x1.0 mm² lung. 1,4M
nuova spina annegata "salvaspazio" 2P+T 10A
5 uscite universali schuko + bipasso 10/16A 2P+T
inclinate di 45°, con alveoli protetti
interruttore luminoso ON/OFF, **con protezione da sovraccarico**, riarmo manuale
fori per fissaggio a parete

Multisocket 5

cable H05VV-F 3x1.0 mm² length 1,4M
new embedded space saving plug 10A 2P+ earth
5 universal sockets Schuko 10/16A 2P+earth
rotated 45°, with child protection
ON/OFF light switch, **with overload surge protection**, manual reset
holes for wall fixing

Articolo Item	Portata Load	Colore Colour		€
* RL.3515	2500 W	bianco white	10/30	7,47



Multipresa 6

cavo H05VV-F 3x1.0 mm² lung. 1,4M
nuova spina annegata "salvaspazio" 2P+T 10A
6 uscite universali schuko + bipasso 10/16A 2P+T
inclinate di 45°, con alveoli protetti
interruttore luminoso ON/OFF, **con protezione da sovraccarico**, riarmo manuale
fori per fissaggio a parete

Multisocket 6

cable H05VV-F 3x1.0 mm² length 1,4M
new embedded space saving plug 10A 2P+ earth
6 universal sockets Schuko 10/16A 2P+earth
rotated 45°, with child protection
ON/OFF light switch, **with overload surge protection**, manual reset
holes for wall fixing

Articolo Item	Portata Load	Colore Colour		€
* RL.3516	2500 W	bianco white	10/30	7,97



SERIE EASY



In tecnopolimero

Multipresa 3

cavo H05VV-F 3x1.0mm, lung. 1.4M
 spina annegata 2P+T 16A
 3 prese universali Schuko + bipasso 10/16A
 inclinate a 45°, con alveoli protetti
 interruttore luminoso ON-OFF,
 alette per il fissaggio con tasselli e/o con fascette
 costruita secondo CEI 23-57, Cei 20-20

In techno-polymer

Multisocket 3

cable H05VV-F 3x1.0mm, length 1.4M
 embedded plug P+T 16A
 3 universal sockets Schuko + 2P+T 10/16A rotated
 45°, with child protection
 ON-OFF light switch,
 fins for fixing with dowels and/or straps
 constructed according to CEI 23-57, Cei 20-20

Articolo Item	Portata Load	Colore Colour		€
* RL.3003.N	2500 W	nero black	5/40	5,83
* RL.3003	2500 W	bianco white	40	5,83

stesso modello, cavo H05VV-F 3x1,0 mm, lunghezza 3 M | same model, cable H05VV-F 3x1.0 mm, length 3 M

Articolo Item	Portata Load	Colore Colour		€
* RL.30033	2500 W	bianco white	10/30	7,37

stesso modello, con spina Schuko 16A | same model, with Schuko 16A plug

Articolo Item	Portata Load	Colore Colour		€
* RL.3003.SK	2500 W	bianco white	10/40	6,20



Multipresa 4

cavo H05VV-F 3x1.0mm, lung. 1.4M
 spina annegata 2P+T 16A
 4 prese universali Schuko + bipasso 10/16A
 inclinate a 45°, con alveoli protetti
 interruttore luminoso ON-OFF,
 alette per il fissaggio con tasselli e/o con fascette
 costruita secondo CEI 23-57, Cei 20-20

Multisocket 4

cable H05VV-F 3x1.0mm, length 1.4M
 embedded plug 2P+T 16A
 4 universal sockets Schuko + 2P+T 10/16A rotated
 45°, with child protection
 ON-OFF light switch,
 fins for fixing with dowels and/or straps
 constructed according to CEI 23-57, Cei 20-20



Articolo Item	Portata Load	Colore Colour		€
* RL.3004.N	2500 W	nero black	5/40	6,04
* RL.3004	2500 W	bianco white	40	6,04

stesso modello, cavo H05VV-F 3x1,0 mm, lunghezza 3 M | same model, cable H05VV-F 3x1.0 mm, length 3 M

Articolo Item	Portata Load	Colore Colour		€
* RL.30043	2500 W	bianco white	10/30	8,54

stesso modello, con spina Schuko 16A | same model, with Schuko 16A plug

Articolo Item	Portata Load	Colore Colour		€
* RL.3004.SK	2500 W	bianco white	10/40	6,52



SERIE EASY

Multipresa 5

cavo H05VV-F 3x1.0mm, lung. 1.4M
 spina annegata 2P+T 16A
 5 prese universali Schuko + bipasso 10/16A
 inclinate a 45°, con alveoli protetti
 interruttore luminoso ON-OFF,
 alette per il fissaggio con tasselli e/o con fascette
 costruita secondo CEI 23-57, Cei 20-20

Multisocket 5

cable H05VV-F 3x1.0mm, length 1.4M
 embedded plug 2P+T 16A
 5 universal sockets Schuko + 2P+T 10/16A rotated
 45°, with child protection
 ON-OFF light switch,
 fins for fixing with dowels and/or straps
 constructed according to CEI 23-57, Cei 20-20

Articolo Item	Portata Load	Colore Colour		€
* RL.3005.N	2500 W	nero black	5/30	6,62
* RL.3005	2500 W	bianco white	30	6,62

stesso modello, cavo H05VV-F 3x1,0 mm, lunghezza 3 M | same model, cable H05VV-F 3x1,0 mm, length 3 M

Articolo Item	Portata Load	Colore Colour		€
* RL.30053	2500 W	bianco white	10/30	9,09

stesso modello, con spina Schuko 16A | same model, with Schuko 16A plug

Articolo Item	Portata Load	Colore Colour		€
* RL.3005.SK	2500 W	bianco white	10/30	6,82



Multipresa 6

cavo H05VV-F 3x1.0mm, lung. 1.4M
 spina annegata 2P+T 16A
 6 prese universali Schuko + bipasso 10/16A
 inclinate a 45°, con alveoli protetti
 interruttore luminoso ON-OFF,
 alette per il fissaggio con tasselli e/o con fascette
 costruita secondo CEI 23-57, Cei 20-20

Multisocket 6

cable H05VV-F 3x1.0mm, length 1.4M
 embedded plug 2P+T 16A
 6 universal sockets Schuko + 2P+T 10/16A rotated
 45°, with child protection
 ON-OFF light switch,
 fins for fixing with dowels and/or straps
 constructed according to CEI 23-57, Cei 20-20

Articolo Item	Portata Load	Colore Colour		€
* RL.3006.N	2500 W	nero black	5/30	7,58
* RL.3006	2500 W	bianco white	30	7,58

stesso modello, cavo H05VV-F 3x1,0 mm, lunghezza 3 M | same model, cable H05VV-F 3x1,0 mm, length 3 M

Articolo Item	Portata Load	Colore Colour		€
* RL.30063	2500 W	bianco white	10/30	9,62

stesso modello, con spina Schuko 16A | same model, with Schuko 16A plug

Articolo Item	Portata Load	Colore Colour		€
* RL.3006.SK	2500 W	bianco white	10/30	7,81



SERIE SQUARE

CE

In tecnopolimero

Multipresa universale rettangolare
cavo H05VV-F 3x1.0mm², lung. 1,4M
spina annegata 2P+T 16A
4 prese universali Schuko + bipasso 10/16A
inclinate a 45°, con alveoli protetti
interruttore luminoso ON-OFF,
alette per il fissaggio con tasselli e/o con fascette
costruita secondo CEI 23-57, CEI 20-20

In techno-polymer

Universal rectangular multisocket
cable H05VV-F 3x1.0mm², length 1.4M
embedded plug 2P+T 16A
4 universal sockets Schuko + 2P+T 10/16A
rotated 45°, with child protection
ON-OFF light switch
fins for fixing with dowels and/or straps
constructed according to CEI 23-57, CEI 20-20

Articolo Item	Portata Load	Colore Colour		€
* RL.4004	2500 W	bianco white	30	6,26
* RL.4004.N	2500 W	nero black	30	6,26



In tecnopolimero

Multipresa universale rettangolare
cavo H05VV-F 3x1.0mm², lung. 1.4M
spina annegata 2P+T 16A
6 prese universali Schuko + bipasso 10/16A
inclinate a 45°, con alveoli protetti
interruttore luminoso ON-OFF,
alette per il fissaggio con tasselli e/o con fascette
costruita secondo CEI 23-57, CEI 20-20

In techno-polymer

Universal rectangular multisocket
cable H05VV-F 3x1.0mm², length 1.4M
embedded plug 2P+T 16A
6 universal sockets Schuko + 2P+T 10/16A
rotated 45°, with child protection
ON-OFF light switch,
fins for fixing with dowels and/or straps
constructed according to CEI 23-57, CEI 20-20

CE

Articolo Item	Portata Load	Colore Colour		€
* RL.4006	2500 W	bianco white	30	8,09
* RL.4006.N	2500 W	nero black	30	8,09

Multiprese universali senza cavo

Universal multisoquets without cable



SERIE EASY

Multipresa senza cavo d'alimentazione predisposta di morsetteria per un veloce collegamento del cavo

Multisoquet without cable fitted with terminal board for quick connection of the power supply cable



CE

Multipresa 4

4 prese universali Schuko + bipasso 10/16A inclinate a 45°, con alveoli protetti interruttore luminoso ON-OFF, alette per il fissaggio con tasselli e/o con fascette costruita secondo CEI 23-57, CEI 20-20

Multisoquet 4

4 universal sockets Schuko + 2P+T 10/16A rotated 45°, with child protection ON-OFF light switch, fins for fixing with dowels and/or straps constructed according to CEI 23-57, CEI 20-20

Articolo Item	Portata Load	Colore Colour		€
* RL.3204	2500 W	bianco white	5/40	4,48



Multipresa 6

6 prese universali Schuko + bipasso 10/16A inclinate a 45°, con alveoli protetti interruttore luminoso ON-OFF, alette per il fissaggio con tasselli e/o con fascette costruita secondo CEI 23-57, CEI 20-20

Multisoquet 6

6 universal sockets Schuko + 2P+T universal sockets 10/16A rotated 45°, with child protection ON-OFF light switch, fins for fixing with dowels and/or straps constructed according to CEI 23-57, CEI 20-20



CE

Articolo Item	Portata Load	Colore Colour		€
* RL.3206	2500 W	bianco white	5/30	5,75



SERIE PREMIUM

In tecnopolimero

Multipresa predisposta di morsetteria per un veloce collegamento del cavo di alimentazione.
4 prese 2P+T 10/16A 250V bipasso con alveoli protetti
2 prese universali Schuko + bipasso 10/16A con alveoli protetti
alette per il fissaggio con tasselli e/o con fascette costruita secondo CEI 23-57, CEI 20-20

In techno-polymer

Multisoquet fitted with terminal board for quick connection of the power supply cable.
4 sockets 2P+T 10/16A 250V with child protection
2 universal Schuko + 2P+T 10/16A sockets with child protection
fins for fixing with dowels and/or straps constructed according to CEI 23-57, CEI 20-20

CE

Articolo Item	Portata Load	Colore Colour		€
* RL.5130	2500 W	bianco white	40	4,42



SERIE FAST

In tecnopolimero

Multipresa predisposta di morsettiera per un veloce collegamento del cavo di alimentazione

Multipresa 4 senza cavo di alimentazione

4 prese 2P+T 10/16A 250V bipasso con alveoli protetti alette per il fissaggio con tasselli e/o con fascette costruita secondo CEI 23-57, CEI 20-20

In techno-polymer

Multisocket fitted with terminal board for quick connection of the power supply cable

Multisocket 4 without power supply cord

4 sockets 2P+T 10/16A 250V with child protection fins for fixing with dowels and/or straps constructed according to CEI 23-57, CEI 20-20

Articolo Item	Portata Load	Colore Colour		€
* RL.2304	2500 W	bianco white	50	2,42
* RL.2304.N	2500 W	nero black	50	2,42



Multipresa 6 senza cavo di alimentazione

6 prese 2P+T 10/16A 250V bipasso con alveoli protetti alette per il fissaggio con tasselli e/o con fascette costruita secondo CEI 23-57, CEI 20-20

Multisocket 6 without power supply cord

6 sockets 2P+T 10/16A 250V with child protection fins for fixing with dowels and/or straps constructed according to CEI 23-57, CEI 20-20

Articolo Item	Portata Load	Colore Colour		€
* RL.2306	2500 W	bianco white	40	2,86
* RL.2306.N	2500 W	nero black	40	2,86



SERIE FLAT

In tecnopolimero

Multipresa 4

cavo H05VV-F 3x1.0 mm², lung. 1.4M
spina annegata 2P+T 16A
4 prese 2P+T 10/16A 250V bipasso con alveoli protetti alette per il fissaggio con tasselli e/o con fascette costruita secondo CEI 23-57, CEI 20-20

In techno-polymer

Multisocket 4

cable H05VV-F 3x1.0 mm², length 1.4M
embedded plug 2P+T 16A
4 sockets 2P+T 10/16A 250V with child protection fins for fixing with dowels and/or straps constructed according to CEI 23-57, CEI 20-20

Articolo Item	Portata Load	Colore Colour		€
* RL.1114	2500 W	bianco white	50	4,61
* RL.1114.N	2500 W	nero black	50	4,61

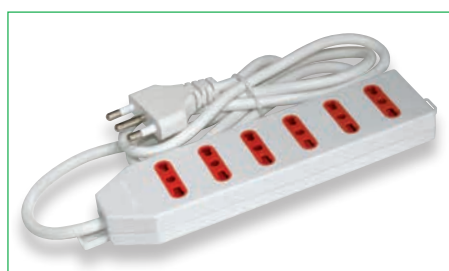

Multipresa 6

cavo H05VV-F 3x1.0 mm², lung. 1.4M
spina annegata 2P+T 16A
6 prese 2P+T 10/16A 250V bipasso con alveoli protetti alette per il fissaggio con tasselli e/o con fascette costruita secondo CEI 23-57, CEI 20-20

Multisocket 6

cable H05VV-F 3x1.0 mm², length 1.4M
embedded plug 2P+T 16A
6 sockets 2P+T 10/16A 250V with child protection fins for fixing with dowels and/or straps constructed according to CEI 23-57, CEI 20-20

Articolo Item	Portata Load	Colore Colour		€
* RL.1116	2500 W	bianco white	50	4,92



SERIE COMPACT

In tecnopolimero

Multipresa 4

cavo H05VV-F 3x1.0 mm², lung. 1.4M
 spina annegata 2P+T 16A
 4 prese 2P+T 10/16A 250V bipasso con alveoli protetti
 interruttore luminoso ON-OFF
 alette per il fissaggio con tasselli e/o con fascette
 costruita secondo CEI 23-57, CEI 20-20

In techno-polymer

Multisocket 4

cable H05VV-F 3x1.0 mm², length 1.4M
 embedded plug 2P+T 16A
 4 sockets 2P+T 10/16A 250V with child protection
 ON-OFF light switch
 fins for fixing with dowels and/or straps
 constructed according to CEI 23-57, CEI 20-20

Articolo Item	Portata Load	Colore Colour		€
* RL.3069	2500 W	bianco white	40	5,85

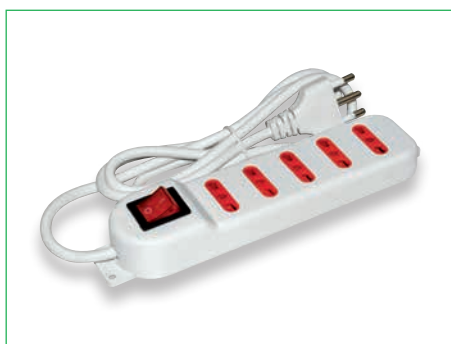

Multipresa 5

cavo H05VV-F 3x1.0 mm², lung. 1.4M
 spina annegata 2P+T 16A
 5 prese 2P+T 10/16A 250V bipasso con alveoli protetti
 interruttore luminoso ON-OFF
 alette per il fissaggio con tasselli e/o con fascette
 costruita secondo CEI 23-57, CEI 20-20

Multisocket 5

cable H05VV-F 3x1.0 mm², length 1.4M
 embedded plug 2P+T 16A
 5 sockets 2P+T 10/16A 250V with child protection
 ON-OFF light switch
 fins for fixing with dowels and/or straps
 constructed according to CEI 23-57, CEI 20-20

Articolo Item	Portata Load	Colore Colour		€
* RL.3071	2500 W	bianco white	40	5,90

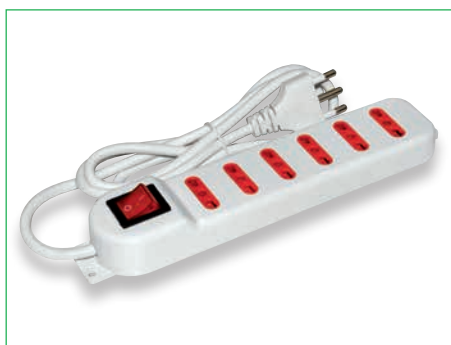

Multipresa 6

cavo H05VV-F 3x1.0 mm², lung. 1.4M
 spina annegata 2P+T 16A
 6 prese 2P+T 10/16A 250V bipasso con alveoli protetti
 interruttore luminoso ON-OFF
 alette per il fissaggio con tasselli e/o con fascette
 costruita secondo CEI 23-57, CEI 20-20

Multisocket 6

cable H05VV-F 3x1.0 mm², length 1.4M
 embedded plug 2P+T 16A
 6 sockets 2P+T 10/16A 250V with child protection
 ON-OFF light switch
 fins for fixing with dowels and/or straps
 constructed according to CEI 23-57, CEI 20-20

Articolo Item	Portata Load	Colore Colour		€
* RL.3070	2500 W	bianco white	40	6,01



SERIE NEW COMPACT

Nuova spina 10A
 Con disgiuntore termico

Multipresa 4
Cavo H05VV-F 3x1.0 mm² lung. 1,4M
nuova spina annegata "salvaspazio" 2P+T 10A
4 uscite bipasso 10/16A 2P+T con alveoli protetti
interruttore luminoso ON/OFF, **con protezione da sovraccarico**, riarmo manuale
fori per fissaggio a parete

New 10A plug
With overload protection

Multisocket 4
Cable H05VV-F 3x1.0 mm² length 1,4M
new embedded space saving plug 10A 2P+ earth
4 sockets 10/16A 2P+ earth with child protection
ON/OFF light switch, **with overload surge protection**, manual reset
holes for wall fixing

Articolo Item	Portata Load	Colore Colour		€
* RL.3814	2500 W	bianco white	10/40	6,23



Multipresa 5
Cavo H05VV-F 3x1.0 mm² lung. 1,4M
nuova spina annegata "salvaspazio" 2P+T 10A
5 uscite bipasso 10/16A 2P+T con alveoli protetti
interruttore luminoso ON/OFF, **con protezione da sovraccarico**, riarmo manuale
fori per fissaggio a parete

Multisocket 5
Cable H05VV-F 3x1.0 mm² length 1,4M
new embedded space saving plug 10A 2P+ earth
5 sockets 10/16A 2P+ earth with child protection
ON/OFF light switch,
with overload surge protection, manual reset
holes for wall fixing

Articolo Item	Portata Load	Colore Colour		€
* RL.3815	2500 W	bianco white	10/40	6,48



SERIE PREMIUM

In tecnopolimero

Multipresa 1

cavo H05VV-F 3x1.0mm², lung. 1.5M
 spina annegata 2P+T 16A
 2 prese 2P+T 10/16A 250V bipasso con alveoli protetti
 1 presa universale Schuko + bipasso 10/16A con alveoli protetti
 alette per il fissaggio con tasselli e/o con fascette
 costruita secondo CEI 23-57, CEI 20-20

In techno-polymer

Multisocket 1

cable H05VV-F 3x1.0mm², length 1.5M
 embedded plug 2P+T 16A
 2 sockets 2P+T 10/16A 250V with child protection
 1 universal Schuko + 2P+T 10/16A socket with child protection
 fins for fixing with dowels and/or straps
 constructed according to CEI 23-57, CEI 20-20

Articolo Item	Portata Load	Colore Colour		€
* RL.5123	2500 W	bianco white	50	4,51
* RL.5123.N	2500 W	nero black	50	4,51



Multipresa 2

cavo H05VV-F 3x1.0mm², lung. 1,4M
 spina annegata 2P+T 16A
 4 prese 2P+T 10/16A 250V bipasso con alveoli protetti
 2 prese universali Schuko + bipasso 10/16A con alveoli protetti
 alette per il fissaggio con tasselli e/o con fascette
 costruita secondo CEI 23-57, CEI 20-20

Multisocket 2

cable H05VV-F 3x1.0mm², length 1.4M
 embedded plug 2P+T 16A
 4 sockets 2P+T 10/16A 250V with child protection
 2 universal Schuko + 2P+T 10/16A sockets with child protection
 fins for fixing with dowels and/or straps
 constructed according to CEI 23-57, CEI 20-20

Articolo Item	Portata Load	Colore Colour		€
* RL.5126	2500 W	bianco white	40	6,57
* RL.5126.N	2500 W	nero black	40	6,57



Multipresa 2 con interruttore

cavo H05VV-F 3x1.0mm², lung. 1,4M
 spina annegata 2P+T 16A
 4 prese 2P+T 10/16A 250V bipasso con alveoli protetti
 2 prese universali Schuko + bipasso 10/16A con alveoli protetti
 interruttore luminoso ON-OFF
 alette per il fissaggio con tasselli e/o con fascette
 costruita secondo CEI 23-57, CEI 20-20

Multisocket 2 with switch

cable H05VV-F 3x1.0mm², length 1.4M
 embedded plug 2P+T 16A
 4 sockets 2P+T 10/16A 250V with child protection
 2 universal Schuko + 2P+T 10/16A sockets with child protection
 ON-OFF light switch
 fins for fixing with dowels and/or straps
 constructed according to CEI 23-57, CEI 20-20

Articolo Item	Portata Load	Colore Colour		€
* RL.5127	2500 W	bianco white	40	7,27
* RL.5127.N	2500 W	nero black	40	7,27



Multipresa 3 con interruttore

cavo H05VV-F 3x1.0mm, lung. 1,4M
 spina annegata 2P+T 16A
 6 prese 2P+T 10/16A 250V bipasso con alveoli protetti
 3 prese universali Schuko + bipasso 10/16A con alveoli protetti
 interruttore luminoso ON-OFF
 alette per il fissaggio con tasselli e/o con fascette
 costruita secondo CEI 23-57, CEI 20-20

Multisocket 3 with switch

cable H05VV-F 3x1.0mm, length 1.4M
 embedded plug 2P+T 16A
 6 sockets 2P+T 10/16A 250V with child protection
 2 universal Schuko + 2P+T 10/16A sockets with child protection
 ON-OFF light switch
 fins for fixing with dowels and/or straps
 constructed according to CEI 23-57, CEI 20-20

Articolo Item	Portata Load	Colore Colour		€
* RL.5129	2500 W	bianco white	30	8,60
* RL.5129.N	2500 W	nero black	30	8,60

* I prodotti contraddistinti da asterisco sono in confezione blisterata già pronta per gli espositori di vendita.
 *Products marked by an asterisk are in a blister package ready for shop displays.

Multiprese universali

Universal multisockets



SERIE SAFE

In tecnopolimero

Multipresa 5

5 prese universali Schuko + bipasso 10/16 A inclinate di 45°, con alveoli protetti
2 prese USB uscita 5V c.c., 500 mA
Dotata di interruttore ON/OFF a pressione posizionato su un cavo L=1m che permette l'accensione o lo spegnimento di tutte le uscite
Cavo d'alimentazione H05VV-F 3x1,0 mm², lung. 1,4 M con spina annegata 2P+T 16A

In techno-polymer

Multisocket 5

5 universal Schuko + 2P+T sockets 10/16 A rotated 45°, with child protection
2 USB sockets 5V DC, 500 mA output
ON/OFF pressure switch positioned on a cable L=1m to switch on or off all outputs
Power supply cable H05VV-F 3x1.0 mm², length 1.5 M with embedded plug 2P+T 16A

Articolo Item	Portata Load	Colore Colour		€
* RL.3605	2500 W	bianco white	6	19,70



Multipresa 4

cavo H05VV-F 3x1,0 mm², lung. 1,4 M
spina annegata 2P+T 16A
4 prese universali Schuko + bipasso 10/16 A inclinate a 45°, con alveoli protetti
Ciascuna presa è comandabile dal proprio interruttore. Dotata di interruttore di protezione dalla sovratensione e di interruttore generale, luminoso
Alette per il fissaggio con tasselli e/o con fascette

Multisocket 4

cable H05VV-F 3x1.0 mm², length 1.4 M embedded plug 2P+T 16A
4 universal Schuko + 2P+T sockets 10/16 A rotated 45°, with child protection
Each socket can be controlled by its own switch. Over-voltage protection switch and main light switch
Fins for fixing with dowels and/or with straps

Articolo Item	Portata Load	Colore Colour		€
* RL.3058	2500 W	bianco white	10	10,15

Multiprese da tavolo

Table multisockets



Corpo in policarbonato
cavo H05VV-F 3x1.0mm², lung. 2M
spina annegata 2P+T 16A
4 prese 2P+T 10/16A bipasso con alveoli protetti
1 presa Schuko 16A con terra laterale
2 prese USB uscita 5V - 1A
interruttore luminoso ON-OFF
costruita secondo CEI 23-57, CEI 20-20

Body in polycarbonate
cable H05VV-F 3x1.0mm², length 2M
embedded plug 2P+T 16A
4 sockets 2P+T 10/16A with child protection
1 Schuko 16A socket with side earth
2 USB sockets 5V, 1A output
ON-OFF light switch
constructed according to CEI 23-57, CEI 20-20



Articolo Item	Portata Load	Colore Colour		€
* RL.2604	3500 W	bianco white	6/24	16,75

Avvolgicavi

Cable reel



Avvolgicavo in ABS con **disgiuntore termico a riarmo manuale** tamburo centrale fisso, anello esterno rotante completo di cavo in PVC tipo H05VV-F 3x1.0 mm², lunghezza: **5m**
 spina annegata 2P+T 16A
 2 prese bipasso 10/16A 2P+T con alveoli protetti conforme alla norma EN 61242/A11

Cable reel in ABS with **overload surge protection with manual reset** fix central drum, rotating external ring complete with PVC cable type H05VV-F 3x1.0 mm² length: **5m**
 embedded plug 16A 2P+ earth
 2 sockets 10/16A 2P+earth with child protection compliant with standard EN 61242/A11



Articolo Item	Portata Load	Colore cavo Cable colour		€
RL.52	2200 W	nero black	10	13,35



Avvolgicavo in ABS con **disgiuntore termico a riarmo manuale** tamburo centrale fisso, anello esterno rotante completo di cavo in PVC tipo H05VV-F 3x1.5 mm², lunghezza: **10m**
 spina annegata 2P+T 16A
 4 prese universali bipasso + schuko 10/16A 2P+T con alveoli protetti conforme alla norma EN 61242/A11

Cable reel in ABS with **overload surge protection with manual reset** fix central drum, rotating external ring complete with PVC cable type H05VV-F 3x1.5 mm² length: **10m**
 with embedded plug 16A 2P+ earth
 4 sockets 10/16A + schuko 2P+earth with child protection compliant with standard EN 61242/A11



Articolo Item	Portata Load	Colore cavo Cable colour		€
RL.104	2200 W	nero black	6	28,55



Avvolgicavo a cavalletto corpo in materiale plastico supporto in tubolare metallo **disgiuntore termico a riarmo manuale** completo di cavo in PVC tipo H05VV-F 3x1.5mm², lunghezza: **15m**
 spina annegata 2P+T 16A
 4 prese universali Schuko + bipasso 10/16 A con alveoli protetti. conforme alla norma EN 61242/A11

Cable reel in plastic material metal stand **overload surge protection with manual reset** complete with PVC cable type H05VV-F 3x1.5mm² length: **15m**
 embedded plug 2P+earth 16A
 4 universal Schuko + 2P+T sockets 10/16 A with child protection. compliant with standard EN 61242/A11



Articolo Item	Portata Load	Colore cavo Cable colour		€
RL.5	2200 W	nero black	4	36,40



Avvolgicavo in ABS con **disgiuntore termico a riarmo manuale** cavo H05VV-F 3x 1.5mm lunghezza: **20m**
 spina annegata 2P+T 16A
 2 prese 2P+T 10/16A 250V bipasso
 1 presa Schuko 16 A con alveoli protetti potenza max. prelevabile: 3600W-250V conforme alla norma EN 61242/A11

Cable reel in ABS with **overload surge protection with manual reset** cable H05VV-F 3x 1.5mm length: **20m**
 embedded plug 2P+earth 16A
 2 sockets 2P+T 10/16A 250V
 1 Schuko socket 16 A with child protection max. available power: 3600W-250V compliant with standard EN 61242/A11



Articolo Item	Portata Load	Colore cavo Cable colour		€
RL.5138P	3600 W	nero black	6	39,10

Avvolgicavo ad autoavvolgimento

Self-winding cable reel



Avvolgicavo automatico ad autoavvolgimento "compatto", con dispositivo di arresto finale del cavo.

Con blocco automatico.

Corpo in materiale termoplastico resistente agli urti ed alle escursioni termiche.

Staffa di fissaggio a parete o soffitto orientabile sino a 320°.

Completo di cavo in PVC tipo H05VV-F 3x1.5mm² nero.

Spina 2P+T 16A e presa Schuko 16A 250V.

Disgiuntore termico di protezione con segnalatore e riarmo manuale.

Questo dispositivo serve a staccare automaticamente la corrente in caso di surriscaldamento del cavo sia avvolto che svolto.

Automatic "compact" cable reel, with cable end stop device.

With automatic lock.

Body in shockproof thermoplastic material and resistant to temperature changes.

Wall or ceiling fastening bracket adjustable up to 320°.

Complete with cable in PVC type H05VV-F 3x1.5mm² black.

Plug 2P+T 16A and socket Schuko 16A 250V.

Thermal protection circuit breaker with signal and manual reset.

This device is used to automatically cut off the current in the event of cable overheating, either wound or unwound.



Avvolgicavo autorientante con cavo H05VV-F 3x1.5mm²

Spina 2P+T 16A e presa Schuko 16A 250V.

Lunghezza: **11 m** (9+2)

Self-winding cable reel

with cable H05VV-F 3x1.5mm²

Plug 2P+T 16A and Socket Schuko 16A 250V.

Length: **11 m** (9+2)

Articolo Item	Portata Load	Colore cavo Cable colour		€
RL.31	3500 W	nero black	1	51,25

Prolunghe lineari

Linear extension cords



Prolunga lineare cavo H05VV-F 3x0,75mm²
spina 10A 2P+T
presa 10A con alveoli protetti
carico massimo 2000 W
conforme alle norme CEI 23-50, CEI 20-20

*Linear extension cord H05VV-F 3x0.75mm²
plug 10A 2P+T
socket 10A with child protection
maximum load 2000 W
compliant with standards CEI 23-50, CEI 20-20*

Articolo Item	Portata Load	Lunghezza Length	Colore Colour		€
* RL.1510.B	2000 W	1,5 m	bianco white	50	2,95
* RL.1510.N	2000 W	1,5 m	nero black	50	2,95
* RL.310.B	2000 W	3 m	bianco white	50	4,27
* RL.310.N	2000 W	3 m	nero black	50	4,27
* RL.510.B	2000 W	5 m	bianco white	30	6,10
* RL.510.N	2000 W	5 m	nero black	30	6,10



Prolunga lineare cavo H05VV-F 3x1,00mm²
spina 16A 2P+T
presa bipasso 10/16A con alveoli protetti
carico massimo 3500 W
conforme alle norme CEI 23-50, CEI 20-20

*Linear extension cord H05VV-F 3x1.00mm²
plug 16A 2P+T
2P+T socket 10/16A with child protection
maximum load 3500 W
compliant with standards CEI 23-50, CEI 20-20*

Articolo Item	Portata Load	Lunghezza Length	Colore Colour		€
* RL.316.B	3500 W	3 m	bianco white	50	5,37
* RL.316.N	3500 W	3 m	nero black	50	5,37
* RL.516.B	3500 W	5 m	bianco white	30	7,74
* RL.516.N	3500 W	5 m	nero black	30	7,74
* RL.816.B	3500 W	8 m	bianco white	20	10,20
* RL.816.N	3500 W	8 m	nero black	20	10,20



Prolunga antenna TV e/o apparecchi audio/video.
Cavo coassiale bianco impedenza 75Ω,
con spina e presa Ø9,5mm annegate.
Corredata di adattatore "spina- spina".
Adatta sia per segnale analogico che digitale.

*TV and audio/video extension cable.
White coaxial cable 75Ω impedance,
with Ø9,5 mm embedded plug and socket.
Provided with "socket-socket" adapter.
For analogical and digital signal.*

Articolo Item	Lunghezza Length	Colore Colour		€
* TV3002	2 m	bianco white	10	1,41
* TV3003	3 m	bianco white	10	1,64
* TV3005	5 m	bianco white	10	1,96



Prolunga antenna TV e/o apparecchi audio/video.
Cavo coassiale bianco impedenza 75Ω,
con spina diritta e presa a squadra 90°, Ø9,5mm
annegate.
Corredata di adattatore "spina-spina".
Adatta sia per segnale analogico che digitale.

*TV and audio/video extension cable.
White coaxial cable 75Ω impedance,
with Ø9,5mm embedded straight plug and 90°
angular socket.
Provided with "socket-socket" adapter.
For analogical and digital signal*

Articolo Item	Lunghezza Length	Colore Colour		€
* TV3092	2 m	bianco white	10	1,44
* TV3092B	2 m	nero black	10	1,44
* TV3093	3 m	bianco white	10	1,64



Prolunga SCART TV
Equipaggiata con 2 spine SCART 21 poli

*SCART extension cable
Equipped with 2 Scart plugs 21 pins*

Articolo Item	Lunghezza Length	Colore Colour		€
* TVSK15	1,5 m	nero black	10	1,64



Spina TV volante coassiale diritta Ø9,5 mm, per cavo coassiale con impedenza 75Ω. Adatta sia per segnale analogico che digitale.

Straight coaxial TV plug Ø9,5 mm, for 75Ω impedance coaxial cable. For analogical and digital signal.

Articolo Item	Colore Colour		€
TV1008	bianco white	20	0,20



Presa TV volante coassiale diritta Ø9,5 mm, per cavo coassiale con impedenza 75Ω. Adatta sia per segnale analogico che digitale.

Straight coaxial TV socket Ø9,5 mm, for 75Ω impedance coaxial cable. For analogical and digital signal.

Articolo Item	Colore Colour		€
TV1009	bianco white	20	0,20



Spina TV volante coassiale Ø9,5 mm a squadra 90°, per cavo coassiale con impedenza 75Ω. Adatta sia per segnale analogico che digitale.

90° angular coaxial TV plug Ø9,5 mm, for 75Ω impedance coaxial cable. For analogical and digital signal.

Articolo Item	Colore Colour		€
TV1098	bianco white	20	0,27



Presa TV volante coassiale Ø9,5 mm a squadra 90°, per cavo coassiale con impedenza 75Ω. Adatta sia per segnale analogico che digitale.

90° angular coaxial TV socket Ø9,5 mm, for 75Ω impedance coaxial cable. For analogical and digital signal.

Articolo Item	Colore Colour		€
TV1099	bianco white	20	0,27



Adattatore TV volante
1 spina e 2 prese coassiali Ø9,5 mm,
per cavo coassiale con impedenza 75Ω.
Adatta sia per segnale analogico che digitale

Coaxial TV adapter
1 plug and 2 sockets Ø9,5 mm,
for 75Ω impedance coaxial cable.
For analogical and digital signal.

Articolo Item	Colore Colour		€
TV1033	bianco white	20	0,38



Connettore TV volante coassiale a vite con spinotti
Ø9,5 mm,
per cavo coassiale con impedenza 75Ω.
Adatta per la prolunga di due cavi, sia per segnale
analogico che digitale.

Coaxial TV screw connector Ø9,5 mm,
for 75Ω impedance coaxial cable.
For analogical and digital signal extension cables.

Articolo Item	Colore Colour		€
TV1017	bianco white	20	0,28



Adattatore TV volante coassiale "presa-presa",
Ø9,5 mm,
per cavo coassiale con impedenza 75Ω.
Adatta sia per segnale analogico che digitale

Coaxial TV adapter "socket-socket" Ø9,5 mm,
for 75Ω impedance coaxial cable.
For analogical and digital signal.

Articolo Item	Colore Colour		€
TV1095	bianco white	20	0,20



Adattatore TV volante coassiale "spina-spina",
Ø9,5 mm,
per cavo coassiale con impedenza 75Ω.
Adatta sia per segnale analogico che digitale.

Coaxial TV adapter "plug-plug" Ø9,5 mm,
for 75Ω impedance coaxial cable.
For analogical and digital signal.

Articolo Item	Colore Colour		€
TV1090	bianco white	20	0,18



Cavo prolunga HDMI

- Trasmissione ad alta velocità fino a 10.2 Gbit/s
- Per una perfetta alta risoluzione Full HD, 1920x1080 pixel

HDMI extension cable

- High speed transmission of up to 10.2 Gbit/s
- For perfect high resolution full HD quality, 1920x1080 pixels

Articolo Item	Lunghezza Length	Colore Colour		€
HD101	1,5 m	nero black	10	3,27



Connettore tipo "F" in metallo per TV SAT

Metal connector type "F" for SAT TV

Articolo Item	Colore Colour		€
TVA1012	metallo metal	20	0,13



Kit adattatore satellitare
2 connettori "F" in metallo + adattatore

SAT adapter kit
2 metal connectors type "F" + adapter

Articolo Item	Colore Colour		€
TVK1012	metallo metal	10	0,49



Prolunga antenna TV SAT.
Cavo coassiale schermato impedenza 75Ω,
con connettori maschi tipo "F" annegati.

SAT TV extension cable.
shielding coaxial cable 75Ω impedance,
with 2 embedded connectors type "F".

Articolo Item	Lunghezza Length	Colore Colour		€
* TV4020	2 m	bianco white	10	1,44
* TV4030	3 m	bianco white	10	1,77



Prolunga telefonica lineare
4 conduttori con 2 plug passo 6P/4C intestati

Linear telephone cable
with 2 plug 6P/4C

Articolo Item	Lunghezza Length	Colore Colour		€
* PH9030	3 m	bianco white	10	0,61
* PH9030B	3 m	nero black	10	0,61



Prolunga telefonica estensibile
4 conduttori con 2 plug passo 4P/4C intestati

Extensible telephone cable
with 2 plug 4P/4C

Articolo Item	Lunghezza Length	Colore Colour		€
* PH9024	2,4 m	bianco white	10	0,61
* PH9024B	2,4 m	nero black	10	0,61
* PH9048	4,8 m	bianco white	10	0,89
* PH9048B	4,8 m	nero black	10	0,89



Presa telefonica tripolare da parete

3 pin telephone socket, for wall mounting

Articolo Item	Colore Colour		€
PH6080	bianco white	10	1,50



Spina telefonica tripolare
con presa plug passo 6P/4C

3 pin telephone plug,
with socket plug 6P/4C

Articolo Item	Colore Colour		€
PH6003	bianco white	10	1,35



Spina/presa telefonica passante tripolare
+ presa ADSL plug passo 6P/2C

3 pin pass-by telephone plug,
with ADSL socket plug 6P/2C

Articolo Item	Colore Colour		€
PH6020	bianco white	10	2,90



Commutatore telefonico per ADSL
1 spina plug + 2 prese plug 6P/4C.
Possibilità di usare il telefono e la linea ADSL Internet
contemporaneamente.

ADSL modem
1 plug + 2 sockets plug 6P/4C
Allows to use telephone and ADSL internet line
simultaneously

Articolo Item	Colore Colour		€
PH7022	bianco white	10	3,13



Multipresa telefonica,
cavetto con 1 spina plug passo 6P/4C + 5 prese
plug 6P/4C

5 ways telephone multisocket.
Cable with plug 6P/4C + 5 sockets 6P/4C

Articolo Item	Colore Colour		€
PH7016	bianco white	10	2,07



Preso telefonica da parete
con presa plug 6P/4C

Telephone, wall socket
with plug type 6P/4C

Articolo Item	Colore Colour		€
PH7025	bianco white	10	0,66



Accoppiatore di linea 6P/4C

6P/4C, line modular cord coupler

Articolo Item	Colore Colour		€
PH7029	bianco white	50	0,40



Accoppiatore di linea 8P/8C

8P/8C, line modular cord coupler

Articolo Item	Colore Colour		€
PH7028	bianco white	50	0,45



Adattatore da 1 spina plug 6P/4C a 2 prese plug 6P/4C

Adaptor, from 1 plug 6P/4C to 2 sockets 6P/4C

Articolo Item	Colore Colour		€
PH7012	bianco white	50	0,45



Spina RJ45 plug con contatti dorati

RJ45 plug with golden contacts

Articolo Item	N. poli-coppie Pole-couple	Colore Colour		€
PH7044	4/4	trasparente transparent	50	0,05
PH7064	6/4	trasparente transparent	50	0,05
PH7066	6/6	trasparente transparent	50	0,06
PH7088	8/8	trasparente transparent	50	0,09

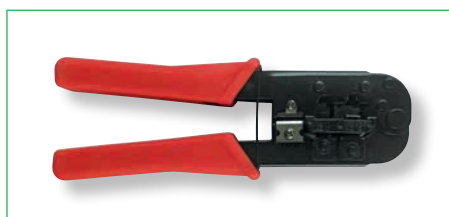

Pinza crimpatrice per connettori plug 6 e 8 poli.
Adatta per spellare cavi UTP e STP, RJ45, RJ11 e RJ12

Crimping tool for 6 and 8 C plug
Suitable for cables UTP and STP, RJ45, RJ11 and RJ12

Articolo Item	Colore Colour		€
*CRP1	nero e rosso black and red	5	11,90

Item number progressive list

Cod. Art.	€	Sconfezionabile Unpack	Q. Min	Master	Pag
AS.14	31,70	si - yes	6	24	106
AS.2309	42,75		1	6	107
AS.300	29,75	si - yes	6		109
AS.3007	43,65	si - yes	4		108
AS.309	32,70	si - yes	6		108
AS.328	18,50	si - yes	6	24	106
AS.329	24,45	si - yes	4		109
AS.335	44,65		6		107
AS.5001	43,90	si - yes	4		108
AST.W4	13,90		10		172
AW.15.12	0,38		100		22
AW.15.24	0,40		100		22
AW.16.12	0,38		100		22
AW.16.24	0,40		100		22
AW.18.12	0,38		100		22
AW.18.24	0,40		100		22
AWL31.12	4,65		10		22
AWL31.24	4,65		10		22
AWL39.12	5,53		10		22
AWL39.24	5,53		10		22
B.10.122	0,44		10		17
B.10.123	0,44		10		17
B.10.242	0,44		10		17
B.10.243	0,44		10		17
B.10.302	0,44		10		17
B.10.303	0,44		10		17
B.10.362	0,44		10		17
B.10.363	0,44		10		17
B.10.482	0,56		10		17
B.10.1102	1,20		10		17
B.10.1103	1,20		10		17
B.10.13026	1,20		10		17
B.10.2203	1,79		10		17
B.10.240	1,79		10		17
BA.9.6	0,33		100		16
BA.9.12	0,31		100		16
BA.9.12.3	0,31		100		16
BA.9.23.6	0,32		100		15
BA.9.23.12	0,35		100		15
BA.9.23.24	0,35		100		15
BA.9.23.24.3	0,35		100		15
BA.9.23.30	0,35		100		15
BA.9.23.36	0,40		100		15
BA.9.23.48	0,50		100		15
BA.9.23.60	0,55		100		15
BA.9.23.110	1,20		100		15
BA.9.23.130	1,20		100		15
BA.9.23.220	1,78		100		15
BA.9.23.240	1,80		100		15
BA.9.24.1.2	0,34		100		16
BA.9.24.2	0,34		100		16
BA.9.24.3	0,34		100		16
BA.9.30.2	0,34		100		16
BA.9.30.3	0,34		100		16

Cod. Art.	€	Sconfezionabile Unpack	Q. Min	Master	Pag
BA.9.36.2	0,39		100		16
BA.9.36.3	0,39		100		16
BA.9.48.2	0,48		100		16
BA.9.60.2	0,54		100		16
BA.9.60.3	0,54		100		16
BA.9.110.2	1,04		100		16
BA.9.110.3	1,04		100		16
BA.9.130.2	1,04		100		16
BA.9.130.2.6	1,04		100		16
BA.9.160	1,04		100		16
BA.9.220	1,48		100		16
BA.9.240	1,61		100		16
BASE.AB.35	32,20	si - yes	10		44
BASE.AL.35	33,05	si - yes	10		44
BASE.6	12,40	si - yes	30		44
BASE.21	19,65	si - yes	20		44
BASE.35	32,10	si - yes	10		44
BP.3010	2,31		25		93
BP.3011	35,95	si - yes	10		93
BP.3011.LF	57,75	si - yes	10		93
BR.CC15	1,15	si - yes	10		39
BR.CLIP	0,18	si - yes	20		39
BR05.D	13,85	si - yes	10	30	39
BR05.W	13,85	si - yes	10	30	39
BR05.WW	13,85	si - yes	10	30	39
BR08.D	17,60	si - yes	10	30	39
BR08.W	17,60	si - yes	10	30	39
BR08.WW	17,60	si - yes	10	30	39
BR13.D	20,60	si - yes	10	30	39
BR13.W	20,60	si - yes	10	30	39
BR13.WW	20,60	si - yes	10	30	39
BR19.D	25,45	si - yes	10	20	39
BR19.W	25,45	si - yes	10	20	39
BR19.WW	25,45	si - yes	10	20	39
BR21.D	30,00	si - yes	10	20	39
BR21.W	30,00	si - yes	10	20	39
BR21.WW	30,00	si - yes	10	20	39
B23.10.12	0,44		10		17
B23.10.242	0,44		10		17
B23.10.243	0,44		10		17
B23.10.362	0,44		10		17
B23.10.130	1,28		10		17
B23.10.220	2,13		10		17
CC4500	11,25		1		73
CDL.2	3,01		15		81
CDL.2.5	14,75		1		81
CG.1000	11,15		1		145
CG.2000LED	15,85		1		145
CG.3000	6,26		1		147
CG.6000	14,95		1		146
CP.63	29,30		1	6	101
CRP1	11,90	si - yes	5		212
CU.4	6,73	si - yes	12		89

Cod. Art.	€	Sconfezionabile Unpack	Q. Min	Master	Pag
DEL.41	112,95		1	4	50
DK6	1,21		10		44
DK8	1,40		10		44
DK13	2,42		10		44
DK21	3,59		10		44
DK28	4,71		10		44
DK35	6,01		10		44
DL.1077	22,85		8	16	148
DL.1090	27,40		8	16	149
DU400	3,76	si - yes	24		165
DX.400	3,21	si - yes	24		165

E.10.122	0,41		10		17
E.10.142	0,43		10		17
E.10.242	0,43		10		17
E.10.243	0,43		10		17
E.10.302	0,43		10		17
E.10.303	0,43		10		17
E.10.2203	1,74		10		17
EJB2	1,40		10		87
EJB3	2,45		5		87
EMB.7	4,20		25		29
EMC.2.7	4,20		25		28
EMC.4.7	4,20		25		28
EMC.LG.7	4,20		25		28
ESF.7	3,31		25		30
ESF.9	3,45		25		30
ESF.11	3,74		25		30
ESL.5720	5,41		10		29
ESL.5725	5,79		10		29
EXT.3322	57,80		1		167
EXT.7957	77,80		1		159
E23.10.122	0,41		10		17
E23.10.242	0,43		10		17
E23.10.243	0,43		10		17
E23.10.30	0,43		10		17
E23.10.220	2,08		10		17

F.10.6.2	0,34		100		16
F.10.12.2	0,34		100		16
F.10.14.2	0,34		100		16
F.10.23.12	0,33		100		15
F.10.23.14	0,34		100		15
F.10.23.24	0,36		100		15
F.10.23.24.3	0,36		100		15
F.10.23.30	0,36		100		15
F.10.23.36	0,39		100		15
F.10.23.60	0,52		100		15
F.10.23.110	0,93		100		15
F.10.23.220	1,69		100		15
F.10.24.2	0,36		100		16
F.10.24.3	0,36		100		16
F.10.30.2	0,37		100		16
F.10.30.3	0,37		100		16
F.10.36.3	0,39		100		16
F.10.48.3	0,46		100		16

Cod. Art.	€	Sconfezionabile Unpack	Q. Min	Master	Pag
F.10.60.3	0,52		100		16
F.10.110.2	0,94		100		16
F.10.110.3	0,94		100		16
F.10.130.2.6	1,00		100		16
F.10.220.3	1,48		100		16
F.10.240.3	1,48		100		16
FLF.6	2,61		10	100	43
FLF.6.WW	2,61		10	100	43
FLF.8	2,61		10	100	43
FLF.8.WW	2,61		10	100	43
FLF.13	3,54		10	100	43
FLF.13.WW	3,54		10	100	43
FLF.21	4,51		10	100	43
FLF.21.WW	4,51		10	100	43
FLF.28	5,48		10	100	43
FLF.28.WW	5,48		10	100	43
FLF.35	9,28		10	100	43
FLF.35.WW	9,28		10	100	43
FLF.3000.6	2,61		10	100	43
FLF.3000.21	4,51		10	100	43
FLF.3000.28	5,48		10	100	43
FLF.4100.6	2,61		10	100	43
FLF.4100.8	2,61		10	100	43
FLF.4100.13	3,54		10	100	43
FLF.4100.21	4,51		10	100	43
FLF.4100.28	5,48		10	100	43
FLF.4100.35	9,28		10	100	43
FR12.1	104,70		1		110
FT.7	9,53	si - yes	20		94
FT.7.CB	9,86	si - yes	10		94
FT.3001	20,85	si - yes	10		94
FT.8300	15,30	si - yes	10		94
FT.8300.CB	18,60	si - yes	10		94

GG.140	17,55	si - yes	6		91
GKO8.D	9,68	si - yes	10		46
GKO12.D	12,75	si - yes	10		46
GKT8.D	9,68	si - yes	10		46
GKT12.D	12,75	si - yes	10		46
GLE	9,72		1		110
GP1570	12,10		5		73
GW.302	13,55	si - yes	6		166
GW.2000	57,05	si - yes	8	16	144
GW.2003	31,50	si - yes	8	16	147
GW.6000	64,15	si - yes	6	12	146
G46100	13,25		3		72

HD101	3,27		10		209
HF.320	63,25	si - yes	6		101
HL.310	2,57		20		21
HL.312	2,46		20		21
HL006	12,80	si - yes	10		48
HL032	4,89		12		48
HL037	4,38		12		48
HL043	4,21		12		48
HR.0604	17,70		1		145

Cod. Art.	€	Sconfezionabile Unpack	Q. Min	Master	Pag
HU.10	123,40	si - yes	5		55
HU.15	146,65	si - yes	5		55
HU.20	156,00	si - yes	5		55
HU.25	174,70	si - yes	5		55
LB.924.B	3,22		10		6
LB.924.G	2,11		10		6
LB.924.R	2,18		10		6
LB.924.V	3,89		10		6
LB.924.W	3,42		10		6
LB.1024.B	3,22		10		6
LB.1024.G	2,08		10		6
LB.1024.W	3,39		10		6
LB.9130.R	2,11		10		6
LB.9130.V	3,78		10		6
LB.9130.W	3,49		10		6
LB.9240.B	3,22		10		6
LB.9240.G	2,08		10		6
LB.9240.R	2,11		10		6
LB.9240.V	3,78		10		6
LB.9240.W	3,49		10		6
LB.10130.B	3,12		10		6
LB.10130.G	1,96		10		6
LB.10130.R	1,99		10		6
LB.10130.V	3,67		10		6
LB.10130.W	3,38		10		6
LB.10240.B	3,12		10		6
LB.10240.W	3,42		10		6
LIR.34.24	0,74		50		18
LIR.34.60	0,74		50		18
LIR.34.220	1,56		50		18
LIR.34.260	1,45		50		18
LIR.35.24	0,68		50		18
LIR.35.30	0,68		50		18
LIR.35.130	1,06		50		18
LIR.35.220	1,45		50		18
LNK.AL.13.WW	21,45	si - yes	30		41
LNK.AL.21.WW	28,35	si - yes	20		41
LNK.AL.28.WW	34,35	si - yes	20		41
LNK.AL.35.WW	42,50	si - yes	10		41
LNK.CC15	1,60		10		44
LNK.CC15.PP	1,90		10		45
LNK.CC50	1,96		10		44
LNK.CC50.PP	3,45		10		45
LNK.CC100.PP	4,67		10		45
LNK.CC200	4,88		10		44
LNK.CLIP	0,44		20		45
LNK.PP	3,61	si - yes	5		45
LNK.6	13,80	si - yes	30	60	41
LNK.6.WW	13,80	si - yes	30	60	41
LNK.8	14,15	si - yes	30	60	41
LNK.8.WW	14,15	si - yes	30	60	41
LNK.13	16,50	si - yes	30	60	41
LNK.13.WW	16,50	si - yes	30	60	41
LNK.21	21,60	si - yes	20	40	41
LNK.21.WW	21,60	si - yes	20	40	41

Cod. Art.	€	Sconfezionabile Unpack	Q. Min	Master	Pag
LNK.28	24,75	si - yes	20	40	41
LNK.28.WW	24,75	si - yes	20	40	41
LNK.170	3,85		5		45
LNK.4100.6	13,80	si - yes	30	60	41
LNK.4100.8	14,15	si - yes	30	60	41
LNK.4100.13	16,50	si - yes	30	60	41
LNK.4100.21	21,60	si - yes	20	40	41
LNK.4100.28	24,75	si - yes	20	40	41
LO.1	6,16	si - yes	10		35
LYD.60	23,25	si - yes	10		104
LZ.2	2,83		12		21
LZ.3	2,83		12		21
LZ.4	2,83		12		21
LZ.13	2,83		12		21
MB.2000	6,55		1		145
MS.228C	3,93		10		169
NL.001	4,14		6		49
N400	8,60		3		73
N66100	15,70		3		72
O.442.GT	5,99		20		192
OIAA16	12,55		5		73
PH6003	1,35		10		210
PH6020	2,90		10		211
PH6080	1,50		10		210
PH7012	0,45		50		212
PH7016	2,07		10		211
PH7022	3,13		10		211
PH7025	0,66		10		211
PH7028	0,45		50		212
PH7029	0,40		50		212
PH7044	0,05		50		212
PH7064	0,05		50		212
PH7066	0,06		50		212
PH7088	0,09		50		212
PH9024	0,61		10		210
PH9024B	0,61		10		210
PH9030	0,61		10		210
PH9030B	0,61		10		210
PH9048	0,89		10		210
PH9048B	0,89		10		210
PM14	12,45		3		73
PTL.8	12,90	si - yes	30		42
PTL.13	14,80	si - yes	30		42
PTL.21	18,70	si - yes	20		42
PWR5000	26,00	si - yes	6		141
PW3079	9,17	si - yes	24		140
PW3080	10,25	si - yes	24		140
PW3081	10,60	si - yes	24		140
PW3082	15,25	si - yes	12		140
QPT	25,35		1	6	143
QP3	9,53	si - yes	6	24	142

Cod. Art.	€	Sconfezionabile Unpack	Q. Min	Master	Pag
QP4	12,40	si - yes	6	24	142
Q14	34,05	si - yes	4		138
Q26	52,40	si - yes	4		139
RF.170.I	12,80	si - yes	10		104
RH.150	24,55	si - yes	12		102
RH.500	26,00	si - yes	6		102
RL.104	28,55	si - yes	6		203
RL.1044.B	4,29		12	48	186
RL.1045.B	11,35		12	48	186
RL.1046.B	4,19		12	48	186
RL.1048.B	3,09	si - yes	50	200	188
RL.1049.B	3,32	si - yes	50	200	188
RL.1053.B	3,44	si - yes	50		187
RL.1054.B	3,66	si - yes	50		187
RL.1057.B	9,61	si - yes	50		188
RL.1058.B	9,79	si - yes	50		188
RL.1059.B	2,94		10	50	189
RL.1060.B	3,15		10	50	189
RL.1061.B	4,12		10	50	189
RL.1069	5,80		10	50	187
RL.1073	4,06		10	50	187
RL.1114	4,61	si - yes	50		198
RL.1114.N	4,61	si - yes	50		198
RL.1116	4,92	si - yes	50		198
RL.1510.B	2,95		50		205
RL.1510.N	2,95		50		205
RL.2304	2,42	si - yes	50		198
RL.2304.N	2,42	si - yes	50		198
RL.2306	2,86	si - yes	40		198
RL.2306.N	2,86	si - yes	40		198
RL.2604	16,75		6	24	202
RL.3003	5,83	si - yes	40		194
RL.3003.N	5,83		5	40	194
RL.3003.SK	6,20		10	40	194
RL.30033	7,37		10	30	194
RL.3004	6,04	si - yes	40		194
RL.3004.N	6,04		5	40	194
RL.3004.SK	6,52		10	40	194
RL.30043	8,54		10	30	194
RL.3005	6,62	si - yes	30		195
RL.3005.N	6,62		5	30	195
RL.3005.SK	6,82		10	30	195
RL.30053	9,09		10	30	195
RL.3006	7,58	si - yes	30		195
RL.3006.N	7,58		5	30	195
RL.3006.SK	7,81		10	30	195
RL.30063	9,62		10	30	195
RL.3058	10,15		10		202
RL.3069	5,85	si - yes	40		199
RL.3070	6,01	si - yes	40		199
RL.3071	5,90	si - yes	40		199
RL.31	51,25		1		204
RL.310.B	4,27		50		205
RL.310.N	4,27		50		205
RL.316.B	5,37		50		205

Cod. Art.	€	Sconfezionabile Unpack	Q. Min	Master	Pag
RL.316.N	5,37		50		205
RL.3204	4,48		5	40	197
RL.3206	5,75		5	30	197
RL.3513	6,10		10	40	193
RL.3514	6,70		10	40	193
RL.3515	7,47		10	30	193
RL.3516	7,97		10	30	193
RL.3605	19,70		6		202
RL.3814	6,23		10	40	200
RL.3815	6,48		10	40	200
RL.4004	6,26	si - yes	30		196
RL.4004.N	6,26	si - yes	30		196
RL.4006	8,09	si - yes	30		196
RL.4006.N	8,09	si - yes	30		196
RL.5	36,40		4		203
RL.501008B	3,89		20	100	190
RL.503090	7,00		10		191
RL.503091	7,00		10		191
RL.510.B	6,10		30		205
RL.510.N	6,10		30		205
RL.5123	4,51	si - yes	50		201
RL.5123.N	4,51	si - yes	50		201
RL.5126	6,57	si - yes	40		201
RL.5126.N	6,57	si - yes	40		201
RL.5127	7,27	si - yes	40		201
RL.5127.N	7,27	si - yes	40		201
RL.5129	8,60	si - yes	30		201
RL.5129.N	8,60	si - yes	30		201
RL.5130	4,42	si - yes	40		197
RL.5138P	39,10		6		203
RL.516.B	7,74		30		205
RL.516.N	7,74		30		205
RL.52	13,35	si - yes	10		203
RL.816.B	10,20		20		205
RL.816.N	10,20		20		205
RL.9015.B	1,49		50	200	190
RL.9015.N	1,49		50	200	190
RL.9022.B	0,96		50	200	190
RL.9022.N	0,96		50	200	190
RL.9110.B	0,62		50	200	177
RL.9110.N	0,62		50	200	177
RL.9112.B	0,66		50	200	179
RL.9112.N	0,66		50	200	179
RL.9113.B	0,76		50	200	180
RL.9113.N	0,76		50	200	180
RL.9116.B	0,77		50	200	177
RL.9116.N	0,77		50	200	177
RL.9118.B	0,78		50	200	179
RL.9118.N	0,78		50	200	179
RL.9119.B	0,86		50	200	180
RL.9119.N	0,86		50	200	180
RL.9120.B	0,90		50	200	178
RL.9120.N	0,90		50	200	178
RL.9126.B	0,96		50	200	178
RL.9126.N	0,96		50	200	178
RL.9231.B	1,15		50	200	182

Cod. Art.	€	Sconfezionabile Unpack	Q. Min	Master	Pag
RL.9231.N	1,15		50	200	182
RL.9236.B	1,29		50	200	182
RL.9236.N	1,29		50	200	182
RL.9238.B	1,51		50	200	184
RL.9238.N	1,51		50	200	184
RL.9239.B	1,40		50	200	184
RL.9239.N	1,40		50	200	184
RL.9240.N	2,15		20	200	185
RL.9246.B	2,25		20	200	185
RL.9246.N	2,25		20	200	185
RL.9281.B	0,94		50	200	181
RL.9281.N	0,94		50	200	181
RL.9282.B	1,08		50	200	181
RL.9282.N	1,08		50	200	181
RL.9287.B	0,95		50	200	183
RL.9287.N	0,95		50	200	183
RL.9288.B	1,09		50	200	183
RL.9288.N	1,09		50	200	183
RLS.9015.B	1,49		50	200	190
RLS.9015.N	1,49		50	200	190
RLS.9110.B	0,62		50	200	177
RLS.9110.N	0,62		50	200	177
RLS.9112.B	0,66		50	200	179
RLS.9112.N	0,66		50	200	179
RLS.9116.B	0,77		50	200	177
RLS.9116.N	0,77		50	200	177
RLS.9118.B	0,78		50	200	179
RLS.9118.N	0,78		50	200	179
RLS.9120.B	0,90		50	200	178
RLS.9120.N	0,90		50	200	178
RLS.9126.B	0,96		50	200	178
RLS.9126.N	0,96		50	200	178
RLS.9231.N	1,15		50	200	182
RLS.9236.B	1,29		50	200	182
RLS.9236.N	1,29		50	200	182
RLS.9238.B	1,51		50	200	184
RLS.9238.N	1,51		50	200	184
RLS.9239.B	1,40		50	200	184
RLS.9239.N	1,40		50	200	184
RLS.9240.N	2,15		20	200	185
RLS.9246.B	2,25		20	200	185
RLS.9246.N	2,25		20	200	185
RLS.9281.B	0,94		50	200	181
RLS.9281.N	0,94		50	200	181
RLS.9282.B	1,08		50	200	181
RLS.9282.N	1,08		50	200	181
RLS.9287.B	0,95		50	200	183
RLS.9287.N	0,95		50	200	183
RLS.9288.B	1,09		50	200	183
RLS.9288.N	1,09		50	200	183
RS6100	14,25		3		72
S.102.220	0,93		50		26
S.104.R.110.380	1,00		100		22
S.104.110	1,00		100		22
S.104.220	0,43		100		22

Cod. Art.	€	Sconfezionabile Unpack	Q. Min	Master	Pag
S.111.220	0,57		100		23
S.112.110	0,79		100		23
S.112.220	0,57		100		23
S.112.250.V	0,57		100		23
S.116.110	1,01		50		23
S.116.220	1,01		50		23
S.121.220	1,93		100		23
S.122.220	2,04		100		23
S.163.220	1,70		50		27
S.164.220	1,70		50		27
S.171.12	3,30		50		27
S.171.24	3,30		50		27
S.171.220	2,38		50		27
S.211.0.110.220.380	1,18		50		24
S.211.0.6.12.24	1,18		50		24
S.211.0.VF	1,72		50		24
S.211.110.220.380	1,18		50		24
S.211.6.12.24	1,18		50		24
S.211.VF	1,72		50		24
S.212.0.110.220.380	1,18		50		24
S.212.0.6.12.24	1,18		50		24
S.212.0.VF	1,72		50		24
S.212.110.220.380	1,18		50		24
S.212.6.12.24	1,18		50		24
S.212.VF	1,72		50		24
S.2211.0.110.220.380	1,25		50		24
S.2211.0.6.12.24	1,25		50		24
S.2211.0.VF	1,82		50		24
S.2211.110.220.380	1,25		50		24
S.2211.6.12.24	1,25		50		24
S.2211.VF	1,82		50		24
S.2212.0.110.220.380	1,25		50		24
S.2212.0.6.12.24	1,25		50		24
S.2212.0.VF	1,82		50		24
S.2212.110.220.380	1,25		50		24
S.2212.6.12.24	1,25		50		24
S.2212.VF	1,82		50		24
S.2233.0.110.220.380	1,69		50		25
S.2233.0.6.12.24	1,69		50		25
S.2233.0.VF	2,29		50		25
S.2233.110.220.380	1,69		50		25
S.2233.6.12.24	1,69		50		25
S.2233.VF	2,29		50		25
S.2243.0.110.220.380	1,69		50		25
S.2243.0.6.12.24	1,69		50		25
S.2243.0.VF	2,29		50		25
S.2243.110.220.380	1,69		50		25
S.2243.6.12.24	1,69		50		25
S.2243.VF	2,29		50		25
S.600	0,23		25		21
S.601	0,23		25		21
S.602	0,23		25		21
S.603	0,20		25		21
S.605	0,20		25		21
S.606	0,23		25		21
S.607	0,21		25		21

Cod. Art.	€	Sconfezionabile Unpack	Q. Min	Master	Pag
S.609	0,21		25		21
S.614	0,25		25		21
S.615	0,25		25		21
S.616	0,25		25		21
S.617	0,25		25		21
SAS.5	108,00		1		72
SC.2103	10,70		1	10	109
SC.3106	11,90		1	10	109
SC.313	9,92		1	10	109
SF.9.12	0,24		100		18
SF.9.24	0,31		25		18
SF.10.6	0,24		25		18
SF.10.12	0,27		25		18
SF.10.24	0,31		25		18
SF.10.30	0,31		25		18
SL.300	32,35	si - yes	6	48	98
SL.3104.N	7,40	si - yes	40		190
SM.77	118,45		1	4	103
SP	0,51		10		191
ST.8300	1,40		1		94
SW2	12,05		10		136

TB.010.12	0,97		100		26
TB.010.24	0,97		100		26
TB.010.220	0,87		100		26
TBL.010.220.A	1,59		50		26
TBL.010.220.B	1,71		50		26
TBL.010.220.R	1,47		50		26
TBL.010.220.V	1,71		50		26
TBL.010.220.W	1,84		50		26
TF.6	1,60		10		22
TF.8	1,76		10		22
TF.65	9,26		10		104
TL.3001	6,47	si - yes	12		49
TLRX.150	65,00		1		102
TLRX.500	73,00		1		102
TM1	42,60	si - yes	4		134
TM2	37,90	si - yes	4		135
TTL.CLIP	0,89		20		45
TT823	3,46		5		73
TVA1012	0,13		20		209
TVK1012	0,49		10		209
TVSK15	1,64		10		206
TV1008	0,20		20		207
TV1009	0,20		20		207
TV1017	0,28		20		208
TV1033	0,38		20		208
TV1090	0,18		20		208
TV1095	0,20		20		208
TV1098	0,27		20		207
TV1099	0,27		20		207
TV3002	1,41		10		206
TV3003	1,64		10		206
TV3005	1,96		10		206
TV3092	1,44		10		206
TV3092B	1,44		10		206

Cod. Art.	€	Sconfezionabile Unpack	Q. Min	Master	Pag
TV3093	1,64		10		206
TV4020	1,44		10		209
TV4030	1,77		10		209
T1	1,11		12		167

V30100	11,50		3		72
--------	-------	--	---	--	----

WAS.9	4,70	si - yes	20		173
WAT	10,95		10		173

ZO6	8,00		10		35
-----	------	--	----	--	----

017084	2,72		1		92
0178015	1,68		1		92
037900	2,12		10		57
037950	4,10		10		57
060290	0,84		10		57
060291	9,67		3		62
060292	0,87		10		59
060293	22,65		3		64
060295	21,10		5		62
060297	8,83		3		63
08429606	5,59		10		131

100490	5,35		1		63
100491	7,52		1		63
101023	2,21		2		61
101024	2,26		5		59
101025	2,16		2		61
101027	7,07		1		61
101028	38,65		1		67
101050	6,30		3		59
101053	6,83		5		61
101054	6,83		3		61
101055	6,83		3		61
101320	37,05		1		60
101330	49,10		1		60
101370	5,31		1		55
101800	73,70		1		60
101820	117,30		1		60
101830	136,10		1		60
102009	14,15		2		67
102010	7,25		3		66
102011	5,02		2		67
102012	9,08		3		68
102022	245,75		1		66
102023	271,40		1		66
102024	297,05		1		66
102025	356,55		1		66
102028	448,30		1		66
102032	92,40		1		66
102033	119,40		1		66
102034	146,35		1		66
102035	176,75		1		66
102038	271,50		1		66
102055	24,25		1		67

Cod. Art.	€	Sconfezionabile Unpack	Q. Min	Master	Pag
102056	26,50		1		69
102057	32,70		1		71
10219.40	267,65		1		64
10219.50	332,75		1		64
10219.60	385,80		1		64
103010	1101,55		1		70
103015	1266,80		1		70
103020	1636,15		1		70
103025	1934,20		1		70
103042	708,05		1		70
103048	1045,35		1		70
103072	369,45		1		70
103078	704,20		1		70
103080	773,75		1		70
103081	959,30		1		70
103086	1268,45		1		70
103091	1577,70		1		70
103142	353,45		1		65
103148	433,65		1		65
103200	10,10		1		71
103202	10,10		1		71
103203	10,10		1		71
103205	10,10		1		71
103207	24,20		1		71
103208	28,25		1		71
103209	9,98		1		69
103300	18,15		1		69
103301	30,30		1		69
103303	36,35		1		71
103304	26,65		1		65
103318	268,00		1		76
103319	279,30		1		76
103320	290,60		1		76
103487	9,08		1		69
103502	332,65		1		68
103504	389,75		1		68
103508	600,05		1		68
103552	225,95		1		68
103554	314,65		1		68
103558	451,55		1		68
1038.S	4,02		10		112
1040	0,95		50		36
105003	637,70		1		75
105006	679,35		1		75
105060	58,55		1		76
105070	175,65		1		76
1070	1,10		25		36
107010	867,40		1		75
107015	353,00	si - yes	2		74
107016	524,45	si - yes	2		74
107020	334,80		1		75
107025	709,10		1		74
107026	108,20		1		74
107027	198,30		1		74
108000	58,50		1		78
108001	66,05		1		78

Cod. Art.	€	Sconfezionabile Unpack	Q. Min	Master	Pag
108002	81,15		1		78
108003	94,35		1		78
108040	84,90		1		78
108041	88,65		1		78
108042	81,15		1		78
108045	118,90		1		78
108060	18,15		1		77
108061	22,65		1		77
108062	26,40		1		77
108063	43,40		1		77
108064	47,20		1		77
108065	54,75		1		77
108066	17,00		1		77
1148.S	4,15		10		113
1151.25.05	7,64		10		130
1151.25.07	7,64		10		130
1151.25.09	7,64		10		130
1152.25.55	4,42		10		130
1152.25.59	4,42		10		130
1248.S	4,15		10		112
1281.3GS	5,59		10		170
141946.B	1,61		50		37
141946.G	1,61		50		37
141946.R	1,61		50		37
141946.V	1,61		50		37
141946.W	1,61		50		37
141946.WW	1,61		100		37
142352.B	1,46		20		37
1546	1,82		50		36
1660.B	3,05		12		174
1660.SV	6,23		20		174
1665.B	4,96		20		174
1666.B	2,81		20		175
1667.B	2,69		20		175
1670.B	2,69		20		175
1700	2,36		10		191
170852	13,30		1		91
1754.110	0,80		50		19
1754.12	0,59		50		19
1754.130	0,80		50		19
1754.160	0,80		50		19
1754.220	0,97		50		19
1754.24	0,59		50		19
1754.240	0,97		50		19
1754.260	0,97		50		19
1754.30	0,59		50		19
1754.380	1,37		50		19
1754.48	0,69		50		19
1754.60	0,69		50		19
1755.160	0,86		50		19
1755.220	1,08		50		19
1755.24	0,72		50		19
1755.240	1,08		50		19
1755.380	1,44		50		19
1820	1,57		10		129
1820.01	1,52		10		129

Cod. Art.	€	Sconfezionabile Unpack	Q. Min	Master	Pag
1820.02	1,19		10		129
1825.25.06	1,39		10		121
1825.25.12	1,39		10		121
1825.25.15	1,39		10		121
1825.25.24	4,21		10		121
1826.25.07	1,68		2		126
1826.25.10	1,78		2		126
1826.25.15	1,68		2		126
1826.25.19	1,68		2		126
1826.25.24	5,54		2		126
1827.25.05	0,59		10		126
1827.25.07	0,59		10		126
1827.25.09	0,59		10		126
1827.25.10	0,69		10		126
1827.25.24	3,62		10		126
1827.25.68	4,40		10		127
1827.25.95	1,00		10		127
1827.25.97	1,00		10		127
1827.25.99	1,00		10		127
1828.25.05	3,14		10		126
1828.25.07	3,14		10		126
1828.25.09	3,14		10		126
1828.25.10	3,52		10		126
1828.25.24	8,03		10		126
1828.25.68	8,27		10		127
1828.25.95	3,83		10		127
1828.25.97	3,83		10		127
1828.25.99	3,83		10		127
1853	1,63		10		127
1883	1,92		10		129
1887	2,24		10		129
1911.01	6,02		10		130
1912.01	6,02		10		130
1975.25.09	1,45		10		128
1975.25.24	6,35		10		128
1975.25.45	2,11		10		128
1976.25.09	3,26		2		128
1976.25.24	6,47		2		128
1976.25.45	4,18		2		128
2028	10,60	si - yes	6		137
2075	13,40	si - yes	6		137
22.46.528	0,52		100		20
2219.10	3,84		20		57
2219.15	4,96		20		57
2219.20	6,37		10		57
2328	14,35	si - yes	24		166
2352.A	2,25		50		37
2352.G	2,25		50		37
2352.W	3,13		50		37
25166.GD	5,79		20		21
257	16,25		12		89
259	9,54		12		88
2601.25.05	63,05		1		125
2601.25.09	63,05		1		125
2610.25.05	72,50		1		125

Cod. Art.	€	Sconfezionabile Unpack	Q. Min	Master	Pag
2610.25.09	72,50		1		125
300	93,30		1		67
3005.A	12,45	si - yes	8		99
3005.N	12,45	si - yes	8		99
3005.V	12,45	si - yes	8		99
3034.D	8,13		6	24	166
3039.10	27,70	si - yes	20		59
3039.15	33,00	si - yes	10		59
3039.20	38,15	si - yes	10		59
3039.25	44,30	si - yes	5		59
3073	5,27	si - yes	25	100	161
3281	7,71	si - yes	12	96	157
3282	6,48	si - yes	10	40	156
3322	5,02	si - yes	12		167
3398.GS	13,60	si - yes	10		170
3650	1,52		20		33
3651	1,33		20		33
3651.25.05	5,41		10		120
3651.25.07	5,41		10		120
3651.25.09	5,41		10		120
3651.25.10	9,68		10		120
3651.25.24	6,49		10		120
3651.25.45	6,17		10		120
3653.25.05	15,60		10		121
3653.25.07	15,60		10		121
3653.25.09	15,60		10		121
3653.25.24	24,90		10		121
3656	1,52		20		33
3656.25.05	7,82		10		120
3656.25.07	7,82		10		120
3656.25.09	7,82		10		120
3656.25.24	9,38		10		120
3656.25.45	8,91		10		120
3659	1,69		20		33
3671.25.05	8,87		10		120
3671.25.09	8,87		10		120
3671.25.24	12,40		10		120
3675.25.05	15,35		10		120
3675.25.09	15,35		10		120
391	3,42		12	144	154
392	5,22	si - yes	12	96	154
393	11,55	si - yes	6	24	155
3938	2,88	si - yes	24	144	162
4185.25.02	3,06		10		122
4185.25.05	3,06		10		122
4185.25.06	3,06		10		122
4185.25.22	3,06		10		122
4185.25.25	3,06		10		122
4185.25.26	3,06		10		122
4189.02	3,85		10		131
4189.05	3,85		10		131
4195.25.02	4,34		10		122
4195.25.05	4,34		10		122
4195.25.06	4,34		10		122

Cod. Art.	€	Sconfezionabile Unpack	Q. Min	Master	Pag
4219.05	4,15		20		57
4219.10	5,91		20		57
4219.15	8,10		20		57
4219.20	10,50		10		57
4219.25	12,65		10		57
4219.30	15,10		10		57
4319.10	60,35		5		52
4319.15	78,30		5		52
442.GT.F	7,10		20		192
450015	4,28		5		53
450020	6,95		10		53
45018	1,19		25		34
45028	1,19		25		34
45118	1,19		25		34
4516.25.05	2,26		10		121
4516.25.07	2,26		10		121
4516.25.09	2,26		10		121
4516.25.24	3,34		10		121
4516.25.45	3,17		10		121
4517.25.05	15,40		10		124
4517.25.09	15,40		10		124
4519.10	47,15		5		53
4519.15	64,85		5		53
4519.20	83,65		5		53
4519.25	121,15		5		56
4519.25Y	105,10		5		53
4519.30	142,00		3		56
4519.40	183,50		3		56
4519.50	225,05		3		56
4519.60	266,60		3		56
452D.GT	10,15		10		192
45200.GS	1,10		12		90
454	23,55		1	10	192
45400	1,73		12		90
45700.GS	1,64		12		90
4580.25.05	14,45		1		125
4580.25.09	14,45		1		125
45900	2,21		12		90
46.06.020	0,71		50		20
4819.10	43,50		5		54
4819.15	59,80		5		54
4819.20	77,10		5		54
4819.25	91,20		5		54
4919.05	6,71		20		58
4919.10	8,39		20		58
4919.15	10,50		20		58
4919.20	13,10		10		58
4919.25	14,95		10		58
4919.30	16,75		10		58
50061211	3,01		10		9
50061212	3,40		10		9
50061213	3,01		10		9
50061214	3,40		10		9
50061215	3,40		10		9
50061311	3,01		10		9
50061312	3,40		10		9

Cod. Art.	€	Sconfezionabile Unpack	Q. Min	Master	Pag
50061313	3,01		10		9
50061314	3,40		10		9
50061315	3,40		10		9
50062311	3,01		10		9
50062312	3,40		10		9
50062313	3,01		10		9
50062314	3,40		10		9
50062315	3,40		10		9
50062411	3,01		10		9
50062412	3,40		10		9
50062413	3,01		10		9
50062414	3,40		10		9
50062415	3,40		10		9
50064811	3,01		10		9
50064812	3,40		10		9
50064813	3,01		10		9
50064814	3,40		10		9
50064815	3,40		10		9
50081211	3,10		10		10
50081212	3,51		10		10
50081213	3,10		10		10
50081214	3,51		10		10
50081215	3,51		10		10
50081311	3,10		10		10
50081312	3,51		10		10
50081313	3,10		10		10
50081314	3,51		10		10
50081315	3,51		10		10
50082311	3,10		10		10
50082312	3,51		10		10
50082313	3,10		10		10
50082314	3,51		10		10
50082315	3,51		10		10
50082411	3,10		10		10
50082412	3,51		10		10
50082413	3,10		10		10
50082414	3,51		10		10
50082415	3,51		10		10
50084811	3,10		10		10
50084812	3,51		10		10
50084813	3,10		10		10
50084814	3,51		10		10
50084815	3,51		10		10
50101211	3,01		10		11
50101212	3,40		10		11
50101213	3,01		10		11
50101214	3,40		10		11
50101215	3,40		10		11
50101311	3,01		10		11
50101312	3,40		10		11
50101313	3,01		10		11
50101314	3,40		10		11
50101315	3,40		10		11
50102311	3,01		10		11
50102312	3,40		10		11
50102313	3,01		10		11

Cod. Art.	€	Sconfezionabile Unpack	Q. Min	Master	Pag
50102314	3,40		10		11
50102315	3,40		10		11
50102411	3,01		10		11
50102412	3,40		10		11
50102413	3,01		10		11
50102414	3,40		10		11
50102415	3,40		10		11
50104811	3,01		10		11
50104812	3,40		10		11
50104813	3,01		10		11
50104814	3,40		10		11
50104815	3,40		10		11
51101211	3,00		10		7
51101212	3,30		10		7
51101213	3,00		10		7
51101214	3,30		10		7
51101215	3,30		10		7
51101311	3,00		10		7
51101312	3,30		10		7
51101313	3,00		10		7
51101314	3,30		10		7
51101315	3,30		10		7
51102311	3,00		10		7
51102312	3,30		10		7
51102313	3,00		10		7
51102314	3,30		10		7
51102315	3,30		10		7
51102411	3,00		10		7
51102412	3,30		10		7
51102413	3,00		10		7
51102414	3,30		10		7
51102415	3,30		10		7
51104811	3,00		10		7
51104812	3,30		10		7
51104813	3,00		10		7
51104814	3,30		10		7
51104815	3,30		10		7
52.1200.0002	7,98		10		47
52091211	2,94		10		8
52091212	3,23		10		8
52091213	2,94		10		8
52091214	3,23		10		8
52091215	3,23		10		8
52091311	2,94		10		8
52091312	3,23		10		8
52091313	2,94		10		8
52091314	3,23		10		8
52091315	3,23		10		8
52092311	2,94		10		8
52092312	3,23		10		8
52092313	2,94		10		8
52092314	3,23		10		8
52092315	3,23		10		8
52092411	2,94		10		8
52092412	3,23		10		8
52092413	2,94		10		8

Cod. Art.	€	Sconfezionabile Unpack	Q. Min	Master	Pag
52092414	3,23		10		8
52092415	3,23		10		8
52094811	2,94		10		8
52094812	3,23		10		8
52094813	2,94		10		8
52094814	3,23		10		8
52094815	3,23		10		8
52650	6,00		6	48	105
52660	6,00		6	48	105
52675	13,35	si - yes	12		105
5314	1,04		25		20
5320	0,70		25		20
5320.110	0,45		50		20
55142	1,19		25		34
56101211	3,27		10		12
56101212	3,70		10		12
56101213	3,27		10		12
56101214	3,70		10		12
56101215	3,70		10		12
56101311	3,27		10		12
56101312	3,70		10		12
56101313	3,27		10		12
56101314	3,70		10		12
56101315	3,70		10		12
56102311	3,27		10		12
56102312	3,70		10		12
56102313	3,27		10		12
56102314	3,70		10		12
56102315	3,70		10		12
56102411	3,27		10		12
56102412	3,70		10		12
56102413	3,27		10		12
56102414	3,70		10		12
56102415	3,70		10		12
56104811	3,27		10		12
56104812	3,70		10		12
56104813	3,27		10		12
56104814	3,70		10		12
56104815	3,70		10		12
58118	1,22		25		34
58121	31,95	si - yes	12	48	100
58128	1,22		25		34
58380	38,80	si - yes	6	24	100
58500	24,45	si - yes	12	48	97
58534	24,45	si - yes	10	20	98
58575	24,45	si - yes	12	48	97
58600	21,40	si - yes	16	32	99
58790	6,97		5		21
59007	4,69		5		21
59154.C	1,01		25		35
59171.GD	0,87		20		21
600	116,90		1		63
60101211	3,27		10		13
60101212	3,70		10		13
60101213	3,27		10		13

Cod. Art.	€	Sconfezionabile Unpack	Q. Min	Master	Pag
60101214	3,70		10		13
60101215	3,70		10		13
60101311	3,27		10		13
60101312	3,70		10		13
60101313	3,27		10		13
60101314	3,70		10		13
60101315	3,70		10		13
60102311	3,27		10		13
60102312	3,70		10		13
60102313	3,27		10		13
60102314	3,70		10		13
60102315	3,70		10		13
60102411	3,27		10		13
60102412	3,70		10		13
60102413	3,27		10		13
60102414	3,70		10		13
60102415	3,70		10		13
60104811	3,27		10		13
60104812	3,70		10		13
60104813	3,27		10		13
60104814	3,70		10		13
60104815	3,70		10		13
6015	8,38		12		88
6018	10,45		12		88
60220	0,30		50		36
60250	0,36		50		36
60255	0,36		50		36
60256	0,36		50		36
60257	0,36		50		36
60258	0,36		50		36
60259	0,36		50		36
60260	0,29		50		36
60265	0,29		50		36
60266	0,33		50		36
60720	6,70		12		80
60750	5,75		15		79
60751	26,50		1		79
60753	3,23		25		79
60755	6,60		15		79
60756	29,00		1		79
60757	1,17		10		81
60758	1,42		10		81
60760	6,84		15		80
60764	3,00		12		80
60770	7,13		12		83
60775	5,75		12		83
60785	5,75		12		84
60791	7,12		12		84
60792	6,12		6		83
60795.B	4,80		12		82
60795.N	4,80		12		82
60795.R	4,80		12		82
60795.XP	56,80		1		82
60800	11,45		12		85
60801	7,31		24		85
60850	9,88		12		82

Cod. Art.	€	Sconfezionabile Unpack	Q. Min	Master	Pag
60860	8,67		12		85
60861	36,45		1		85
60950	19,70		4		86
60950.5	167,95		1		86
60951	11,30	si - yes	12		86
6195.25.02	4,90		10		122
6195.25.05	4,90		10		122
6195.25.06	4,90		10		122
6219.20	57,05		1		62
6219.30	80,45		1		62
6219.40	97,25		1		62
6219.50	118,40		1		62
6219.60	143,40		1		62
623	6,68	si - yes	12		152
6249.25.02	17,10		10		123
6249.25.05	17,10		10		123
6249.25.06	17,10		10		123
6251.25.02	14,95		10		123
6251.25.03	14,95		10		123
6251.25.05	14,95		10		123
6257.25.02	11,65		10		124
6257.25.05	11,65		10		124
6258.25.02	31,55		10		124
6258.25.05	31,55		10		124
6259.25.02	17,70		10		123
6259.25.05	17,70		10		123
6259.25.06	17,70		10		123
6262.25.02	11,25		10		123
6262.25.05	11,25		10		123
6262.25.06	11,25		10		123
6263.25.02	12,70		10		124
6263.25.13	12,70		10		124
660.958	0,53		100		31
66101211	3,37		10		14
66101212	3,81		10		14
66101213	3,37		10		14
66101214	3,81		10		14
66101215	3,81		10		14
66101311	3,37		10		14
66101312	3,81		10		14
66101313	3,37		10		14
66101314	3,81		10		14
66101315	3,81		10		14
66102311	3,37		10		14
66102312	3,81		10		14
66102313	3,37		10		14
66102314	3,81		10		14
66102315	3,81		10		14
66102411	3,37		10		14
66102412	3,81		10		14
66102413	3,37		10		14
66102414	3,81		10		14
66102415	3,81		10		14
66104811	3,37		10		14
66104812	3,81		10		14
66104813	3,37		10		14

Cod. Art.	€	Sconfezionabile Unpack	Q. Min	Master	Pag
66104814	3,81		10		14
66104815	3,81		10		14
666.001	1,46		100		31
666.002	1,46		100		31
666.003	1,46		100		31
68.06.040	0,71		50		20
68.48.020	0,76		50		20
681.U	4,79	si - yes	20		169
681.942	0,90		25		31
691.178.C	2,07		50		32
691.180.C	2,07		50		32
691.182.C	2,07		50		32
691.185.C	2,07		50		32
691.186.C	2,07		50		32
692.177.C	2,07		50		32
692.179.C	2,07		50		32
692.181.C	2,07		50		32
692.183.C	2,07		50		32
693	10,70	si - yes	10		151

705.6	1,97		1		91
711.950.C	2,89		20		32
711.980.C	2,89		20		32
711.982.C	2,89		20		32
711.984.C	2,89		20		32
711.986.C	2,89		20		32
78015.KIT	13,00		1		92
78318	15,95	si - yes	10		89
7840	8,29	si - yes	10		92
7957	7,78	si - yes	12	48	159

8100.34.16	1,08		50		114
8102.34.16	1,24		50		114
811.956.C	5,38		20		32
811.980.C	5,38		20		32
811.982.C	5,38		20		32
811.984.C	5,38		20		32
811.985.C	5,38		20		32
8200.34.36.B	1,37		50		114
8200.34.36.R	1,42		50		114
8200.34.36.V	1,42		50		114
8300.34.16	1,12		50		114
830016	2,35		50		113
830037	2,52		50		113
8302.34.16	1,24		50		114
8305.34.00	1,35		50		114
836	6,65	si - yes	12		153
839	9,17		6		153
840038	2,52		50		113
8500.34.00	2,56		25		114
8650.34.36.R	2,26		25		115
8650.34.36.R.PV	3,12		100		115
8650.34.36.V	2,26		25		115
8650.34.36.V.PV	3,12		100		115
8750.34.00	1,73		25		115
8752.34.00	1,81		25		115

Cod. Art.	€	Sconfezionabile Unpack	Q. Min	Master	Pag
8755.34.00	2,01		25		115

900.USB	13,30	si - yes	10	40	176
9000.34	0,93		50		116
9001.34	1,52		50		116
9002.34	1,10		50		116
9004.34.R	1,01		25		117
9004.34.VF	1,53		25		117
9005.34	1,03		25		117
9010.34.R	1,44		25		117
9010.34.VF	1,83		25		117
903.USB	6,74	si - yes	12	48	176
907	5,34		12		150
9072	3,67		12		163
94.14.080	0,25		100		20
94.60.020	0,40		100		20
967	4,92	si - yes	12		158
9702	19,00	si - yes	12		167
9788	3,03		24	144	160
980.S	3,00		25		112
989L	2,95		24		164
991.EUP	9,33	si - yes	50		168
992.EUP	15,80	si - yes	20		168
997.EUP	11,25	si - yes	20		168

In ottemperanza a quanto richiesto dalle normative europee vigenti, ARTELETA esegue meticolose prove e controlli su tutti i propri prodotti. Ecco le principali direttive che riguardano i prodotti elettrici, i corpi illuminanti e gli apparecchi d'illuminazione.

Le direttive del settore elettrico



La legislazione europea in materia di impiantistica elettrica in bassa tensione è composta da due direttive di prodotto:

- Direttiva **2014/35/EU** (ex 73/23 - 93/68) sulla Bassa Tensione e la sicurezza del materiale elettrico.
- Direttiva **2014/30/EU** CE (ex 89/336) sulla Compatibilità Elettromagnetica.

In base a queste direttive il costruttore, o l'importatore, è obbligato ad apporre sul prodotto la marcatura CE. In questo modo dichiara la rispondenza del medesimo prodotto alle normative europee armonizzate (EN).

Sui nostri cataloghi sono stati evidenziati con il marchio CE tutti quei prodotti ai quali vanno applicate le direttive sopra citate e che sono rispondenti alle direttive medesime.

Salvo errori di stampa, per i prodotti che non recano la marcatura CE non sono applicabili le direttive menzionate.

DIRETTIVA RAEE:

Rifiuti di Apparecchiature Elettriche ed Elettroniche

D. Lgs n°49/2014 in attuazione della direttiva europea 2012/19/EU.

Per adempiere a questi obblighi di legge ARTELETA INTERNATIONAL S.p.A. ha deciso di avvalersi del supporto del Consorzio **ECOLIGHT** Via Monte Rosa, 96 - 20149 Milano - Tel. 02.33600732 - www.ecolight.it

I prodotti contrassegnati dal simbolo  saranno soggetti allo smaltimento differenziato secondo quanto indicato dalla legge.

Gli utenti finali potranno consegnare i nostri apparecchi presso i punti raccolta appositamente realizzati, e comunicati dal Consorzio, senza costi aggiuntivi.

In compliance with the requirements of the European directives in force, ARTELETA performs strict tests and checks on all its products. Here are the main directives that concern electrical products, luminaires and lighting appliances.

Electrical sector directives



The European laws on low voltage electrical installations consist of two product directives:

- Directive **2014/35/EU** (formerly 73/23 - 93/68) on Low Voltage and electric material safety.
- Directive **2014/30/EU EC** (formerly 89/336) on Electromagnetic Compatibility.

Based on these directives the manufacturer, or importer, is obliged to affix the CE marking on the product. In this way they declare compliance of the same product with the harmonised European regulations.

On our catalogues, all products to which the above mentioned directives are applied and which comply with them, are highlighted with the CE mark.

Except printing errors, the above mentioned directives are not applicable for the products that do not bear the CE marking.

WEEE DIRECTIVE:

Waste Electrical and Electronic Equipment

Legislative decree n° 49/2014 in transposition of European directive 2012/19/EU.

*To fulfil these legal obligations, ARTELETA INTERNATIONAL S.p.A. has decided to rely on the support of the **ECOLIGHT** Consortium Via Monte Rosa, 96 - 20149 Milan - Ph. 02.33600732 - www.ecolight.it*

The products marked with the symbol  will be subject to separate disposal according to the provisions of the law.

Final users can deliver our appliances at the suitable collection points, as notified by the Consortium, with no additional costs.

DIRETTIVA RoHS 2

Il 04.01.2013 è entrata in vigore la nuova Direttiva Europea 2011/65/CE anche conosciuta come RoHS2, sempre riguardante i limiti d'uso di alcune sostanze pericolose.

A partire da tale data tutte le nuove apparecchiature elettriche ed elettroniche immesse sul mercato non dovranno contenere o contenere in misura limitata sostanze quali:

- Piombo
- Cromo esavalente
- Mercurio
- Bifenile polibromurati (PBB)
- Cadmio
- Eteri difendi polibromurati (PBDE)

Questa direttiva impone che nelle dichiarazioni di conformità CE vengano ricomprese anche le prescrizioni relative a questa direttiva. A far data da gennaio 2013 le nostre dichiarazioni di conformità CE conterranno anche la conformità a detta direttiva.

ARTELETA ha deciso di utilizzare comunque questi marchietti per evidenziare la conformità dei propri prodotti a questa direttiva.



RoHS 2 DIRECTIVE

The new European Directive 2011/65/EC, also known as RoHS2, came into force on 04.01.2013, also concerning the restrictions of use of certain hazardous substances.

Starting from this date all the new electrical and electronic equipment placed on the market must not contain or contain to limited extent substances such as:

- Lead
- Hexavalent chromium
- Mercury
- Polybrominated biphenyl (PBB)
- Cadmium
- Polybrominated diphenyl ethers (PBDE)

This directive sets forth that requirements relating to this directive should be included in CE declarations of conformity. As of January 2013 our CE declarations of conformity also contain conformity to said directive.

ARTELETA has decided to use these marks in any case to highlight its products' conformity to this directive.



NORMATIVA REACH

La normativa europea Reach n. 1907/2006 riguarda gli obblighi da parte del fornitore di segnalare la presenza nei propri prodotti di 15 sostanze giudicate altamente pericolose per la salute. Tale presenza deve essere in una concentrazione non superiore allo 0,1% in peso.

In ottemperanza a quanto prescritto dalla presente normativa, ARTELETA INTERNATIONAL S.p.A. dichiara che nessuno dei propri prodotti contiene una o più delle sostanze indicate nella normativa.

DIRETTIVA PFOS

La direttiva 2006/122/EC impone ai produttori la limitazione e/o la sospensione dell'utilizzo di PERFLUOROOTTANO SULFONATI (PFOS) poiché pericolosi per la salute.

Al fine di ottemperare a quanto prescritto dalla normativa comunitaria, ARTELETA INTERNATIONAL S.p.A. dichiara che nessuno dei propri prodotti contiene PFOS.

REACH REGULATION

The European Reach regulation no. 1907/2006 concerns obligations by the supplier to notify of the presence in its products of 15 substances deemed as highly hazardous to health. This presence must be in a concentration not higher than 0.1% in weight.

In compliance with the provisions of this regulation, ARTELETA INTERNATIONAL S.p.A. declares that none of its products contains one or more of the substances specified in the regulation.

PFOS DIRECTIVE

Directive 2006/122/EC imposes on manufacturers the limitation and/or discontinuation in the use of PERFLUOROOTTANE SULFONATES (PFOS) as they are hazardous to health.

In order to comply with the provisions of the EC regulation, ARTELETA INTERNATIONAL S.p.A. declares that none of its products contains PFOS.

Le direttive europee del settore illuminazione

European directives in the lighting sector

SICUREZZA FOTOBIOLOGICA:
EN 62471:2009

PHOTO-BIOLOGICAL SAFETY:
EN 62471:2009

Questa norma riguarda la valutazione delle apparecchiature illuminotecniche relativamente all'esposizione umana alle radiazioni ottiche artificiali.

Tale norma è entrata in vigore il 01.02.2013.

Come indicato da IMQ e dal comitato europeo competente, i led per uso illuminazione ricadono tutti nei gruppi di rischio esente e gruppo 1 ritenuti non pericolosi per la salute.

Possiamo pertanto affermare che i nostri led assolvono pienamente i requisiti della norma in oggetto.

This standard concerns the assessment of lighting appliances with regards to human exposure to artificial optical radiation.

This standard came into force on 01.02.2013.

As indicated by IMQ and by the competent European committee, LEDs for lighting use all fall within the exempt risk group and group 1 deemed as non hazardous to health.

We may therefore state that our LEDs fully comply with the requirements of the standard in question.

DIRETTIVA ERP

ERP DIRECTIVE

Progettazione ecocompatibile.

La direttiva 2009/125/CE è volta a ridurre il consumo di energia degli apparecchi sin dalla fase della loro progettazione. Per quanto riguarda la nostra gamma prodotti, in particolar modo su talune categorie di lampade, si applicano i regolamenti 244/2009 e 874/2012 che impongono una nuova etichettatura energetica.

I prodotti Arteleta recano il nuovo tipo di etichettatura e rispondono ai requisiti imposti dalla sopracitata direttiva.

Per esigenze grafiche sul presente catalogo (solo sul catalogo non sui prodotti) è stato utilizzato un simbolo grafico meno "invasivo" dell'originale etichetta. Rimangono invariati le prove ed i controlli necessari per approvare la corretta indicazione.

Eco-compatible design.

Directive 2009/125/EC is aimed at reducing energy consumption of appliances as of their design stage. With regards to our product range, especially in certain lamp categories, regulations 244/2009 and 874/2012 are applicable, which impose new energy labelling. Arteleta products bear the new type of labelling and comply with the requirements set by the above mentioned directive. Due to graphic needs, on this catalogue (only on the catalogue, not on the products) a less "invasive" graphic symbol has been used compared to the original label. The tests and checks required to approve the correct indication remain unchanged.



RESI IN GENERALE

Secondo la vigente normativa di legge la merce resa dovrà essere accompagnata dal Documento di Trasporto che deve riportare obbligatoriamente gli estremi della bolla o della fattura di acquisto. **L'omissione di tali dati non ci consentirà di accettare il reso.**

È importante richiedere prima al rappresentante della zona autorizzazione al reso dei prodotti che si desidera rendere.

Qualora la richiesta rientri nel termine della garanzia, sarà comunicato il numero di autorizzazione al reso.

I resi di materiale verranno accettati a valore pieno di acquisto solo per giustificato motivo purchè entro 8 giorni dalla consegna del materiale e comunque non oltre l'ultimo giorno del mese solare corrente.

Il reso inoltre dovrà essere effettuato in **porto franco**.

Diversamente verranno applicati i seguenti criteri di valutazione:

- entro 30 gg. dal termine suddetto: -10%
- entro 60 gg. dal termine suddetto: -20%
- oltre 60 gg. da concordare di volta in volta con il rappresentante di zona.

Il reso di prodotti **non di nostra provenienza** verrà immediatamente rinvio in porto assegnato con l'addebito automatico di € 50,00 per spese amministrative forfetarie.

RESI IN GARANZIA

I resi in garanzia si intendono tutti quei prodotti resi entro il termine della garanzia riportata sui singoli apparecchi i quali dovranno pervenire in **porto franco** al nostro domicilio di Cinisello Balsamo. I ritorni dovranno essere accompagnati dalla cartolina di garanzia timbrata dal rivenditore.

I prodotti non devono risultare manomessi, nel qual caso la garanzia decade.

Da parte nostra si procederà come segue:

- sostituzione gratuita dell'apparecchio, se **reso entro il termine di garanzia**
- sostituzione con nuovo apparecchio con addebito del 50% del costo se la garanzia è scaduta e se l'apparecchio si presenta riparabile.

Apparecchi di data superiore a 24 mesi saranno solo riparati, se possibile, addebitando il costo della riparazione e delle parti di ricambio.

ARTELETA INTERNATIONAL SPA si fa carico di eventuali difetti del prodotto, ma non **assume nessuna responsabilità** per errato utilizzo e/o inidonea installazione del prodotto.

RESI AUTORIZZATI E DOCUMENTI RELATIVI (documento di trasporto addebiti/fatture) dovranno essere indirizzati alla sede commerciale

ARTELETA INTERNATIONAL S.p.A.
Via Pellizza da Volpedo, 57
20092 Cinisello Balsamo (MI)

RETURNS IN GENERAL

*Under current legal regulations the returned goods must be accompanied by the Transport Document which must compulsorily contain the details of the delivery note or invoice. **Failure to provide said data does not allow us to accept the return.***

It is important first to ask the area representative for the authorisation to return the products you intend to return.

If the request fall within the terms of the warranty, the return authorisation number will be notified.

The returns of material are accepted at full purchase value only for reasoned grounds provided within 8 days from delivery of the material and, in any case, not over the last day of the current solar month.

*Furthermore the return shall be made **carriage free**.*

Otherwise the following assessment criteria shall be applied:

- within 30 dd. from the above term: -10%
- within 60 dd. from the above term: -20%
- over 60 dd. to be agreed from time to time with the area representative.

*The return of products **not of our origin** will be immediately returned carriage forward with automatic debit of € 50.00 for flat rate administrative expenses.*

RETURNS UNDER WARRANTY

Returns under warranty refer to all those products returned within the terms of the warranty specified on individual appliances which must be received carriage free at our address in Cinisello Balsamo. The products must not be tampered with, in which case the warranty is forfeited.

On our part, we shall proceed as follows:

- appliance replacement free of charge, **if returned within the warranty terms**
- replacement with new appliance with 50% debit of the cost if the warranty has expired and the appliance appears to be repairable.

Appliances with date over 24 months shall only be repaired, if possible, by debiting the cost of the repair and of spare parts.

ARTELETA INTERNATIONAL SPA undertakes liability for any product defects, but disclaims any liability for incorrect use and/or unsuitable installation of the product.

AUTHORISED RETURNS AND RELATING DOCUMENTS (transport document debits/invoices) shall be addressed to the sales office

ARTELETA INTERNATIONAL S.p.A.
Via Pellizza da Volpedo, 57
20092 Cinisello Balsamo (MI)



Arteleta International S.p.A. - Head Office and Warehouses
20092 Cinisello Balsamo (MI) - Via Pellizza da Volpedo, 57
Tel. 0039-02-66013541 r.a. - Fax 0039-02-6122573
E-mail: info@arteleta.it - www.arteleta.it

Premessa: la nostra società operando in prevalenza con l'estero, si riserva il diritto di apportare in qualsiasi momento delle variazioni alle normali condizioni di vendita commerciali in seguito ad eventuali fenomeni valutari.

Premise: since our company mainly operates with foreign countries, we reserve the right to make changes at any time to the normal sale conditions following any currency phenomena.

① **IMPEGNI**

Tutte le proposte d'ordine si intendono assunte con la clausola "salvo approvazione della casa" e saranno vincolanti per la ARTELETA INTERNATIONAL S.p.A. solo dopo la restituzione della conferma d'ordine sottoscritta dal committente per accettazione.

La mancata accettazione dell'ordine da parte della ARTELETA INTERNATIONAL S.p.A. non dà luogo a nessuna pretesa del compratore, per nessun titolo, ragione o causa.

Gli accordi e le intese con agenti, rappresentanti, ecc. hanno solamente valore di trattativa.

② **PREZZI**

I prezzi quotati nei listini, nelle offerte e nelle conferme d'ordine non sono impegnativi e possono essere aggiornati secondo i costi vigenti il giorno della spedizione. Inoltre, a causa della fluttuazione dei cambi, ci riserviamo di addebitare o accreditare al momento della fatturazione la differenza nel caso la variazione sia il $\pm 3\%$ del cambio indicato sul listino prezzi. Noi daremo comunicazione al compratore il quale avrà facoltà di annullare l'ordine entro 10 gg. dalla data di spedizione della comunicazione. Trascorso tale termine, il compratore resterà impegnato ad accettare le variazioni.

③ **CONSEGNE**

I termini di consegna non sono impegnativi.

Il compratore non può pretendere annullamenti parziali o totali dell'ordine, nè rifusione di danni nel caso di ritardi o di riduzioni delle forniture dovuti a cause di forza maggiore.

Ci riserviamo di annullare tutto o in parte l'ordine conferitoci qualora la fornitura del materiale ordinato fosse resa difficile o impossibile da circostanze speciali di qualsiasi natura. In tale caso non ci incomberà alcun obbligo di risarcire i danni o di fornire il materiale più tardi, ancorché dette circostanze abbiano cessato di esistere.

Eventuali scioperi, guerre, epidemie, interruzioni ferroviarie, scarsità di materiali, difficoltà di rifornimento e quante altre cause potessero obbligarci a sospendere le consegne, si intenderanno come casi di forza maggiore che autorizzeranno la sospensione dell'esecuzione dei contratti.

④ **QUANTITATIVI**

I quantitativi possono essere diminuiti senza preavviso secondo le ns. disponibilità e verranno modificati secondo le confezioni originali per facilitare l'imballaggio.

⑤ **IMBALLAGGIO**

Viene fatturato all'1%, salvo diversi accordi, e non si accetta di ritorno.

⑥ **SPEDIZIONI**

La merce viene resa franco nostro magazzino sia per acconti che per saldi, e viene spedita con il mezzo di trasporto indicato dal compratore. In mancanza di tale indicazione, avremo la facoltà di scegliere il mezzo che reputiamo più conveniente, senza assumere responsabilità alcuna. **La merce viaggia sempre a rischio e pericolo del compratore** anche se trattasi di fornitura assunta con la condizione di resa franco destino.

Non rispondiamo quindi di alcun reclamo, nè per mancanza di peso, nè per avarie che possono essere avvenute durante il trasporto od al momento dello scarico: di ciò saranno responsabili i vettori verso i quali il destinatario dovrà svolgere le pratiche del caso, prima del ritiro della merce.

⑦ **FATTURAZIONE**

Per esigenze di costi generali non si possono accettare ordini con importo fatturabile netto inferiore a € 260,00, o verranno addebitate € 13,00 quale contributo spese di amministrazione.

⑧ **RECLAMI**

Gli eventuali reclami per difetti della merce decadono dopo 30 gg. dall'arrivo della stessa a destino. La merce difettosa dovrà essere resa al nostro indirizzo in porto franco.

① **COMMITMENTS**

All proposed orders shall be deemed as undertaken with the clause "subject to the house's approval" and shall be binding for ARTELETA INTERNATIONAL S.p.A. only after returning the order confirmation signed by the customer by acceptance.

Failure to accept the order by ARTELETA INTERNATIONAL S.p.A. does not give rise to any claim of the buyer, under any title, reason or cause.

The agreements with agents, representatives, etc. only have negotiation value.

② **PRICES**

The prices listed on price lists, offers and order confirmations are not binding and may be updated according to the costs in force on the shipping day. Furthermore, due to exchange rate fluctuations, we reserve the right to debit or credit the difference upon invoicing, in case that exchange rate should be $\pm 3\%$ of the price indicated in the price list. The buyer shall be notified and be entitled to cancel the order within 10 dd. from the date of sending the notice. After said period, the buyer shall be committed to accepting the changes.

③ **DELIVERIES**

The delivery terms are non binding.

The buyer may not demand partial or total cancellations of the order, nor compensation for damage in the event of delays or reductions in the deliveries due to force majeure.

We reserve the right to cancel all or part of the order sent to us if the supply of the ordered material was made difficult or impossible by special circumstances of any kind. In that case we shall not incur any obligation to compensate for damage or to supply the material at a later date, although said circumstances have ceased to exist.

Any strikes, wars, epidemics, railway interruptions, shortages of materials, procurement difficulties, and any other causes could force us to suspend deliveries, shall be considered as cases of force majeure, which shall authorise the discontinuation of the contracts.

④ **QUANTITY**

The amounts may be decreased without prior warning according to our availability and shall be modified according to the original packages for easier packaging.

⑤ **PACKAGING**

It is invoiced at 1%, unless otherwise agreed, and is not accepted in return.

⑥ **SHIPMENTS**

The goods are delivered ex our warehouse both for advance shipments and settlements, and are shipped with the means of transport indicated by the buyer. Failing said indication, we shall be entitled to choosing the means we deem the most expedient, without undertaking any liability. **The goods always travel at the buyer's risk** even if the supply is with delivery condition of prepaid transportation.

Therefore we shall not be liable for any claims, nor for deficiency in weight, nor for damage which may have occurred during transport or when unloading: the carriers shall be responsible for that, towards which the recipient shall carry out the practices of the case before withdrawing the goods.

⑦ **INVOICING**

Due to general cost needs no orders may be accepted with net invoicing value lower than € 260.00, or € 13.00 shall be debited as a contribution towards administration expenses.

⑧ **COMPLAINTS**

Any complaints for defects in the goods shall be forfeited after 30 dd. from arrival of the same at destination. The defective goods shall be returned to our address carriage free.

Salvo patto contrario specificatamente accettato da noi per iscritto, valgono unicamente le presenti nostre condizioni, che pertanto annullano e sostituiscono le condizioni di acquisto dell'acquirente senza obbligo di nostra contestazione scritta. Qualsiasi accordo verbale o telefonico è senza impegno.

9 RESI DI MERCE

Desiderando sempre rendere soddisfatto il compratore, accettiamo di ritorno **la nostra merce**. Sostituiamo la merce corrispondente al vigente catalogo, sempre che non risulti usata, deteriorata od inservibile per evidenti segni di tentata riparazione. Le spese di trasporto fino al nostro magazzino sono sempre a carico dell'acquirente. La merce resa dovrà essere accompagnata da ufficiale bolla di accompagnamento sulla quale è necessario indicare anche il riferimento della fornitura (numero fattura, data, ecc.) secondo le vigenti disposizioni fiscali. **Resi di merci per errore di ordinazione o per motivo non imputabile a noi, saranno accettati solo se preventivamente autorizzati e se saranno spediti in porto franco. La merce relativa, se sarà riscontrata in perfetto stato, sarà accreditata nel valore fatturato, meno il 10% quale concorso spese riguardanti le operazioni di controllo, reimmagazzinaggio, amministrative.**

10 MODELLI E DIMENSIONI

Ci riserviamo il diritto di cambiare forma, disegno e dimensioni dei vari modelli illustrati sul presente catalogo.

11 PAGAMENTI

I pagamenti sono riconosciuti validi solo se fatti direttamente al nostro domicilio di Cinisello Balsamo.

Trascorsi 30 gg. dalla data fattura, si consiglia di astenersi dalla rimessa diretta in quanto sarà già in circolazione la relativa tratta a saldo con valuta 60 gg. data fattura. Le eventuali spese di insoluto sarebbero a carico del Cliente.

Non corrispondiamo interessi sulle somme anticipate. Sui pagamenti scaduti, decorrono gli interessi d'uso per i crediti bancari. Questo per altro non conferisce al committente alcun diritto a dilazionare il pagamento. In caso di inadempimento, ci riserviamo il diritto di annullare l'intera ordinazione conferitaci, oppure la parte non ancora evasa, e nel contempo di esigere l'immediato pagamento del materiale già fornito. Non è riconosciuto il pagamento fatto ai nostri agenti o rappresentanti, a meno che essi non siano regolarmente autorizzati con mandato, portante la nostra firma.

N.B. In caso di pagamento con Ricevuta Bancaria, qualora la stessa ci ritorni insoluta, Vi saranno addebitate € 15,00 per costi gestione insoluto.

12 RISERVA DI PROPRIETÀ

La consegna del nostro materiale si intende fatta ed accettata con il patto di nostro riservato dominio fino al totale assolvimento degli obblighi di pagamento con noi pendenti.

Qualsiasi accordo non conforme alle nostre condizioni generali di vendita è impegnativo solo se convenuto anticipatamente per iscritto e se espressamente accettato e confermato posteriormente per iscritto.

13 FORO COMPETENTE

Per qualunque controversia inerente l'interpretazione, l'esecuzione e la risoluzione del presente contratto di fornitura di merce è competente il Foro di Milano, che le parti concordemente eleggono quale Foro esclusivo, derogando espressamente alla competenza di tutti gli altri fori concorrenti.

14 PRIVACY - Informativa ai sensi dell'art. 13 del D.lgs 196/03

I dati forniti saranno trattati, con Vs. consenso, esclusivamente per scopi commerciali per consentire l'evasione di ordini e relativi adempimenti contabili.

I dati saranno trattati su supporto informatico o cartaceo e non verranno comunicati a terzi, fatto salvo agli Istituti bancari per l'eventuale gestione degli incassi.

Viene riconosciuto l'esercizio dei diritti di cui all'art. 7 in particolare a richiedere la fonte dei dati, l'aggiornamento, la rettifica o la cancellazione. Il titolare dei dati è Arteleta International S.p.A. via Pellizza da Volpedo, 57 - 20092 Cinisello Balsamo (MI), che si avvale per il trattamento dei dati dei propri dipendenti e collaboratori che sono stati incaricati allo scopo.

Unless specifically otherwise agreed by us in writing, our conditions shall be solely applicable, which therefore repeal and supersede the buyer's purchase conditions with no obligation of written objection on our part. Any verbal or telephone agreement is non binding.

9 RETURNED GOODS

As it is our wish to always satisfy the buyer, we accept our returned goods. We shall replace the corresponding goods as per catalogue in force, provided it is not worn, deteriorated or unusable due to obvious marks of tampering and attempted repairs. Transport expenses to our warehouse are always borne by the buyer. The returned goods shall be accompanied by official transport note on which it is required to indicate also the supply references (invoice number, date etc.) according to current tax regulations.

Returns of goods for ordering errors or for reasons not attributable to us shall only be accepted if authorised prior and shall be shipped carriage free. The relevant goods, if found in perfect condition, shall be credited in the invoiced value, less 10% as a contribution towards expenses concerning inspection, re-warehousing and administration.

10 MODELS AND DIMENSIONS

We reserve the right to change the shape, design and dimensions of the various models illustrated in this catalogue.

11 PAYMENTS

Payments are acknowledged as valid only if made directly to our address in Cinisello Balsamo.

After 30 dd. from the invoice date, it is recommended to abstain from making a direct transfer since the relevant bankers' draft in settlement will already be circulating with value date 60 dd. from invoice date. Any overdue expenses shall be borne by the Customer.

We do not pay any interest on advance sums. The usual interest for bank credits shall be applied on expired payments. However, this does not in any way authorise the customer to defer payment. In the event of default, we reserve the right to cancel the entire order sent to us, or the part not yet processed, and at the same time to demand immediate payment of the already supplied material. Payment to our agents or representatives is not acknowledged, unless they are duly authorised with a mandate, bearing our signature.

Note: In the event of payment with Bank Order, should the same be returned in suspense, you shall be debited € 15.00 for past due management costs.

12 RETENTION OF TITLE

The delivery of our material shall be made and accepted with the agreement of our reservation of title until complete fulfilment of payment obligations with us. Any agreement not conforming with our general sale conditions shall only be binding if agreed on prior in writing and if expressly accepted and confirmed afterwards in writing.

13 COURT OF JURISDICTION

For any dispute concerning the interpretation, execution and termination of this contract for the supply of goods, the Court of Milan shall have jurisdiction, which the parties unanimously indicate as the exclusive Court, in derogation expressly to the jurisdiction of all other available courts.

14 PRIVACY - Information pursuant to art. 13 of Legislative Decree 196/03

The data supplied shall be processed with your agreement, exclusively for commercial purposes to permit processing orders and relevant accounting fulfilments.

The data shall be processed on IT media or paper and shall not be disclosed to third parties, except for Banking Institutions for managing any cash collections.

The rights under art. 7 are acknowledged, in particular the right to request the source of the data, updating, rectification or cancellation. The holder of the data is Arteleta International S.p.A. via Pellizza da Volpedo, 57 - 20092 Cinisello Balsamo (MI), which makes use of its specifically appointed employees and consultants for processing the data.

NOTE

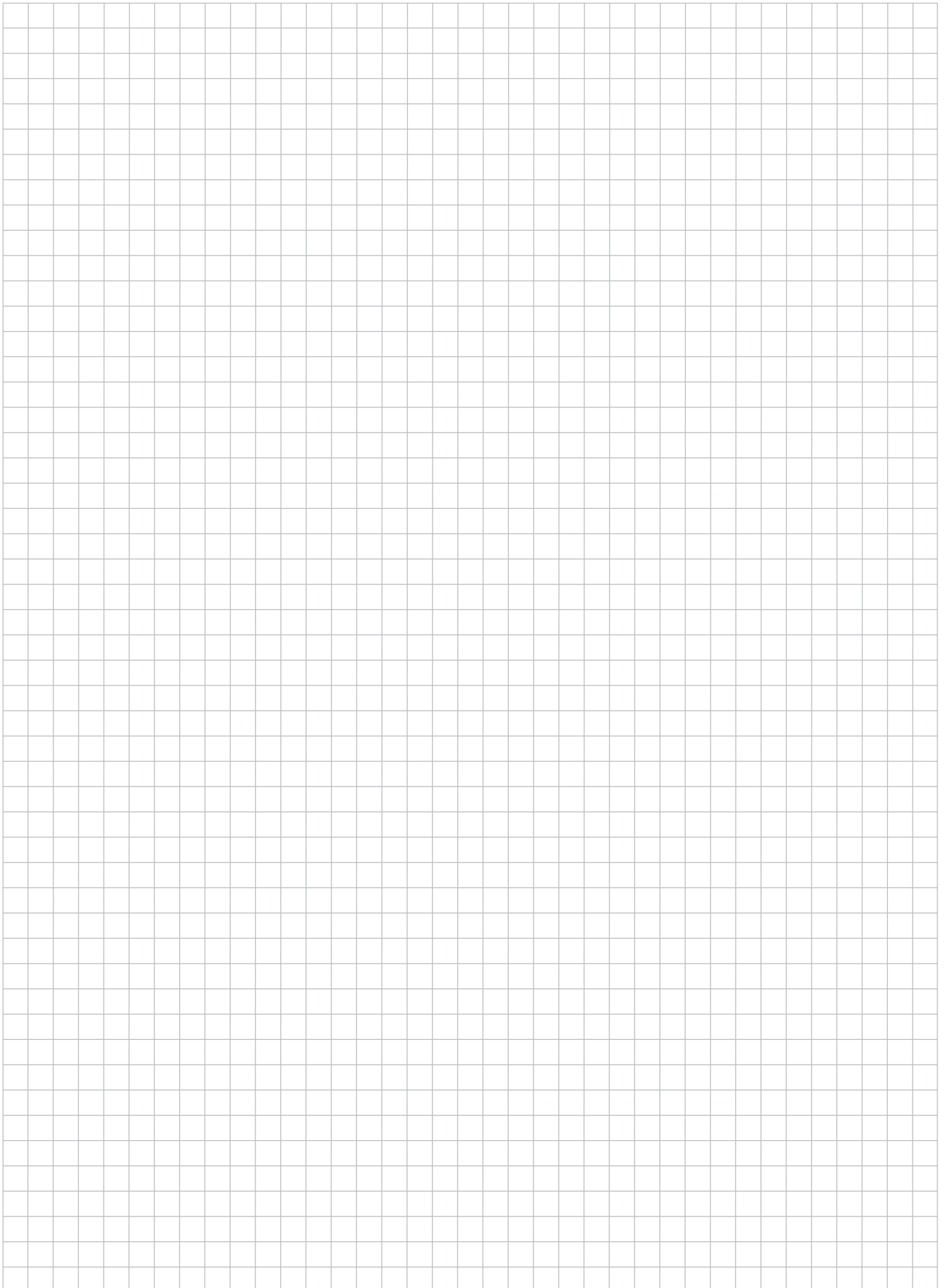

Lombardia, Novara, Verbania, Piacenza
 VOLTA MAURO
 Viale De Gasperi, 25
 26013 CREMA
 tel. 0373.20.40.19
 fax 0373.20.40.22
 agenzia@maurovolta.it

Piemonte
 (escluso Novara, Verbania)
 TRIPALDI ETORE
 Corso Agnelli, 72
 10137 TORINO
 tel. 011.96.46.445
 ettoretripaldi@gmail.com

Liguria
 AGENZIA ROSINI
 ELETTORAPPRESENTANZE
 Via De Mari, 2
 16157 GENOVA
 tel. 010.86.91.868 - cell. 348.73.41.062
 fax 010.86.30.118
 rosinimarco@hotmail.com

Veneto Friuli Venezia Giulia Trentino Alto Adige
 ARES snc
 Via Panà, 56/b
 35027 NOVENTA PADOVANA (PD)
 tel. 049.71.72.37
 fax. 049.73.87.846
 agenzia@arimet.it

Emilia Romagna
 (escluso Piacenza)
 JUST IN TIME
 di Dr. Paolo Cervi
 Via Carlo Mayr, 52
 44121 FERRARA
 tel. 0532.73.36.75 - cell. 335.60.65.244
 fax 0532.73.36.55
 info@eurojust.it

Toscana
 VUERRE srl
 Viale Romana, 149/G
 52100 AREZZO
 tel. 0575.90.15.23
 fax 0575.90.15.23
 info@vuerre.net

Marche Umbria
 GALEAZZI STEFANO
 Via Togliatti, 37/C
 60131 ANCONA
 cell. 348.38.35.816
 fax 071.71.08.001
 sgaleazzi71@gmail.com

Sardegna
 NONNIS RAPPRESENTANZE snc
 Via A. Vincentelli, 28
 07020 LOIRI PORTO SAN PAOLO (OT)
 tel. 0789.41.001- cell. 333.20.80.673
 fax 0789.41.001
 gnonnis@tiscali.it

Lazio
 TEDESCHI MARCO & C. SNC
 Via Cogoletto, 137
 00168 ROMA
 tel. 335.13.58.561
 fax 06.35.50.53.24
 marco_tedeschi@hotmail.com

Campania, Potenza
 ELVETICO RAPPRESENTANZE snc
 di MASSIMO ELVETICO & C.
 Via Plinio, 16 - P.co Leone, Lotto 6
 80013 Casalnuovo (NA)
 tel. 081.52.28.660
 fax 081.52.28.660
 elvetico@elvetico.net

Abruzzo Molise
 CANDELORI CARLO RAPPRESENTANZE ELETTROTECNICHE
 Via F. Petrarca, 13
 64025 PINETO (TE)
 tel. 348.23.21.657
 fax. 178.22.33.697
 info@candelorirappresentanze.com

Puglia, Matera
 P.i. DI TULLIO GIANPAOLO
 V.le Einaudi, 29 - 70125 BARI
 tel. 080.50.19.460
 fax 080.50.19.460
 ditgianp@libero.it

Calabria
 AGENZIA MURDOCCA di Larosa Rosanna
 Via Garibaldi, 7
 89042 GIOIOSA JONICA (RC)
 tel. 0964.51.419 - cell. 337.20.02.47
 fax 0964.51.419
 r.larosa@agenziamurdocca.com

Sicilia Orientale Province: ME - CT - SR RG - EN
 COSTA RICCARDO
 Via Milazzo, 42 - 95030 MASCALUCIA (CT)
 tel. 095.98.91.129 - cell. 393.33.40.556
 fax 095.98.91.164
 progettinluce@progettinluce.com

Sicilia Occidentale Province: PA - TP AG - CL
 PISCITELLO PIETRO
 Via Dionisio, 10 - 90151 PALERMO
 cell. 388.11.44.052
 pietropiscitello@virgilio.it

For foreign countries please refer to Export Department

Tel. 0039-02-66013541 r.a. - Fax 0039-02-6122573

E-mail: acquisti@arteleta.it - www.arteleta.it



Arteleta International S.p.A.
Head Office and Warehouses
20092 Cinisello Balsamo (MI) Italy - Via Pellizza da Volpedo, 57
Tel. 0039-02-66013541 r.a. - Fax 0039-02-6122573
E-mail: info@arteleta.it - www.arteleta.it

Follow us on



Arteleta International S.p.A.



ArteletaInt

Per effettuare il download
di questo catalogo,
inquadrare questo QR
code con la telecamera
del vostro smartphone

*Aim the smart-phone's
camera on the Qr Code
to download the pdf
catalogue*

