

# DOMESTIC FANS

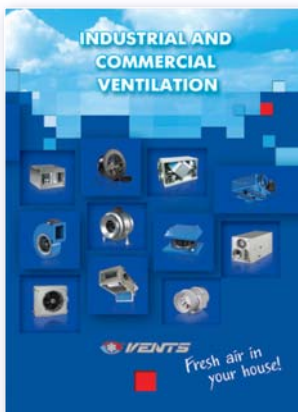

2013

Fresh air in  
your house!



### Industrial and commercial ventilation (Catalogue no. 1)

Industrial and commercial ventilation components - fans for round and rectangular ducts, sound-insulated, axial and roof fans, air handling units with heat recovery, air heating units, accessories.



### Energy saving ventilation Air handling units (Catalogue no. 2)

Energy saving supply and exhaust units and air handling units with heat recovery with air capacity up to 6500 m<sup>3</sup>/h.



### Fire and smoke damper KPDU (Catalogue no. 5)

Fire dampers KPDU for smoke protection systems of buildings and premises.

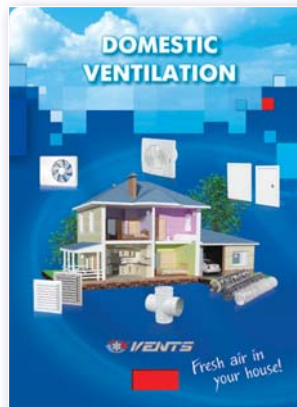

### Domestic ventilation (Catalogue no. 6)

Domestic ventilation: fans, mono-pipe exhaust kitchen and bathroom fans, air distribution units, air ducts and fittings, access doors, ventilation kits.

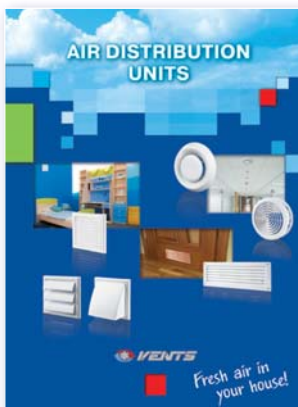

### Air distribution units (Catalogue no. 9)

Plastic and metal air distribution products (grilles, disk valves, diffusers, etc.) for ventilation, air conditioning and heating.

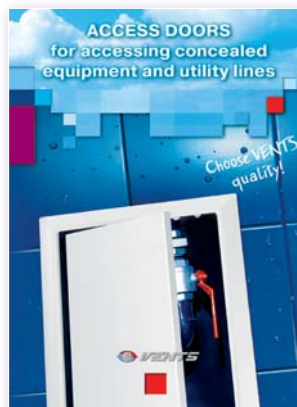

### Access doors (Catalogue no. 10)

Plastic and metal access doors for accessing concealed equipment and utility lines. Special offers for ceramic tiles.

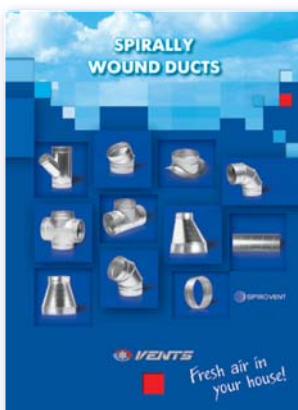

### Spiral seam air ducts (Catalogue no. 13)

SPIROVENT spiral seam vent ducts and fittings of 100 to 1600 mm diameter.



### Flexible ducts and fittings for ventilation, air conditioning and heating (Catalogue no. 14)

Flexible and semi-flexible air ducts made of polymeric materials, aluminium, galvanized or stainless steel, metal fittings for ventilation, air conditioning, heating, gas handling and abrasive particles aspiration.



**Air handling units  
AIRVENTS  
(Catalogue no. 3)**

Energy saving air handling units with air capacity up to 40 000 m<sup>3</sup>/h, for use in large residential, industrial and commercial objects.

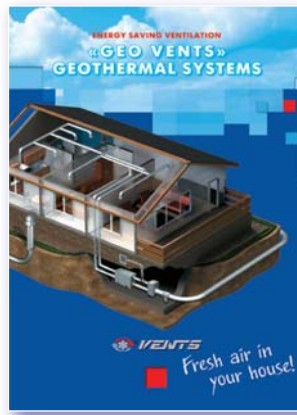

**Energy saving ventilation  
Geothermal systems  
GEO VENTS  
(Catalogue no. 4)**

Energy saving system GEO VENTS with use of the earth's surface layers heat. High ventilation system energy efficiency and low operating costs.



**Domestic fans  
(Catalogue no. 7)**

Domestic fans with air capacity up to 365 m<sup>3</sup>/h with extra functions: timer, humidity sensor, motion sensor, etc. Applied for premises up to 30 m<sup>2</sup>.

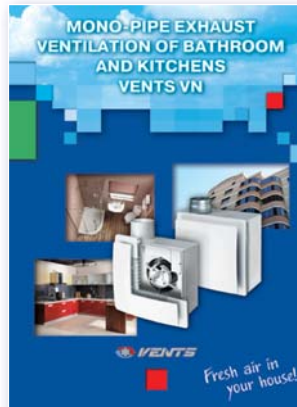

**VENTS VN  
Mono-pipe exhaust ventilation  
(Catalogue no. 8)**

Exhaust ventilation in houses with mono-pipe ventilation system based on VENTS VN fans.



**Plastic grilles for ventilation and air conditioning  
(Catalogue no. 11)**

PROFIPLAST extruded plastic grilles for ventilation and air conditioning.

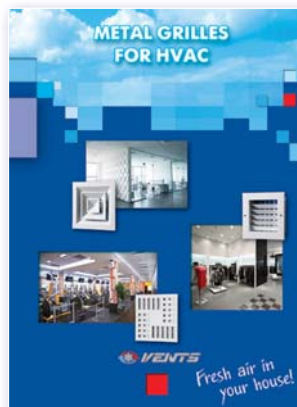

**Metal grilles for ventilation, air conditioning and heating  
(Catalogue no. 12)**

Metal grilles made of extruded metal profile for ventilation and air conditioning.

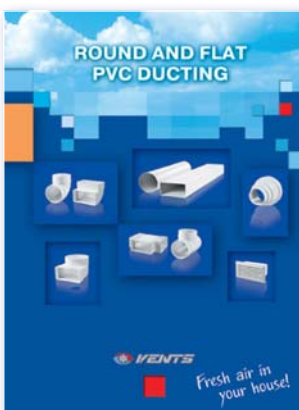

**Flat and round PVC air ducts  
(Catalogue no. 15)**

Flat and round PVC ducts PLASTIVENT for ventilation of residential, office and commercial premises and connection of exhaust ventilation equipment (kitchen extractors, hoods, exhaust boxes, etc). Wide product range of fittings.

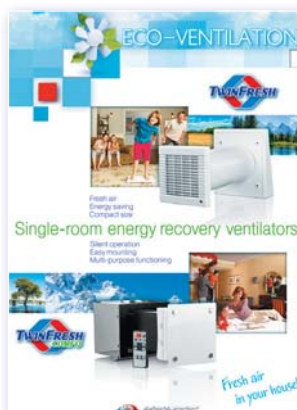

**Energy saving ventilation.  
Single room energy recovery ventilators.  
(Catalogue no. 16)**

Single room reverse ventilators with energy regeneration for efficient ventilation and lowest investments in ready-built and brand new premises.

## CONTENT

About VENTS.....	8
Ventilation in our life.....	10
Domestic fans options.....	14
Designation key.....	15
Domestic fans.....	16
Intellectual fans.....	18
Low-noise and energy-saving axial fans.....	22
Axial inline fans.....	30
Axial wall- and ceiling-mounted fans.....	36
Axial decorative fans.....	66
Axial window fans.....	94
Centrifugal fans.....	104
Fan mounting examples.....	110
Fan wiring diagrams.....	113
Accessories.....	114
Alphabetic index.....	127

## INTELLECTUAL FANS



Intellectual fan  
**iFan**  
**iFan Move**

page  
**20**

## LOW-NOISE AND ENERGY-SAVING AXIAL FANS



Low-noise and energy-saving  
axial fans  
**VENTS Quiet**

page  
**24**



Low-noise and energy-saving  
axial fans  
**VENTS Silenta-M**

page  
**26**



Low-noise and energy-saving  
axial fans  
**VENTS Silenta-S**

page  
**28**

## AXIAL INLINE FANS



Axial inline fans  
**VENTS VKO**  
**VENTS VKOk**

page  
**32**



Axial inline fans  
**VENTS VKO1**  
**VENTS VKO1k**

page  
**34**

## AXIAL WALL- AND CEILING-MOUNTED FANS



Axial fans  
**VENTS M**

page  
**38**



Axial fans  
**VENTS M3**

page  
**40**



Axial fans  
**VENTS M1**

page  
**42**



Axial fans  
**VENTS MA**

page  
**44**

Axial reverse fans  
**VENTS MA reverse**

page  
**46**



Axial fans  
**VENTS X1**

page  
**48**



Axial fans  
**VENTS F**

page  
**50**



Axial fans  
**VENTS F1**

page  
**52**



Axial fans  
**VENTS K**

page  
**54**



Axial fans  
**VENTS K1**

page  
**56**



Axial fans  
**VENTS PF**

page  
**58**



Axial fans  
**VENTS PF1**

page  
**60**



Axial fans  
**VENTS S**

page  
**62**



Axial fans  
**VENTS D**

page  
**64**

## AXIAL DECORATIVE FANS



Axial decorative fans  
**VENTS LD**

page  
**68**



Axial decorative fans  
**VENTS LD Auto**

page  
**70**



Axial decorative fans  
**VENTS LD light**

page  
**72**



Axial decorative fans  
**VENTS LD Fresh time**

page  
**74**



Axial decorative fans  
**VENTS Modern**

page  
**76**



Axial decorative fans  
**VENTS Modern Auto**

page  
**78**



Axial decorative fans  
**VENTS Domino**

page  
**80**



Axial decorative fans  
**VENTS Z**  
**VENTS Z star**

page  
**82**



Axial decorative fans  
**VENTS Vitro**  
**VENTS Vitro star**

page  
**86**



Axial decorative fans  
**VENTS X**  
**VENTS X star**

page  
**90**

## AXIAL WINDOW FANS



Axial window fans  
**VENTS MAO1**  
**VENTS MAO2**

page  
**96**



Axial window reverse fans  
**VENTS MAO1 reverse**

page  
**98**



Axial window fans  
**VENTS M10K2**

page  
**100**



Axial window fans  
**VENTS VV**

page  
**102**

Axial window reverse fans  
**VENTS VVR**

## CENTRIFUGAL FANS



Centrifugal single speed fans  
**VENTS CF**

page  
**106**



Centrifugal three speed fans  
**VENTS CF3**

page  
**108**

## ELECTRICAL ACCESSORIES



Fan control unit  
**BU-1-60**

---

page  
**116**



Thyristor controllers  
**RS**

---

page  
**117**



Autotransformer controller  
**RSA**

---

page  
**119**



Speed switches  
**P2, P3, P5**

---

page  
**120**



Temperature regulators  
**RTS, RTSD, RT**

---

page  
**122**



Transformers  
**TRF**

---

page  
**124**



Back valve  
**KO series**

---

page  
**126**





# WELCOME TO THE VENTS WORLD!



VENTS company was founded in the nineties of the XXth century.

Dynamic development of the enterprise and ongoing study of the consumer demand enabled rapid international leadership of the company in the ventilation industry.

VENTS is a powerful research and development enterprise with 2500 professionals working as a single team to ensure a full production cycle from idea to end product. The production base of the company is located at more than 60 000 m<sup>2</sup> area. It includes 16 workshops equipped under the latest international standards and each of them is comparable to a separate plant.

Modern equipment, active implementation of advanced technologies and highly automated production are the characteristic features of VENTS company.

The company undergoes rapid dynamic development; fundamental researches and effective designs in climatic equipment industry are in the focus of the company's business strategy.

The joint cooperation of the corporate design department, test laboratories and production workshops let us introduce high quality products to the market.

Special attention is paid to the manufacturing of the goods during all manufacturing stages including monitoring of the technological conditions. Technical characteristics of supplied raw materials are thoroughly checked. Quality control system which meets international standard requirements ISO 9001:2000 was implemented at the enterprise.

Environmental protection is one of the basic components of the corporate development. The technological process at the enterprise is arranged in such a way as to exclude any negative impact to the environment. To solve the global energy saving problem we develop a special climatic equipment that provides comfortable conditions for people and reduces the energy demand significantly.

Perfect quality, competitive prices, high production potential, technical capabilities and the wide product range stimulate long-term partnership and product promotion all over the world.

The VENTS ventilation products are exported to more than 90 countries and are sold through the distribution network of 120 companies worldwide. Share of the VENTS products globally is above 10%.

VENTS is a member of high-rank international organizations, the leading HVAC experts.

Since 2008 VENTS has been a fully-featured member of HARDI Association (Heating, Air-conditioning and Refrigeration Distributors International, USA).

Since 2010 VENTS has been a participant of AMCA Association (the Air Movement and Control Association (AMCA) International, Inc.). In 2011 VENTS successfully passed tests for compliance with AMCA standards and the VENTS products were certified for the USA market.

In 2011 VENTS joined HVI (Home Ventilation Institute, USA) Association.





Metal processing workshop



Spiral air ducts workshop



Flexible air ducts workshop



Aluminium grilles and diffusers workshop



Powder coating workshop



Wet coating workshop



Extrusion workshop



Injection moulding workshop



Residential fans workshop



Ventilation grilles workshop



Electric motors workshop



Industrial fans workshop



Air handling units workshop



AirVents air handling unit workshop



Electrical accessories workshop



Extruded grilles workshop

Powerful production facilities, high automation level, active implementation of innovative technologies in the production process made VENTS a worldwide ventilation leader.

We manufacture our products with respect to unique geographical, climatic, technical features of each country and do our best to fulfill the client's wishes anywhere anytime.



**Get benefit from cooperation with VENTSTM and enjoy the maximum range of products of the top quality from one manufacturer.**

# VENTILATION IN OUR LIFE



## ▶ What is ventilation?

Ventilation is a complex of actions and facilities used for air exchange arrangement to provide the specified air condition in the premises and in working places.

Ventilation systems maintain admissible meteorological parameters in various premises. Ventilation system should create the internal atmosphere that meets the specified hygienic standards and technological requirements.

## ▶ What is ventilation required for?

We are surrounded with air and breathe in and out 20 000 litres of air every day. How much healthy is the air we breathe in?

There is a range of aspects to determine air quality.

- ▶ **Oxygen and Carbon Dioxide Concentration in the Air.** Oxygen decrease and carbon dioxide cause stuffiness in the premises.
- ▶ **Harmful Substances and Dust in the Air.** High content of dust, tobacco smoke and other substances in the air are harmful for the human organism and can cause various lung and skin diseases.
- ▶ **Odours.** Bad smell causes discomfort or irritates nervous system.
- ▶ **Air Humidity.** High or low humidity causes discomfort and even may result in acute disease attacks. Air humidity is important also for the internal atmosphere. So, decreased humidity in winter can cause shrinkage and cracks of wooden doors, window frames, furniture and high humidity in swimming pools and bathrooms and other humid premises can cause excessive humidity absorption and swelling.
- ▶ **Air temperature.** A person feels comfortable in a premise with the temperature 21-23°C. Temperature variation causes the change of «comfort» well-being more or less that influences a person's physical and mental activity.
- ▶ **Air Motion.** Increased air speed in the premises causes the feeling of draft, and decreased speed causes air blanketing. Being inside we feel the impact of any of these factors.

## ▶ Ventilation system arrangement

Properly arranged ventilation system is the only solution in this situation. It provides filtered air supply in summer and filtered and warmed supply air in winter as well as extract stale air removal from the premises.

Any ventilation system must include synchronous fresh air supply and extract air exhaust thus ensuring the ideal air balance in the room. In case of poor or insufficient

air intake from outside the oxygen content decreases, humidity and dustiness level increase. If exhaust ventilation is not provided or it is not effective, polluted air, smells, humidity and harmful substances are not removed.

Well coordinated operation of supply and exhaust air vents is one more important factor for properly arrangement of ventilation system. In case of exhaust ventilation only (i.e. exhaust ventilation in the bathroom) air from outside flows through all possible gaps in windows, doors and walling. Such non-arranged air supply brings dust ingress, smells and drafts.

The door grilles installed in the bathrooms, wall or window vents, open windows or window leaves serve as natural sources of supply ventilation and are used to compensate air removal. However, forced mechanical ventilation with centralized air supply and distribution is a much better solution.

## ▶ Calculation of the required air exchange

### Engineering recommendations

Effective ventilation depends on fan or ventilation system selection with suitable air capacity that meets your requirements.

Some factors to be considered:

- Ventilated area volume
- Air exchange by the hour

Multiple the ventilated premise volume by air exchange per hour and get the required fan capacity.

### Air exchange calculation according to the ventilation rate in the room.

Ventilated air amount is calculated on an individual basis for each premise with respect to harmful substances content or is determined by test results. If the nature and number of harmful impurities (substances) cannot be identified or measured air exchange is calculated with the formula:

$$L = V_{\text{area}} * K_p \quad (\text{m}^3/\text{h}),$$

where:  $V_{\text{area}}$  – ventilated area volume [ $\text{m}^3/\text{h}$ ].  $K_p$  – minimum air exchange per hour, see air exchange table.

### How to calculate ventilated area volume?

Calculate the total volume of the premise in  $\text{m}^3$ . Use a simple formula:

$$\text{Length} \times \text{Width} \times \text{Height} = \text{Volume of the premises } \text{m}^3$$

$$A \times B \times H = V \quad (\text{m}^3)$$

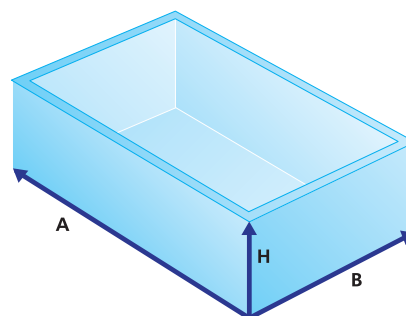

Example: premise with 5 m length, 3 m width and 2.8 m height. To determine the air volume required for ventilation of this premises, calculate the volume of the room:  $5 \times 3 \times 2,8 = 42 \text{ m}^3$ . After that determine the required fan capacity using the following tables of recommended ventilation rate.

**► Natural and mechanical ventilation**

Natural ventilation requires no electric equipment such as fans or motors and is originated by natural seasonal factors as external and internal air temperature drop, pressure level as a function of height, wind loading. But no matter of the season or weather natural ventilation cannot provide full-featured air exchange. Natural ventilation is enough to provide minimum air exchange for passive ventilation of periodically occupied premises but its capacity is not enough for well balanced air exchange.

Mechanical ventilation devices ensure active air exchange and can operate continuously or periodically depending on the ventilation need. Unlike natural ventilation, mechanical ventilation operates regardless of natural conditions and indoor and outdoor temperature difference. Fan and electric motors are the basic mechanical ventilation components that provide controllable air exchange. So mechanical ventilation is the best solution.

Natural ventilation	Mechanical ventilation
easy and value-priced, provided during construction stage	easy assembling and layout in case of correct equipment and materials selection and installation during construction or finishing works. In some cases installation after finishing works is possible
no electric mechanisms and no power supply connection	requires connection to power mains and consumes electric energy
no failure possibility	the modern fans reliability is quite high, however as all mechanical devices they can break down
weather-dependent efficiency: very low in summer	provide required ventilation no matter of season and weather conditions
limited ventilation rate regulation	higher air exchange rate is effected by switching the fan to higher speed
significant thermal losses in winter open windows for ventilation in summer	reducing heating costs in case of use of heat recovery technology
excessive air flow or backdraft in case of strong wind pressure	fans provide required air flow and backdraft dampers provide required air distribution
no air filtration, heating or cooling	filtration, heating or cooling intake air from outside before supplying it to the premise
drafts make feel uncomfortable	no draughts as ventilation does not require open windows

**Air exchange rate:**

Premise type	Air exchange rate	
Residential premises	Living room	3 m <sup>3</sup> /h per 1m <sup>2</sup> for residential premises
	Kitchen	6-8
	Bathroom	7-9
	Shower room	7-9
	WC	8-10
	Domestic laundry	7
	Dressing room	1,5
	Store room	1
	Garage	4-8
	Cellar	4-6

**► Ventilation shaft functionality check**

Make sure of available ventilation pressure in the shaft before mounting a fan inside. Ventilation shafts may be clogged by construction waste or closed because of incorrect construction alteration of flat(s) above. To check the ventilation pressure in the shaft cover it with a paper sheet. If the ventilation pressure is enough the paper sheet sticks to the shaft surface. Otherwise you have to contact your house manager to get the ventilation shaft duly operable.

**► Provide even ventilation for all the premise**

Air motion in the room depends not only of supply and exhaust ventilation accessories but on their location.

Fan operation generates low pressure area that attracts fresh air supply through any openings and slots. That is why location of supply and exhaust ventilation accessories is of great importance for ventilation system efficiency. In other words, air supply and air exhaust vents should be located in such a way as to ensure fresh air motion throughout all the room space. For large premises it is recommended to install several fans with low or medium capacity instead of one high-powered fan to observe the total air capacity.



## ▶ Fan types:

Fans are the mechanical devices that provide air motion along air ducts, direct air supply or air exhaust from the premise. Air motion is effected due to pressure drop between the fan intake and exhaust.

## ▶ High efficiency at low air resistance

**Axial fans** are the wheels with blades (so called impeller) enclosed in cylindrical casings and attached to the hub at required angle to plane of rotation.

As impeller blades rotate air is trapped between the blades and moved further axially. Air is hardly moved in radial plane of rotation. Normally the axial fan blades are fixed directly to the motor shaft.



**Application:** air exhaust and air supply through free openings or vents or in assembly with air ducts mounted up to 30 m horizontally with low air resistance in the system.

## ▶ Solutions for long air ducts

Turbine and scroll casing are the basic components of the **centrifugal fan**. The centrifugal fan impeller is a hollow cylinder with the blades inside that are fixed to the cylinder circumference with disk plates. The hub is located inside of these plates and is designed for mounting of the impeller on the shaft. As the impeller rotates air is trapped between its blades, gets pressurized and moves in radial direction from the center.

Under centrifugal force air is transported to the scroll casing and then to the exhaust pipe.

**Applications:** air exhaust and air supply in ventilation systems with extended air ductworks and high air resistance.



## ▶ Fan noise level characteristics

Noise parameters are shown in the tables that include the following characteristics:

- ▶ Noise level LWA, dB(A) with various frequency band groups, LWA inlet, LWA outlet and LWA surrounding.
- ▶ The total sound power level at 3 m distance.

The frequency band has eight wave groups. Each group has a definite medium frequency: 63 Hz, 125 Hz, 250 Hz, 500 Hz, 1000 Hz, 2 kHz, 4 kHz and 8 kHz.

Any noise is classified according to frequency bands and the sound energy has various frequency groups.

The sound produced by the operating fan is spread along the air duct, get partially attenuated inside the unit and penetrates through the grilles inside the premise.

Ventilation system design is based on acoustic calculation which is an integral part of any ventilation project for any construction object.

The calculation is aimed to define the octave-frequency band in various operating points and to determine the required sound attenuation level by comparing this spectrum with the permissible values according to hygienic norms and standards. After selection of the design and acoustic facilities to be used for noise level reducing the sound pressure levels are checked for consistence with expected values in the same operating points.

dB(A)	Characteristics	Sound source
0	no noise	
5	almost not audible	
10		low leaves rustling
15	hardly audible	medium leaves rustling
20		human whisper (1 m distance)
25	low noise	human whisper (1 m distance)
30		whisper, wall clock ticking
		standard sound level for residential premises from 23.00 till 07.00
35	audible enough	low speech
40		standard speech
		standard sound level for residential premises from 07.00 till 23.00
45	definitely audible	conventional conversation
50		conversation, typing
55		Standard sound level for class A offices (EN)
60	noisy	office standard sound level
65		loud conversation (> 1m)
70		several conversations (< 1m)
75		loud conversation (< 1 m)
80	very noisy	shouting, operating motorcycle with a silencer
85		loud shouting, operating motorcycle with a silencer
90		Loud shouts, moving railway vehicle (7 m)
95		moving subway train (7 m)
		Orchestra, top noise level of the moving subway train, thunder
100	extremely noisy	Maximum permissible sound pressure for headphones of a personal stereo (EN)
105		inside the airplane (before 1980s)
110		helicopter
115	nearly unbearable	sandblaster (1 m)
120		pneumatic hammer (1 m)
130	pain threshold	airplane at start

## ▶ What is IP?

While selecting the equipment and its location it is extremely important to ensure compliance of the protection rating to the operating conditions. Any electrical device must meet two protection requirements:

- ▶ safety for the user and operating personnel
- ▶ protection of the electrical components located in the device against environmental impact.

IP rating refers to dust and moisture protection of the equipment and its electrical safety. Ingress protection rating marked as IP followed by two digits is stated in the technical documentation and on the equipment casing. F.e. IP20 or IP65. The first digit means protection rating against contact to the electrical parts and contact to foreign objects. The first digit designations and characteristics are listed in the table 1.

THE SECOND DIGIT MEANS WATER INGRESS PROTECTION RATING AND ITS DESIGNATIONS AND CHARACTERISTICS ARE LISTED IN THE TABLE 2.







**Table 1**

First digit	Protection characteristics	Description
x	No special protection	Open design, no special protection against dust ingress and contact to electrical parts.
1	Protection against large objects	Protected against large solid objects up to 50 mm, e.g. accidental contact with hands.
2	Protection against medium-sized objects	Protected against solid objects up to 12 mm, e.g. fingers contact to electrical parts.
3	Protection against small objects	Protected against penetration of solid objects over 2.5 mm (tools and wires). Protection against accidental contact to electrical parts with tools or fingers.
4	Protection against sand penetration	Protected against solid objects over 1 mm (small tools and wires). Protection against accidental contact to electrical parts with tools or fingers.
5	Protection against dust accumulation	Very limited dust ingress inside the casing that does not disturb the rated equipment operation. Total protection against contact to electrical parts.
6	Total dust ingress protection	Total protection against dust penetration.

**Table 2**

Second digit	Protection characteristics	Description
x	No protection	Open design, no water protection
1	Protection against vertically falling drops of water.	Vertically falling drops of water e.g. condensation cause no harmful effect for the equipment.
2	Protection against water drops falling at angle	Water drops falling at 15° or less cause no harmful effect for the equipment.
3	Protection against water sprays	Water sprays falling at 60° or less cause no harmful effect for the equipment.
4	Protection against water sprays from all directions	Water sprays from all directions cause no harmful effect for the equipment.
5	Protection against water jets	Directed water jets cause no harmful effect for the equipment in the casing.
6	Protection against flooding of water	Water flooding causes no harmful effect for the equipment in the casing.
7	Protection against immersion in water	Immersion of the casing in water causes no harmful effect for the equipment inside the casing.
8	Protection against immersion in water under pressure	Immersion of the equipment in water to some depth causes no harmful effect (protection against pressurized water, the pressure value is stated separately).

## Certification

	CE mark means that the equipment is produced in compliance with the quality and safety standards provided by EU regulations for the given product type (marked by manufacturer).		Mark of conformity to the Ukrainian Quality Standards and electrical safety issued by UkrTEST.
	Mark of conformity to the European Quality Standards and Electrical Safety issued by Association for Technical Inspection (Technischer Überwachungsverein, Germany).		Mark of conformity of the goods subject to obligatory certification in DSTR system as well as technical norms and standards acting in Russian Federation. Confirmed by the RosTEST certificates (Moscow).
	Mark of conformity to the Polish Quality Standards and electrical safety issued by PCBC (Polish center for testing and certification).		Insulation class: double insulation.
	Mark of conformity to the Slovak Quality Standards and electrical safety issued by EVPU (Slovakia).	<b>IP 34</b>	Equipment protection rating (refer to tables 1, 2).



## **Pull cord switch**

Fan is switched on and off by a pull cord. The pull length is adjustable.



## **Timer**

On power-off the fan continues operating within the time period set by the timer setting from 2 to 30 minutes.



## **Humidity sensor**

Fan is equipped with an electronic processor with permanent humidity level monitoring function that prevents condensate generation. The fan switches automatically on as the relative humidity in the premise reaches the preset threshold value adjustable from 60 to 90% and continues operating within 2 to 30 minutes according to the timer setting.



## **Motion sensor**

Fan switches automatically on in case of motion detection in the premises and continues operating within the time period from 2 to 30 minutes according to the timer setting. The motion sensitivity area from 1 to 4 m and the detection angle up to 100°.



## **Ball bearings motor**

Fan motors are equipped with ball bearings that ensure long service life rated for 40.000 hrs and reliable operation in case of ceiling mounting.



## **Turbo**

Fan is equipped with a high-powered electric motor for higher air capacity.



## **Press**

Models are equipped with a 5-blade silent operation impeller with improved aerodynamics for higher fan pressure. Such impeller design allows attaining previously unachievable air capacity characteristics for axial fans.



## **12 V**

Fan is equipped with a low-voltage (12 V) electric motor for safe operation in humid areas and spaces with high water ingress probability (bathrooms, saunas etc.).



## **Backdraft damper**

Fan is equipped with a backdraft damper for air back flow preventing. The backdraft damper is supplied as a standard with all modifications of M, M1, D, S, M3, X, X1, and LD fans. The damper is also available as a separate equipment for KO 100, KO 125, and KO 150 models.

VENTS	Flange diameter [mm]	Series	Built-in options	Extra Option	Motor options
	100 125 150 180 230		V - Pull cord switch T - Timer TH - Humidity Sensor TP - Motion Sensor	Backdraft damper	Ball bearings motor (L) Turbo Press 12 V

■ Designation key example

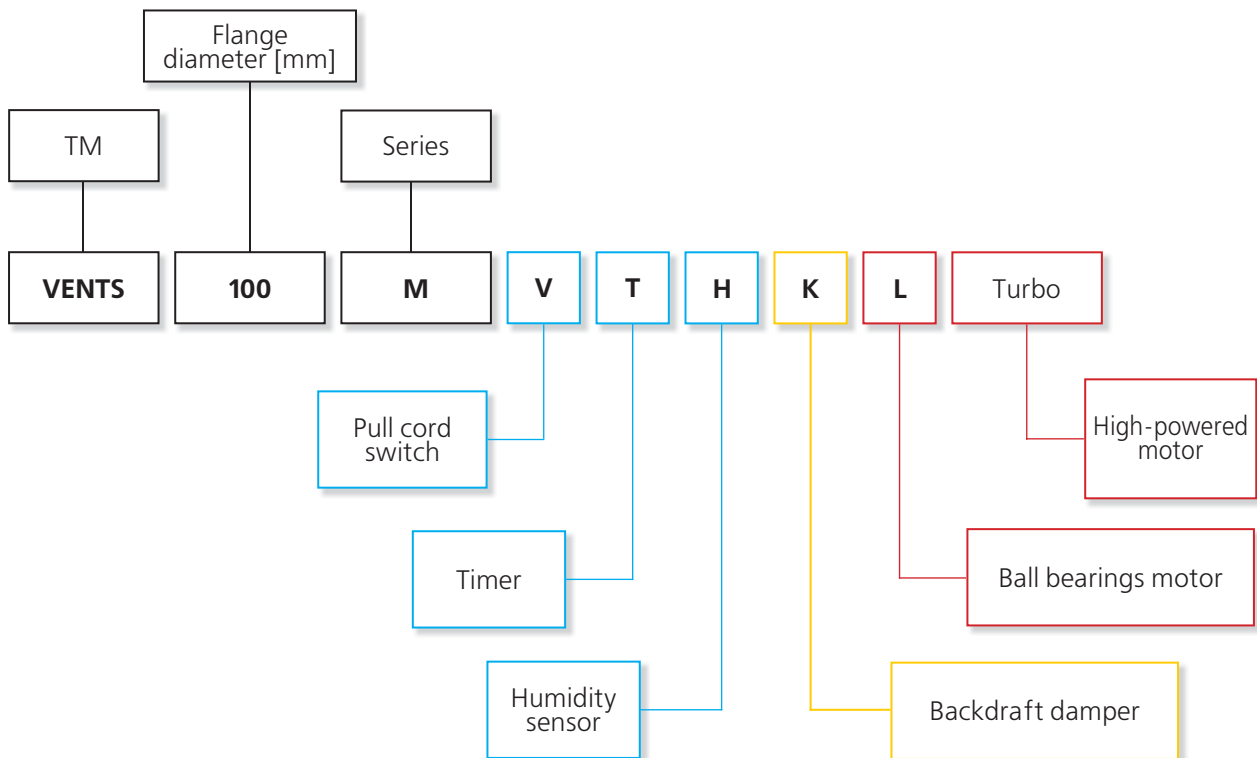



# DOMESTIC FANS

FOR AREAS UP TO 30 m<sup>2</sup>

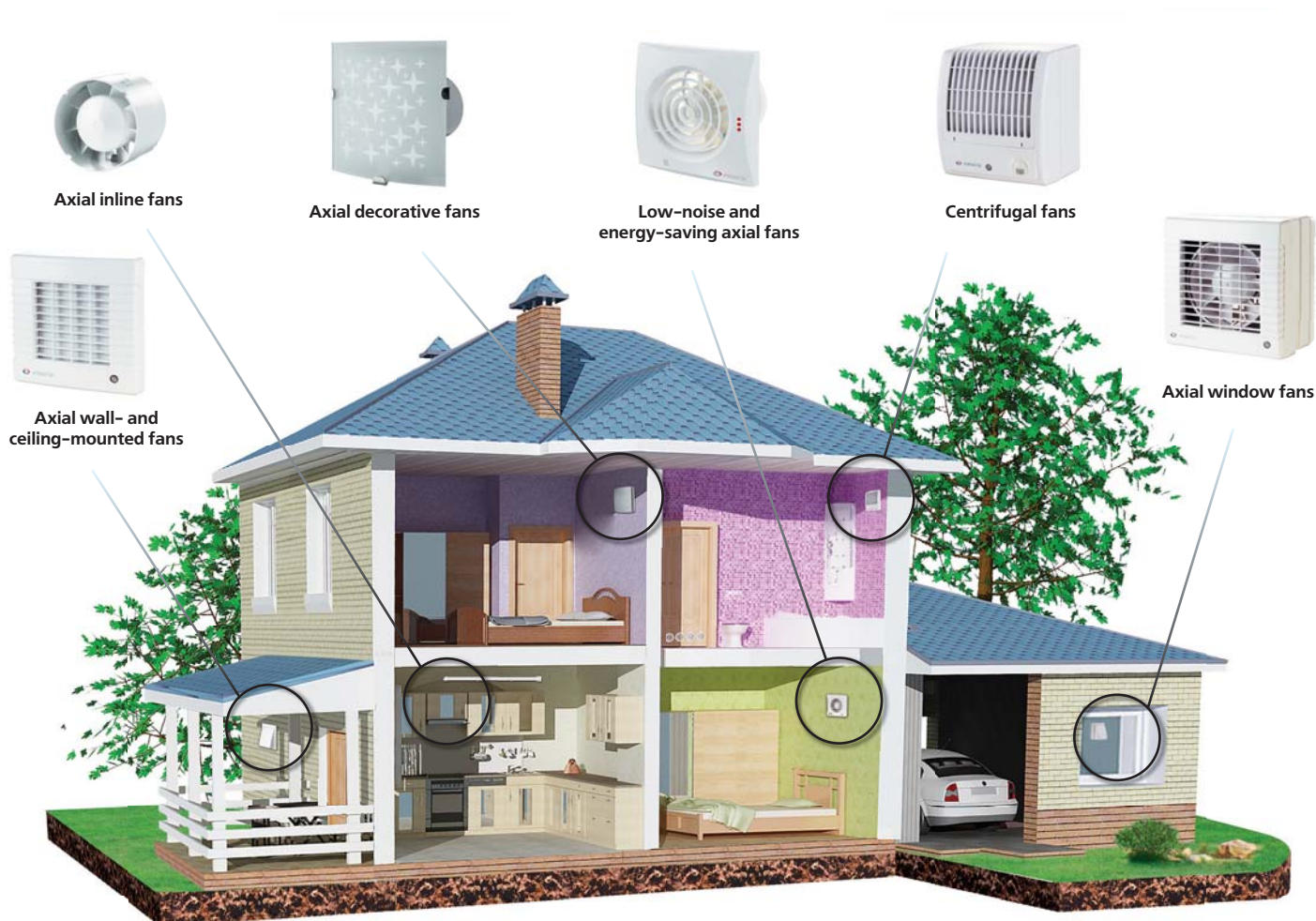

VENTS offers a wide range of domestic fans that combine outstanding performance and reliability with low power consumption and noise levels. These units are the perfect solution for ventilating bathrooms, kitchens, living quarters and other premises of up to 30 m<sup>2</sup>.

VENTS fans are available in manifold modifications with various air capacity, design and functioning.



**Intellectual fans**

page  
18



**Low-noise and energy-saving axial fans**

page  
22



**Axial inline fans**

page  
30



**Axial wall- and ceiling-mounted fans**

page  
36



**Axial decorative fans**

page  
66



**Axial window fans**

page  
94



**Centrifugal fans**

page  
104



# INTELLECTUAL FANS

***i*fan**  
*intelligent fan*

**Intellectual ventilation era!**





**Intellectual fans  
VENTS iFan Series**

Air capacity up to 133 m<sup>3</sup>/h

page  
20



**Intellectual fans  
VENTS iFan Move Series**

Air capacity up to 133 m<sup>3</sup>/h

page  
20

## iFan iFan Move Series



21 dBA

3,8 W

133 m³/h

Intellectual axial fans for exhaust ventilation with air capacity up to 133 m³/h

### Applications

- Innovative exhaust fan with stylish design for new comfort level in shower rooms, bathrooms, kitchens and other residential premises.
- Intellectual integrated control functions let adjust personal settings for the most balanced microclimate.

### Design

- Unique motor design and aerodynamic impeller profile ensure the minimum noise level - only 21 dBA whereas the air capacity remains high.



- Front panel 3D design and rich colour palette of replaceable decorative panels give zest to the most refined interior.

- Due to replaceable spigots the fan is suitable for mounting with Ø 100 or Ø 125 mm air ducts.



- The motor-impeller block is easy to remove without special tools which grants easy servicing.



- The fan has a ultra-thin casing with its thickness only 29 mm without a spigot.
- The fan is equipped with an integrated on/off power slide switch for quick disconnection from power mains.

### Motor

- Reliable motor on ball bearings with minimum energy demand up to 3.8 W.
- The bearings are maintenance-free and are filled with grease for the motor service life.
- The fan is powered through an integrated pulse power supply unit with a wide power supply range from 100 to 240 V and 50 to 60 Hz. The fan is suitable for application in various countries and has stable operation in versatile power mains.
- The motor is installed on a rubber anti-vibration connector for vibration absorbing and silent fan operation.
- The motor is equipped with overheating protection.

### Modifications and Options



Basic model with intellectual humidity control.



Model with intellectual humidity control and extra motion sensor control.

### Intellectual functions

- Multi-functional control panel for control of intellectual functions.



### HUMIDITY MODE / Humidity control adjustments

- The fan is equipped with an intellectual humidity sensor with three operation modes:

**SLEEP** – the fan is ready to accept a signal from the humidity sensor or external switch.

**SILENT** – optimum humidity extraction mode that provides sufficient air capacity (up to 83 m³/h) combined with silent operation.

**MAX** – excessive humidity extraction mode with highest speed and maximum air capacity (up to 133 m³/h).



### TIMER / Control of time / humidity extraction / switch delay time / turn-off delay time

- The fan is equipped with three timers:

**Humidity timer** – setting of the fan operation for total humidity extraction after its stabilization (30, 45, 60 min).

**Turn-off timer** – the fan continues operation for 5, 15 or 30 minutes after activation of the motion sensor or the external switch and then reverts to the previous operation mode.

**Switch delay timer** - adjust the switch delay timer to avoid the fan unnecessary switching if you use your bathroom shortly and frequently. After humidity increases or after signal from the external switch/motion sensor, the fan switches to higher speed not immediately, but after the timer countdown (0, 2 and 5 minutes).



### SPEED / Fan speed adjustments

- The fan has smooth ten step speed control:
  - for **SILENT** mode: from 40/33 to 83/72 m³/h (Ø 125/100 mm);
  - for **MAX** mode: from 83/72 to 133/106 m³/h (Ø 125/100 mm);



### 24 HOURS / Permanent ventilation

- Permanent low-speed operation mode ensures continuous minimum air exchange in the room with air capacity 40/33 m³/h (Ø 125/100 mm). After humidity change the fan is switched to MAX mode (by default) or SILENT mode. The fan is switched to SILENT mode after signal from the motion sensor or external switch.



### Automatic interval ventilation

- Integrated function of automatic ventilation switching. Once in 15 hours the fan is switched on for 2 hours to ventilate the premise with air capacity 83/72 m³/h (Ø 125/100 mm).



### MOVE / Motion sensor (for the model iFan Move)

- The fan is switched to SILENT mode automatically in case of a signal from the motion sensor with the reach distance 1-4 m and viewing angle 100°.

### Decorative front panel colours\*



melange



silver



ruby star



topaz violet



graphite



black sapphire

\* The decorative panels are available separately.

### Aerodynamic characteristics

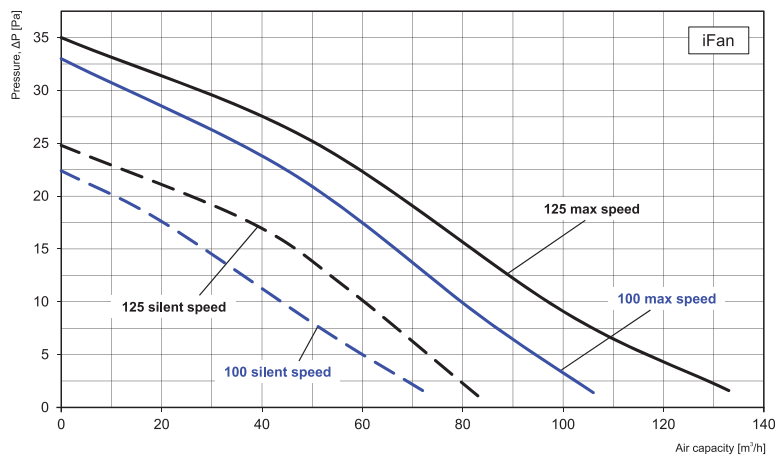

### Overall dimensions

Model	Dimensions, mm				
	Ø D	B	H	L	L1
iFan	100/125	152	206	57	29
iFan Move					

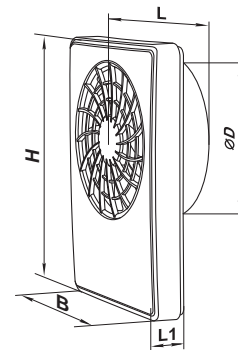

### Technical data

Model	Spigot diameter [mm]	Mode	Max. air capacity [m³/h]	Sound Pressure Level at 3 m [dB(A)]	Air capacity, factory settings [m³/h]	Regulation range [m³/h]
iFan iFan Move	100	24 HOURS	33	17	33	-
		SILENT	72	22	72	33...72
		MAX	106	31	82	72...106
	125	24 HOURS	40	17	40	-
		SILENT	83	21	83	40...83
		MAX	133	32	97	83...133

### Certificates

The fans meet the applicable safety and electromagnetic compatibility standards.

# LOW-NOISE AND ENERGY-SAVING AXIAL FANS

## ▶ VENTS Quiet Series



Innovative exhaust fans with stylish design for new comfort level. Maximum air capacity 97 m<sup>3</sup>/h is combined with new comfort level provides the ideal microclimate. Mounting with Ø 100 mm air ducts.

## ▶ VENTS Silenta-M Series



Axial low-noise fans for exhaust ventilation with air capacity up to 242 m<sup>3</sup>/h. Mounting with Ø 100, 125 and 150 mm air ducts.

## ▶ VENTS Silenta-S Series



Axial low-noise fans for exhaust ventilation with air capacity up to 240 m<sup>3</sup>/h. Mounting with Ø 100, 125 and 150 mm air ducts.



**Axial fans**  
**VENTS Quiet Series**

Air capacity - up to 97 m<sup>3</sup>/h

page  
24



**Axial fans**  
**VENTS Silenta-M Series**

Air capacity up to 242 m<sup>3</sup>/h

page  
26



**Axial fans**  
**VENTS Silenta-S Series**

Air capacity up to 240 m<sup>3</sup>/h

page  
28



## VENTS Quiet Series



Intellectual axial low-noise and energy-saving fan for exhaust ventilation with air capacity up to 97 m<sup>3</sup>/h

### Applications

- Innovative exhaust fan with stylish design for new comfort level in shower rooms, bathrooms, kitchens and other residential premises.
- Maximum air capacity combined with low noise level provide the ideal microclimate.
- Mounting into ventilation shafts or connection to Ø 100 mm.

### Design

- Casing and impeller made of high-quality and durable UV-resistant plastic.
- The stylish design matches well with any interior.
- Specially designed aerodynamic profile provides high air capacity and low noise.
- The compact design enables wall and ceiling mounting.
- The shortened spigot (81 mm) for mounting into a ventilation shaft or connection to Ø 100 mm air duct.
- The fan is equipped with a specially designed back valve to prevent back flow and heat losses during the fan standby.

- The fan exhaust spigot incorporates specially designed air rectifiers to reduce air turbulence, increase air pressure and lower noise level.
- High ingress protection rating IP 45 ensures makes the fan the ideal solution for ventilation of a bathroom. The electronic components are protected with tight covers.

### Motor

- Low energy demand 7.5 W due to new high-efficient motor.
- Maintenance-free bearings contain enough grease for 40 000 hrs non-stop operation.
- Motor on special anti-vibration dampers for vibration absorbing and silent operation.
- Motor equipped with overheating protection.

### Modifications and Options



**Quiet** - basic model with a back valve.



**Quiet T** - off-delay timer modification with operating time from 2 to 30 min.



**Quiet TH** - off-delay timer modification with the operating time from 2 to 30 min and humidity sensor with threshold from 60 to 90%.



**Quiet V** - pull-cord switch modification.



**Quiet VT** - modification with pull-cord switch and off-delay timer with operating time from 2 to 30 min.



**Quiet VTH** - modification with pull-cord switch, off-delay timer with operating time from 2 to 30 min and humidity sensor with threshold from 60 to 90%.



**Quiet TP** - modification with off-delay timer with operating time from 2 to 30 min and motion sensor; reach distance up to 4 m, viewing angle up to 100°.

### Control

#### Manual control:

- Manual control with a room light switch. The switch is not included into delivery set.
- The fan is controlled by the built-in pull cord switch **V**. Not applied in case of ceiling mounting.
- Speed control is possible through a thyristor speed controller (see Electrical Accessories). Several fans may connected to the same controller.

#### Automatic control:

- By the electronic control unit **BU-1-60** (see Electrical Accessories). The control unit is supplied separately.
- By the timer **T** (the built-in run-out timer enables the fan operation within 2 to 30 minutes after the fan switching off).
- By the humidity sensor and timer **TH** (if the humidity level in the room exceeds the sensor threshold within 60-90% the fan switches automatically on and operates until the humidity level drops to the standard level, after that the fan continues operating within the set time period and shuts down).
- By the motion sensor and timer **TP** (if motion is detected in the reach area, the fan is switched automatically and operates within the set time period from 2 to 30 min). Reach distance up to 4 m, the max. viewing angle 100°.

### Mounting features

- Installation directly inside a ventilation shaft.
- Flexible air ducts may be used in case of remote location of the ventilation shaft. Connection of the air duct to the exhaust flange with a clamp.
- Wall mounting with screws.
- Suitable for ceiling mounting.

### Aerodynamic characteristics

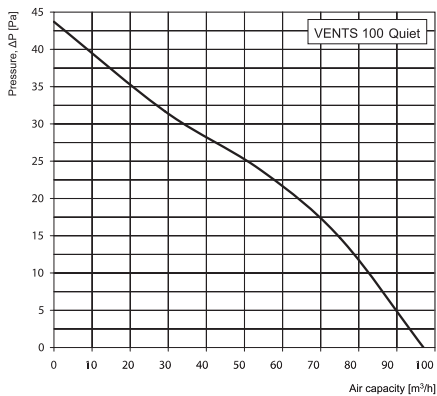

### Technical data

Model	Voltage [V] at 50 Hz	Power Consumption [W]	Current [A]	Maximum air capacity [m³/h]	Sound Pressure Level at 3 m [dB(A)]	Weight [kg]
VENTS 100 Quiet	230	7,5	0,049	97	25	0,55

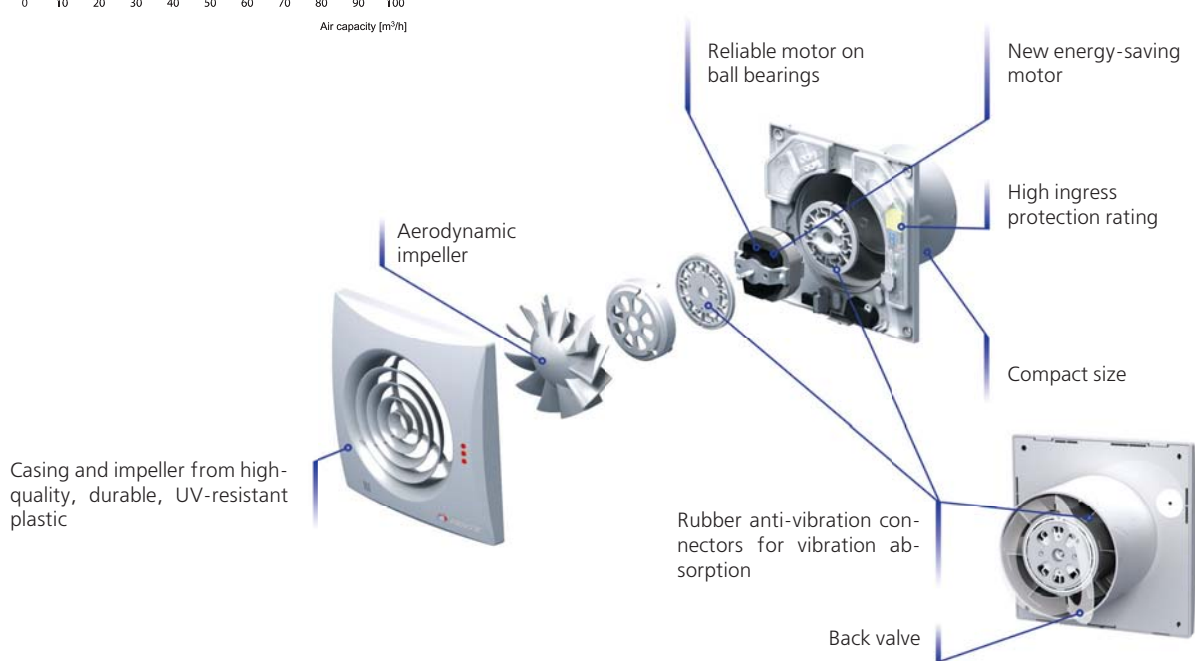

### Mounting example



### Overall dimensions

Model	Dimensions, mm				
	Ø D	B	H	L	L1
VENTS 100 Quiet	99	158	136	107	26

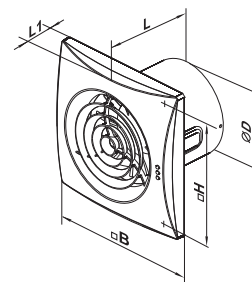

### Certificates

The fans meet the applicable safety and electromagnetic compatibility standards.

## VENTS Silenta-M Series



Low-noise and low-watt axial fans for exhaust ventilation with air capacity up to 242 m<sup>3</sup>/h

### Applications

- Continuous or periodic exhaust ventilation of bathroom, showers, kitchens and other utility spaces.
- Ventilation of premises with high noise level limitations.
- Ventilation shaft mounting or duct connection.
- Compatible with Ø 100, 125 and 150 mm air ducts.

### Design

- Modern design and aesthetic look.
- The casing and the impeller are made of high-quality durable ABS plastic, UV resistant.
- The intellectual impeller design makes the fan efficiency high and the service life long.
- The fan and motor are specially designed for silent operation.
- Protection rating IP 34.

### Motor

- Reliable motor with the minimum power consumption 5.5 W (for 100 mm diameter).
- Designed for continuous operation and requires no maintenance.
- Equipped with overheating protection.

### Modifications and Options



**Silenta-M K** – fan is equipped with a backdraft damper for back flow preventing.



**Silenta-M L** – the motor is equipped with ball bearings for long service life (appr. 40 thousand hours) and fan mounting at any angle. The bearings are maintenance-free and contain enough grease for the entire operating period.



**Silenta-MT** – equipped with a regulated timer with the operating time from 2 to 30 minutes.



**Silenta-MTH** – equipped with a timer with the operating time from 2 to 30 minutes and a humidity sensor with the threshold value from 60 to 90%.



**Silenta-MV** – equipped with a pull cord switch.



**Silenta-MVT** – equipped with a pull cord switch and a regulated timer with the operating time adjustable from 2 to 30 minutes.



**Silenta-MVTH** – equipped with a pull cord switch, regulated timer with the operating time adjustable from 2 to 30 minutes and a humidity sensor with the operating threshold range from 60% to 90%.



**Silenta-MTP** – equipped with a regulated timer and a motion sensor with the sensitivity area from 1 to 4 m and the detection angle up to 100°.

### Control

#### Manual:

- The fan is controlled by a room light switch. It is not included in the delivery package.
- The fan is controlled by the built-in pull cord switch **V**. Not applied in case of ceiling mounting.

- Speed control is possible through a thyristor speed controller (see Electrical Accessories). Several fans may be connected to the same regulator unit.

#### Automatic:

- By the electronic control unit **BU-1-60** (see Electrical Accessories). The control unit is supplied separately.

- By the timer **T** (the built-in run-out timer enables the fan operation within 2 to 30 minutes after the fan switching off).

- By the humidity sensor and timer **TH** (if the humidity level in the room exceeds the sensor threshold adjustable value within 60-90% the fan switches automatically on and operates until the humidity level drops to the standard level, after that the fan continues operating within the time period according to the timer setting, then shuts down).

- By the motion sensor and the timer **TP** (in case of motion detection the fan switches automatically on and operates within the set time period from 2 to 30 minutes. The motion sensitivity area is up to 4 meters and the maximum detection angle is 100°).

### Mounting features

- The fan is mounted directly into the ventilation shaft.
- Flexible duct application is recommended in case of remote location of the ventilation shaft. The air duct is connected to the fan exhaust flange through a clamp.
- Fixed to wall by self-tapping screws.
- Suitable for ceiling mounting.

### Accessories



### Aerodynamic characteristics

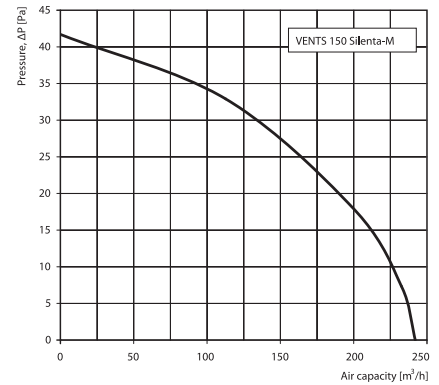
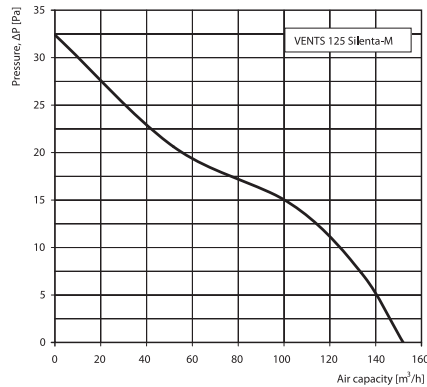
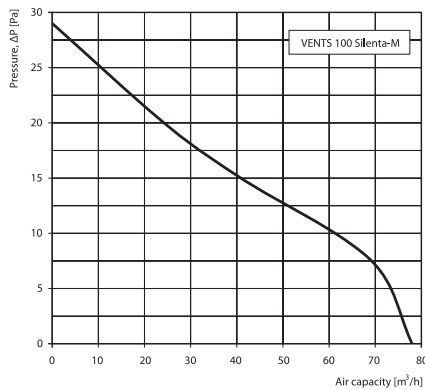

### Technical data

Model	Voltage [V] at 50 Hz	Power Consumption [W]	Current [A]	Maximum air capacity [m³/h]	Sound Pressure Level at 3 m [dB(A)]	Weight [kg]
VENTS 100 Silenta-M	230	5,5	0,035	78	26	0,48
VENTS 125 Silenta-M	230	9,1	0,059	152	31	0,63
VENTS 150 Silenta-M	230	20	0,14	242	33	0,82

### Overall dimensions

Model	Dimensions [mm]				
	Ø D	B	H	L	L1
VENTS 100 Silenta-M	100	159	135	89	23
VENTS 125 Silenta-M	125	180	150	94	25
VENTS 150 Silenta-M	150	206	182	106	26

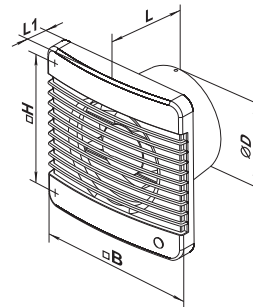

### Mounting example



### Certificates



The fans meet the applicable safety and electromagnetic compatibility standards.

## VENTS Silenta-S Series

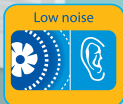

Low noise and low watt axial fans for exhaust ventilation with the capacity up to 240 m<sup>3</sup>/h

### Applications

- Continuous or periodic exhaust ventilation of bathroom, showers, kitchens and other utility spaces.
- Ventilation of premises with high noise level limitations.
- Ventilation shaft mounting or duct connection.
- Compatible with Ø 100, 125 and 150 mm air ducts.

### Design

- Modern design and aesthetic look.
- The casing and the impeller are made of high-quality durable ABS plastic, UV resistant.
- The intellectual impeller design makes the fan efficiency high and the service life long.
- The fan and motor are specially designed for silent operation.
- Insect screen.
- Protection rating IP 34.

### Motor

- Reliable motor with the minimum power consumption 5.5 W (for 100 mm diameter).
- Designed for continuous operation and requires no maintenance.
- Equipped with overheating protection.

### Modifications and Options



**Silenta-S K** – fan is equipped with a backdraft damper for back flow preventing.



**Silenta-S L** – The motor is equipped with ball bearings for long service life (appr. 40 thousand hours) and fan mounting at any angle. The bearings are maintenance-free and contain enough grease for the entire operating period.



**Silenta-ST** – equipped with a regulated timer with the operating time from 2 to 30 minutes.



**Silenta-STH** – equipped with a timer with the operating time from 2 to 30 minutes and a humidity sensor with the threshold value from 60 to 90%.



**Silenta-SV** – equipped with a pull cord switch.



**Silenta-SVT** – equipped with a pull cord switch and a regulated timer with the operating time adjustable from 2 to 30 minutes.



**Silenta-SVTH** – equipped with a pull cord switch, regulated timer with the operating time adjustable from 2 to 30 minutes and a humidity sensor with the operating threshold range from 60% to 90%.

### Control

#### Manual:

- The fan is controlled by a room light switch. It is not included in the delivery package.
- The fan is controlled by the built-in pull cord switch **V**. Not applied in case of ceiling mounting.
- Speed control is possible through a thyristor speed controller (see Electrical Accessories). Several fans may connected to the same regulator unit.

#### Automatic:

- By the electronic control unit **BU-1-60** (see Electrical Accessories). The control unit is supplied separately.
- By the timer **T** (the built-in run-out timer enables the fan operation within 2 to 30 minutes after the fan switching off).
- By the humidity sensor and timer **TH** (if the humidity level in the room exceeds the sensor threshold adjustable value within 60-90% the fan switches automatically on and operates until the humidity level drops to the standard level, after that the fan continues operating within the time period according to the timer setting, then shuts down).

### Mounting features

- The fan is mounted directly into the ventilation shaft.
- Flexible duct application is recommended in case of remote location of the ventilation shaft. The air duct is connected to the fan exhaust flange through a clamp.
- Fixed to wall by self-tapping screws.
- Suitable for ceiling mounting.

### Accessories



Air ducts

Grilles and hoods

Backdraft damper

Speed controllers

Clamps

### Aerodynamic characteristics

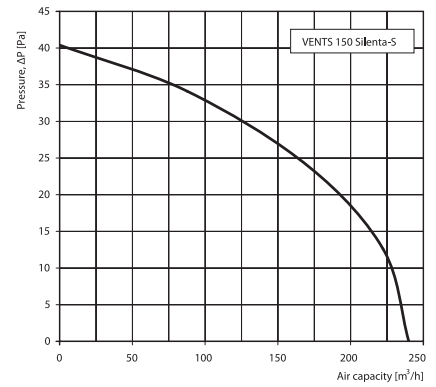
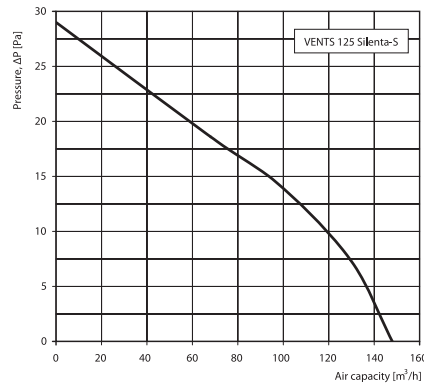
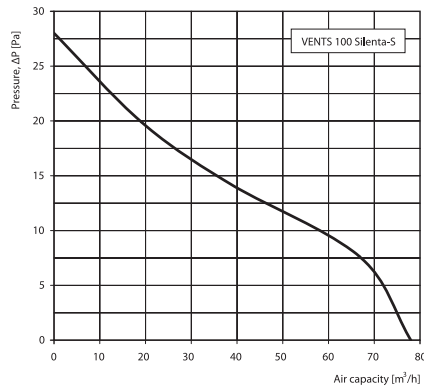

### Technical data

Model	Voltage [V] at 50 Hz	Power Consumption [W]	Current [A]	Maximum air capacity [m³/h]	Sound Pressure Level at 3 m [dB(A)]	Weight [kg]
VENTS 100 Silenta-S	230	5,6	0,035	78	26	0,52
VENTS 125 Silenta-S	230	9,3	0,06	148	31	0,69
VENTS 150 Silenta-S	230	20	0,14	240	33	0,85

### Overall dimensions

Model	Dimensions [mm]				
	∅ D	B	H	L	L1
VENTS 100 Silenta-S	100	150	120	108	12
VENTS 125 Silenta-S	125	176	140	114	13
VENTS 150 Silenta-S	150	205	165	132	14

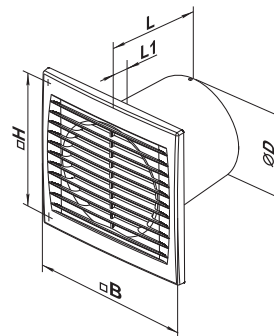

### Mounting example



### Certificates

IP 34 The fans meet the applicable safety and electromagnetic compatibility standards.

# AXIAL INLINE FANS

## ▶ VENTS VKO and VKOk Series



Axial inline fans, for exhaust or supply ventilation with the capacity up to 358 m<sup>3</sup>/h. Compatible with Ø 100, 125 and 150 mm air ducts.

## ▶ VENTS VKO1 and VKO1k Series



Axial inline fans, for exhaust or supply ventilation with the capacity up to 365 m<sup>3</sup>/h. Compatible with Ø 100, 125 and 150 mm air ducts.



**Axial inline fans  
VENTS VKO Series**

Air capacity up to 358 m<sup>3</sup>/h

page  
32



**Axial inline fans with a fixing bracket  
VENTS VKOk Series**

Air capacity up to 358 m<sup>3</sup>/h

page  
32



**Axial inline fans  
VENTS VKO1 Series**

Air capacity up to 365 m<sup>3</sup>/h

page  
34



**Axial inline fans with a fixing bracket  
VENTS VKO1k Series**

Air capacity up to 365 m<sup>3</sup>/h

page  
34



## VENTS VKO Series



Axial inline fans,  
for exhaust or supply ventilation  
with the capacity up to 358 m<sup>3</sup>/h

### Applications

- Continuous or periodic exhaust ventilation of bathroom, showers, kitchens and other utility spaces.
- Exhaust or supply ventilation depending on the fan mounting type in the system.
- Designed for PVC ducting systems or flexible ducts.
- Low to medium air flow motion for short distances at low air resistance.
- Compatible with Ø 100, 125 and 150 mm air ducts.

### Design

- The casing and the impeller are made of high-quality durable ABS plastic, UV resistant.
- The intellectual impeller design makes the fan efficiency high and the service life long.
- Protection rating IP X4.

### Motor

- Reliable and low-watt electric motor.
- Designed for continuous operation and requires no maintenance.
- Equipped with overheating protection.

### Modifications and Options

**VKOk** – fan with a fixing bracket for flat surface mounting.



**VKO L** – the motor is equipped with ball bearings for long service life (appr. 40 thousand hours) and fan mounting at any angle. The bearings are maintenance-free and contain enough grease for the entire operating period.



**VKO turbo** – high-powered motor.



**VKO press** – 5-blade low-noise impeller with improved aerodynamics for higher fan capacity.



**VKO 12** – modification with low-voltage motor. 12 V AC power supply.

### Control

#### Manual:

- The fan is controlled by a room light switch. It is not included in the delivery package.
- Speed control is possible through a thyristor speed controller (see Electrical Accessories). Several fans may be connected to the same regulator unit.

#### Automatic:

- By the electronic control unit **BU-1-60** (see Electrical Accessories). The control unit is supplied separately.

### Mounting features

- The fan is mounted into a matching duct size. Fastening with clamps in case of flexible duct connection.
- This series fans have different intake and exhaust flange diameters to enable attachment of the decorative grille **MV** to the appropriate intake flange diameter in case of direct installation into the ventilation shaft or instead of the existing ventilation grille.
- The fan can be mounted on a horizontal or vertical flat surface by a fixing bracket (**VKOk** model).
- Two fans can be installed in series for higher performance.
- For 12 V low-voltage motor fan connection to 220 V / 50 Hz power mains use the step-down transformer TRF 220/12-25 that is available upon separate order.

### Mounting examples



VKO fan flat ventilation example



VKOk fan cottage ventilation example

### Accessories



### Aerodynamic characteristics

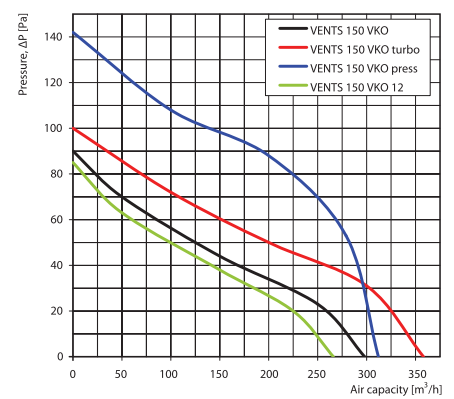
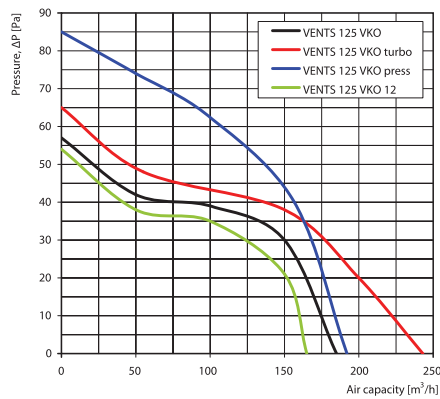
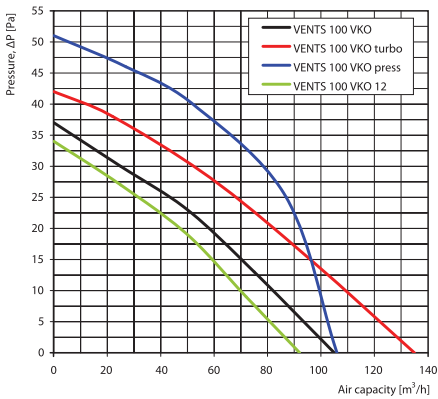

### Technical data

Model	Voltage [V] at 50 Hz	Power Consumption [W]	Current [A]	r.p.m.	Maximum air capacity [m³/h]	Sound Pressure Level at 3 m [dB(A)]	Weight [kg]
VENTS 100 VKO	220-240	14	0,085	2300	105	37	0,41
VENTS 125 VKO	220-240	16	0,1	2400	185	38	0,48
VENTS 150 VKO	220-240	24	0,13	2400	298	40	0,80
VENTS 100 VKO turbo	220-240	16	0,1	2300	135	38	0,41
VENTS 125 VKO turbo	220-240	24	0,105	2400	243	39	0,48
VENTS 150 VKO turbo	220-240	30	0,13	2400	358	44	0,80
VENTS 100 VKO press	220-240	16	0,1	2300	106	39	0,41
VENTS 125 VKO press	220-240	24	0,105	2400	192	39	0,48
VENTS 150 VKO press	220-240	30	0,13	2400	312	44	0,80
VENTS 100 VKO 12	12	14	1,5	2200	92	36	0,40
VENTS 125 VKO 12	12	16	1,33	2300	165	37	0,46
VENTS 150 VKO 12	12	24	2	2300	266	39	0,76

### Overall dimensions

Model	Dimensions [mm]								
	∅ D	∅ D1	B	B1	H	L	L1	L2	L3
VENTS 100 VKO	100	104	—	—	—	91	31	—	—
VENTS 125 VKO	125	129	—	—	—	93	31	—	—
VENTS 150 VKO	150	154	—	—	—	108	46	—	—
VENTS 100 VKOk	100	104	160	144	114	91	31	45	29
VENTS 125 VKOk	125	129	185	169	139	93	31	45	29
VENTS 150 VKOk	150	154	200	184	163	108	46	45	29

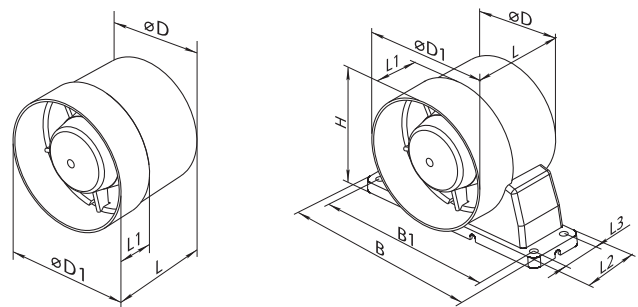

### Certificates



The fans meet the applicable safety and electromagnetic compatibility standards.

## VENTS VKO1 Series



Axial inline fans, for exhaust or supply ventilation with the capacity up to 365 m<sup>3</sup>/h

### Applications

- Continuous or periodic exhaust ventilation of bathroom, showers, kitchens and other utility spaces.
- Exhaust or supply ventilation depending on the fan mounting type in the system.
- Designed for PVC ducting systems or flexible ducts.
- Low to medium air flow motion for short distances at low air resistance.
- Compatible with Ø 100, 125 and 150 mm air ducts.

### Mounting examples



VKO1k fan cottage ventilation example



VKO1 fan flat ventilation example

### Design

- The casing and the impeller are made of high-quality durable ABS plastic, UV resistant.
- The intellectual impeller design makes the fan efficiency high and the service life long.
- Protection rating IP X4.

### Motor

- Reliable and low-watt electric motor.
- Designed for continuous operation and requires no maintenance.
- Equipped with overheating protection.

### Modifications and Options

**VKO1k** – fan with a fixing bracket for flat surface mounting.



**VKO1 L** – the motor is equipped with ball bearings for long service life (appr. 40 thousand hours) and fan mounting at any angle. The bearings are maintenance-free and contain enough grease for the entire operating period.



**VKO1 turbo** – high-powered motor.



**VKO1 press** – 5-blade low-noise impeller with improved aerodynamics for higher fan capacity.



**VKO1 12** – modification with low-voltage motor. 12 V AC power supply.



**VKO1 T** – equipped with a regulated timer with the operating time from 2 to 30 minutes.

### Control

#### Manual:

- The fan is controlled by a room light switch. It is not included in the delivery package.
- Speed control is possible through a thyristor speed controller (see Electrical Accessories). Several fans may be connected to the same regulator unit.

#### Automatic:

- By the electronic control unit **BU-1-60** (see Electrical Accessories). The control unit is supplied separately.
- By the timer **T** (the built-in run-out timer enables the fan operation within 2 to 30 minutes after the fan switching off).

### Mounting features

- The fan is mounted into a matching duct size. Fastening with clamps in case of flexible duct connection.
- The mounting bracket enables fan installation on both horizontal and vertical flat surfaces (**VKO1k** model).
- Two fans can be installed in series for higher performance.
- For 12 V low-voltage motor fan connection to 220 V / 50 Hz power mains use the step-down transformer TRF 220/12-25 that is available upon separate order.

### Accessories



### Aerodynamic characteristics

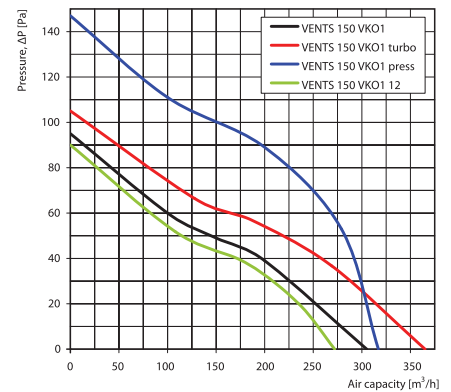
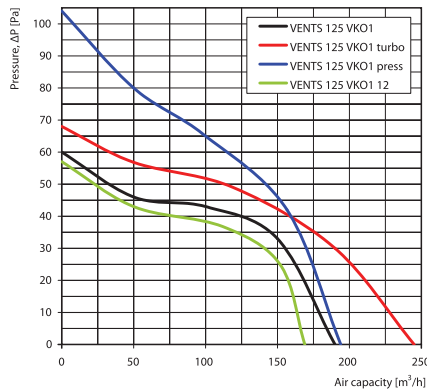
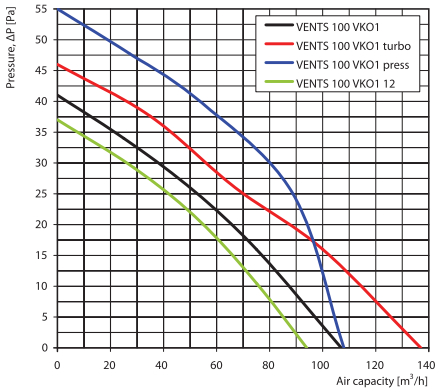

### Technical data

Model	Voltage [V] at 50 Hz	Power Consumption [W]	Current [A]	r.p.m.	Maximum air capacity [m³/h]	Sound Pressure Level at 3 m [dB(A)]	Weight [kg]
VENTS 100 VKO1	220-240	14	0,085	2300	107	36	0,41
VENTS 125 VKO1	220-240	16	0,1	2400	190	38	0,43
VENTS 150 VKO1	220-240	30	0,13	2400	305	40	0,80
VENTS 100 VKO1 turbo	220-240	16	0,1	2300	137	37	0,49
VENTS 125 VKO1 turbo	220-240	24	0,105	2400	245	39	0,51
VENTS 150 VKO1 turbo	220-240	36	0,16	2400	365	42	0,58
VENTS 100 VKO1 press	220-240	16	0,1	2300	108	39	0,41
VENTS 125 VKO1 press	220-240	24	0,105	2400	194	39	0,43
VENTS 150 VKO1 press	220-240	36	0,16	2400	317	42	0,80
VENTS 100 VKO1 12	12	14	1,5	2200	94	35	0,40
VENTS 125 VKO1 12	12	16	1,7	2300	169	37	0,41
VENTS 150 VKO1 12	12	24	2	2300	272	39	0,76

### Overall dimensions

Model	Dimensions [mm]								
	∅ D	∅ d	B	B1	H	L	L1	L2	L3
VENTS 100 VKO1	100	59	—	—	—	85	28	—	—
VENTS 125 VKO1	125	59	—	—	—	90	28	—	—
VENTS 150 VKO1	150	59	—	—	—	100	28	—	—
VENTS 100 VKO1k	100	59	160	144	110	85	28	45	29
VENTS 125 VKO1k	125	59	185	169	125	90	28	45	29
VENTS 150 VKO1k	150	59	200	184	162	100	28	45	29

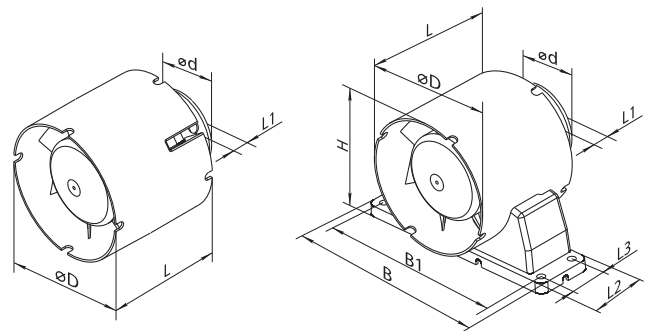

### Certificates



The fans meet the applicable safety and electromagnetic compatibility standards.

# AXIAL WALL- AND CEILING-MOUNTED FANS

Axial fans for exhaust ventilation with the capacity up to 365 m<sup>3</sup>/h. Compatible with Ø 100, 125 or 150 mm air ducts. Some models are equipped with automatic or manual louver shutters. Wide range of designs and options.



## **Axial fans VENTS M Series**

Air capacity up to 345 m<sup>3</sup>/h

page  
38



## **Axial fans VENTS M3 Series**

Air capacity up to 345 m<sup>3</sup>/h

page  
40



## **Axial fans VENTS M1 Series**

Air capacity up to 345 m<sup>3</sup>/h

page  
42



## **Axial fans with automatic louvre shutters VENTS MA Series**

Air capacity up to 345 m<sup>3</sup>/h

page  
44



## **Axial wall and ceiling fans VENTS MA reverse Series**

Air capacity up to 202 m<sup>3</sup>/h

page  
46



## **Axial fans VENTS X1 Series**

Air capacity up to 365 m<sup>3</sup>/h

page  
48



## **Axial fans VENTS F Series**

Air capacity up to 232 m<sup>3</sup>/h

page  
50



**AXIAL FANS  
VENTS F1 Series**

Air capacity up to 232 m<sup>3</sup>/h

page  
52



**AXIAL FANS  
VENTS K Series**

Air capacity up to 341 m<sup>3</sup>/h

page  
54



**AXIAL FANS  
VENTS K1 Series**

Air capacity up to 226 m<sup>3</sup>/h

page  
56



**AXIAL FANS  
VENTS PF Series**

Air capacity up to 342 m<sup>3</sup>/h

page  
58



**AXIAL FANS  
VENTS PF1 Series**

Air capacity up to 349 m<sup>3</sup>/h

page  
60



**AXIAL FANS  
VENTS S Series**

Air capacity up to 341 m<sup>3</sup>/h

page  
62



**AXIAL FANS  
VENTS D Series**

Air capacity up to 341 m<sup>3</sup>/h

page  
64

## VENTS M Series



Axial fans for exhaust ventilation with the capacity up to 345 m<sup>3</sup>/h

### Applications

- Continuous or periodic exhaust ventilation of bathroom, showers, kitchens and other utility spaces.
- Ventilation shaft mounting or duct connection.
- Low to medium air flow motion for short distances at low air resistance.
- Compatible with Ø 100, 125 and 150 mm air ducts.

### Design

- Modern design and aesthetic look.
- The casing and the impeller are made of high-quality durable ABS plastic, UV resistant.
- The intellectual impeller design makes the fan efficiency high and the service life long.
- Protection rating IP 34.

### Motor

- Reliable and low-watt electric motor.
- Designed for continuous operation and requires no maintenance.
- Equipped with overheating protection.

### Modifications and Options



**MK** – fan is equipped with a backdraft damper for back flow preventing.



**ML** – the motor is equipped with ball bearings for long service life (appr. 40 thousand hours) and fan mounting at any angle. The bearings are maintenance-free and contain enough grease for the entire operating period.



**M turbo** – high-powered motor.



**M press** – 5-blade low-noise impeller with improved aerodynamics for higher fan capacity.



**M 12** – modification with low-voltage motor. 12 V AC power supply.



**MT** – equipped with a regulated timer with the operating time from 2 to 30 minutes.



**MTH** – equipped with a timer with the operating time from 2 to 30 minutes and a humidity sensor with the threshold value from 60 to 90%.



**MV** – equipped with a pull cord switch.



**MVT** – equipped with a pull cord switch and a regulated timer with the operating time adjustable from 2 to 30 minutes.



**MVTH** – equipped with a pull cord switch, regulated timer with the operating time adjustable from

2 to 30 minutes and a humidity sensor with the operating threshold range from 60% to 90%.



**MTP** – equipped with a regulated timer and a motion sensor with the sensitivity area from 1 to 4 m and the detection angle up to 100°.

### Control

#### Manual:

- The fan is controlled by a room light switch. It is not included in the delivery package.
- The fan is controlled by the built-in pull cord switch **V**. Not applied in case of ceiling mounting.
- Speed control is possible through a thyristor speed controller (see Electrical Accessories). Several fans may be connected to the same regulator unit.

#### Automatic:

- By the electronic control unit **BU-1-60** (see Electrical Accessories). The control unit is supplied separately.
- By the timer **T** (the built-in run-out timer enables the fan operation within 2 to 30 minutes after the fan switching off).
- By the humidity sensor and timer **TH** (if the humidity level in the room exceeds the sensor threshold adjustable value within 60-90% the fan switches automatically on and operates until the humidity level drops to the standard level, after that the fan continues operating within the time period according to the timer setting, then shuts down).
- By the motion sensor and the timer **TP** (in case of motion detection the fan switches automatically on and operates within the set time period from 2 to 30 minutes. The motion sensitivity area is up to 4 meters and the maximum detection angle is 100°).

### Mounting features

- The fan is mounted directly into the ventilation shaft or used for ceiling mounting with the connection to the duct.
- Flexible duct application is recommended in case of remote location of the ventilation shaft. The air duct is connected to the fan exhaust flange through a clamp.
- Fixed to wall by self-tapping screws.
- For 12 V low-voltage motor fan connection to 220 V / 50 Hz power mains use the step-down transformer TRF 220/12-25 that is available upon separate order.

### Accessories



### Aerodynamic characteristics

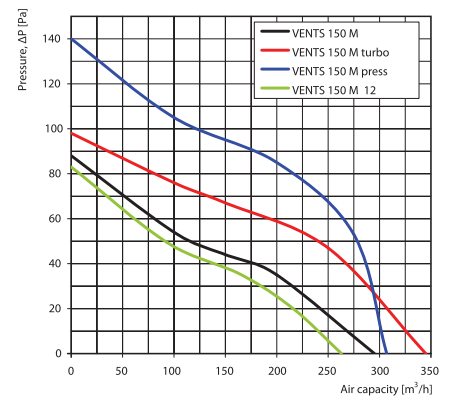
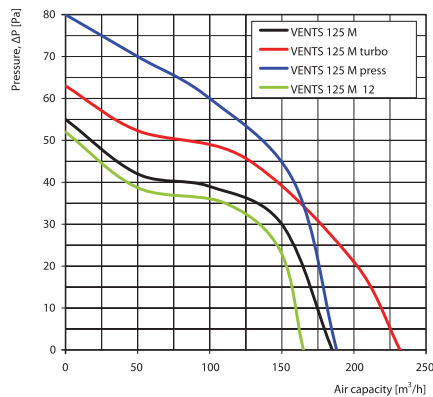
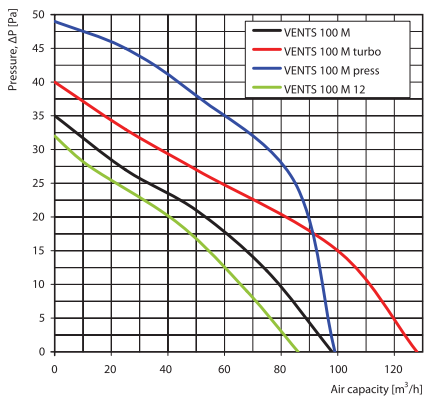

### Technical data

Model	Voltage [V] at 50 Hz	Power Consumption [W]	Current [A]	r.p.m.	Maximum air capacity [m³/h]	Sound Pressure Level at 3 m [dB(A)]	Weight [kg]
VENTS 100 M	220-240	14	0,085	2300	98	34	0,55
VENTS 125 M	220-240	16	0,1	2400	185	35	0,70
VENTS 150 M	220-240	24	0,13	2400	295	39	0,89
VENTS 100 M turbo	220-240	16	0,1	2300	128	37	0,57
VENTS 125 M turbo	220-240	22	0,105	2400	232	37	0,72
VENTS 150 M turbo	220-240	30	0,13	2400	345	41	0,93
VENTS 100 M press	220-240	16	0,1	2300	99	37	0,65
VENTS 125 M press	220-240	22	0,105	2400	188	39	0,81
VENTS 150 M press	220-240	30	0,13	2400	307	41	0,99
VENTS 100 M 12	12	14	1,5	2200	86	33	0,50
VENTS 125 M 12	12	16	1,7	2300	165	34	0,70
VENTS 150 M 12	12	24	2	2300	263	38	

### Mounting example



M fan kitchen ventilation example

### Overall dimensions

Model	Dimensions [mm]				
	Ø D	B	H	L	L1
VENTS 100 M	100	159	135	88,5	23
VENTS 125 M	125	180	150	94	25
VENTS 150 M	150	206	182	106	25,5

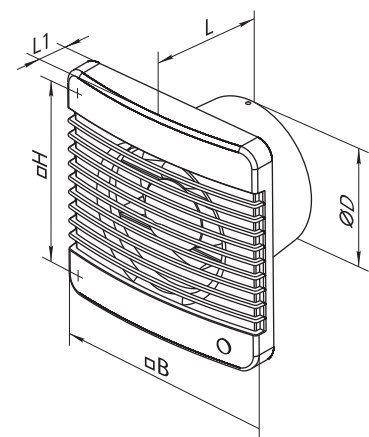

### Certificates



The fans meet the applicable safety and electromagnetic compatibility standards.



## VENTS M3 Series



Axial fans for exhaust ventilation with the capacity up to 345 m<sup>3</sup>/h

### Applications

- Continuous or periodic exhaust ventilation of bathroom, showers, kitchens and other utility spaces.
- Ventilation shaft mounting or duct connection.
- For rectangular ventilation shafts.
- Low to medium air flow motion for short distances at low air resistance.
- Compatible with Ø 100, 125 and 150 mm air ducts.

### Design

- Modern design and aesthetic look.
- The casing and the impeller are made of high-quality durable ABS plastic, UV resistant.
- The intellectual impeller design makes the fan efficiency high and the service life long.
- Protection rating IP 34.

### Motor

- Reliable and low-watt electric motor.
- Designed for continuous operation and requires no maintenance.
- Equipped with overheating protection.

### Modifications and Options



**M3 K** – fan is equipped with a backdraft damper for back flow preventing.



**M3 L** – the motor is equipped with ball bearings for long service life (appr. 40 thousand hours) and fan mounting at any angle. The bearings are maintenance-free and contain enough grease for the entire operating period.



**M3 turbo** – high-powered motor.



**M3 press** – 5-blade low-noise impeller with improved aerodynamics for higher fan capacity.



**M3 12** – modification with low-voltage motor. 12 V AC power supply.



**M3T** – equipped with a regulated timer with the operating time from 2 to 30 minutes.



**M3TH** – equipped with a timer with the operating time from 2 to 30 minutes and a humidity sensor with the threshold value from 60 to 90%.



**M3V** – equipped with a pull cord switch.



**M3VT** – equipped with a pull cord switch and a regulated timer with the operating time adjustable from 2 to 30 minutes.



**M3VTH** – equipped with a pull cord switch, regulated timer with the operating time adjustable from 2 to 30 minutes and a humidity sensor with the operating threshold range from 60% to 90%.



**M3TP** – equipped with a regulated timer and a motion sensor with the sensitivity area from 1 to 4 m and the detection angle up to 100°.

### Control

#### Manual:

- The fan is controlled by a room light switch. It is not included in the delivery package.
- The fan is controlled by the built-in pull cord switch **V**. Not applied in case of ceiling mounting.
- Speed control is possible through a thyristor speed controller (see Electrical Accessories). Several fans may connected to the same regulator unit.

#### Automatic:

- By the electronic control unit **BU-1-60** (see Electrical Accessories). The control unit is supplied separately.
- By the timer **T** (the built-in run-out timer enables the fan operation within 2 to 30 minutes after the fan switching off).
- By the humidity sensor and timer **TH** (if the humidity level in the room exceeds the sensor threshold adjustable value within 60-90% the fan switches automatically on and operates until the humidity level drops to the standard level, after that the fan continues operating within the time period according to the timer setting, then shuts down).
- By the motion sensor and the timer **TP** (in case of motion detection the fan switches automatically on and operates within the set time period from 2 to 30 minutes. The motion sensitivity area is up to 4 meters and the maximum detection angle is 100°).

### Mounting features

- The fan is mounted directly into the ventilation shaft or wall mounted and connected to the air ducts.
- The enlarged front grille modification makes the fan suitable for mounting into rectangular ventilation shafts.
- Flexible duct application is recommended in case of remote location of the ventilation shaft. The air duct is connected to the fan exhaust flange through a clamp.
- Fixed to wall by self-tapping screws.
- For 12 V low-voltage motor fan connection to 220 V / 50 Hz power mains use the step-down transformer TRF 220/12-25 that is available upon separate order.

### Accessories



Air ducts

Grilles and hoods

Backdraft damper

Speed controllers

Clamps

## Aerodynamic characteristics

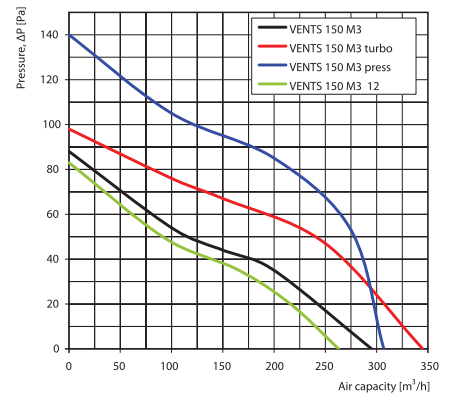
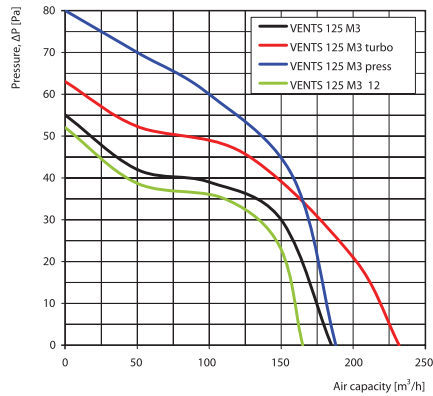
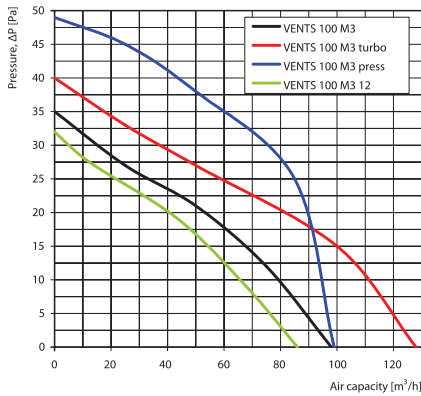

## Technical data

Model	Voltage [V] at 50 Hz	Power Consumption [W]	Current [A]	r.p.m.	Maximum air capacity [m³/h]	Sound Pressure Level at 3 m [dB(A)]	Weight [kg]
VENTS 100 M3	220-240	14	0,085	2300	98	34	0,61
VENTS 125 M3	220-240	16	0,1	2400	185	35	0,80
VENTS 150 M3	220-240	24	0,13	2400	295	39	0,95
VENTS 100 M3 turbo	220-240	16	0,1	2300	128	37	0,69
VENTS 125 M3 turbo	220-240	22	0,105	2400	232	40	0,86
VENTS 150 M3 turbo	220-240	30	0,13	2400	345	43	1,01
VENTS 100 M3 press	220-240	16	0,1	2300	99	37	0,69
VENTS 125 M3 press	220-240	22	0,105	2400	188	39	0,87
VENTS 150 M3 press	220-240	30	0,13	2400	307	41	1,03
VENTS 100 M3 12	12	14	1,5	2200	86	33	0,60
VENTS 125 M3 12	12	16	1,7	2300	165	34	0,78
VENTS 150 M3 12	12	24	2	2300	263	38	0,91

## Mounting example



## Overall dimensions

Model	Dimensions [mm]						
	Ø D	B	B1	H	H1	L	L1
VENTS 100 M3	100	185	155	256	226	86	30
VENTS 125 M3	125	185	155	256	226	89	30
VENTS 150 M3	150	185	155	256	226	114	30

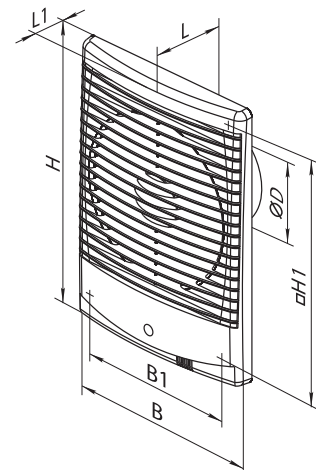

## Certificates



The fans meet the applicable safety and electromagnetic compatibility standards.

## VENTS M1 Series



Axial fans for exhaust ventilation with the capacity up to 345 m<sup>3</sup>/h

### Applications

- Continuous or periodic exhaust ventilation of bathroom, showers, kitchens and other utility spaces.
- Ventilation shaft mounting or duct connection.
- Low to medium air flow motion for short distances at low air resistance.
- Compatible with Ø 100, 125 and 150 mm air ducts.

### Design

- Modern design and aesthetic look.
- The casing and the impeller are made of high-quality durable ABS plastic, UV resistant.
- The intellectual impeller design makes the fan efficiency high and the service life long.
- Insect screen.
- Protection rating IP 34.

### Motor

- Reliable and low-watt electric motor.
- Designed for continuous operation and requires no maintenance.
- Equipped with overheating protection.

### Modifications and Options



**M1 K** – fan is equipped with a backdraft damper for back flow preventing.



**M1 L** – The motor is equipped with ball bearings for long service life (appr. 40 thousand hours) and fan mounting at any angle. The bearings are maintenance-free and contain enough grease for the entire operating period.



**M1 turbo** – high-powered motor.



**M1 press** – 5-blade low-noise impeller with improved aerodynamics for higher fan capacity.



**M1 12V** – modification with low-voltage motor. 12 V AC power supply.



**M1T** – equipped with a regulated timer with the operating time from 2 to 30 minutes.



**M1TH** – equipped with a timer with the operating time from 2 to 30 minutes and a humidity sensor with the threshold value from 60 to 90%.



**M1V** – equipped with a pull cord switch.



**M1VT** – equipped with a pull cord switch and a regulated timer with the operating time adjustable from 2 to 30 minutes.



**M1VTH** – equipped with a pull cord switch, regulated timer with the operating time adjustable from 2 to 30 minutes and a humidity sensor with the operating threshold range from 60% to 90%.



**M1TP** – equipped with a regulated timer and a motion sensor with the sensitivity area from 1 to 4 m and the detection angle up to 100°.

### Control

#### Manual:

- The fan is controlled by a room light switch. It is not included in the delivery package.
- The fan is controlled by the built-in pull cord switch **V**. Not applied in case of ceiling mounting.
- Speed control is possible through a thyristor speed controller (see Electrical Accessories). Several fans may connected to the same regulator unit.

#### Automatic:

- By the electronic control unit **BU-1-60** (see Electrical Accessories). The control unit is supplied separately.
- By the timer **T** (the built-in run-out timer enables the fan operation within 2 to 30 minutes after the fan switching off).
- By the humidity sensor and timer **TH** (if the humidity level in the room exceeds the sensor threshold adjustable value within 60-90% the fan switches automatically on and operates until the humidity level drops to the standard level, after that the fan continues operating within the time period according to the timer setting, then shuts down).
- By the motion sensor and the timer **TP** (in case of motion detection the fan switches automatically on and operates within the set time period from 2 to 30 minutes. The motion sensitivity area is up to 4 meters and the maximum detection angle is 100°).

### Mounting features

- The fan is mounted directly into the ventilation shaft.
- Flexible duct application is recommended in case of remote location of the ventilation shaft. The air duct is connected to the fan exhaust flange through a clamp.
- Fixed to wall by self-tapping screws.
- For 12 V low-voltage motor fan connection to 220 V / 50 Hz power mains use the step-down transformer TRF 220/12-25 that is available upon separate order.

### Accessories



### Aerodynamic characteristics

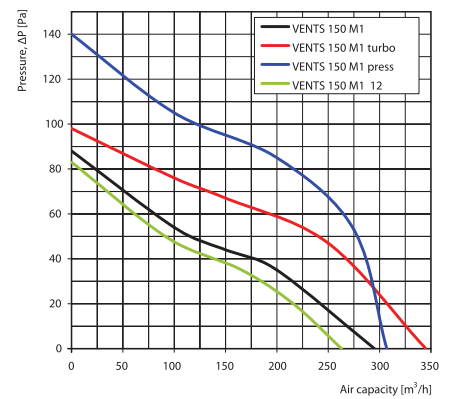
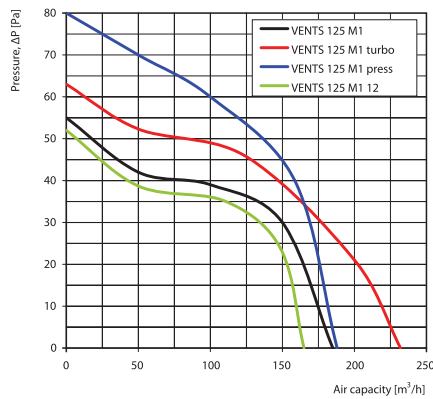
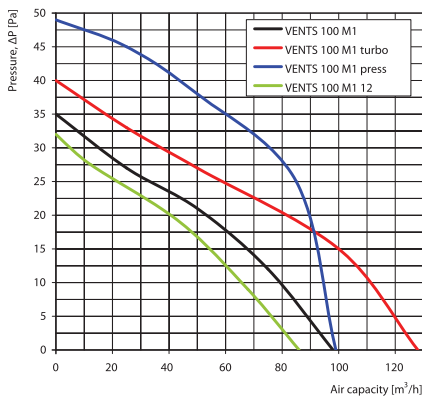

### Technical data

Model	Voltage [V] at 50 Hz	Power Consumption [W]	Current [A]	r.p.m.	Maximum air capacity [m³/h]	Sound Pressure Level at 3 m [dB(A)]	Weight [kg]
VENTS 100 M1	220-240	14	0,085	2300	98	34	0,51
VENTS 125 M1	220-240	16	0,1	2400	185	35	0,68
VENTS 150 M1	220-240	24	0,13	2400	295	39	0,80
VENTS 100 M1 turbo	220-240	16	0,1	2300	128	37	0,65
VENTS 125 M1 turbo	220-240	22	0,105	2400	232	40	0,81
VENTS 150 M1 turbo	220-240	30	0,13	2400	345	43	0,99
VENTS 100 M1 press	220-240	16	0,1	2300	99	37	0,65
VENTS 125 M1 press	220-240	22	0,105	2400	188	39	0,81
VENTS 150 M1 press	220-240	30	0,13	2400	307	41	0,99
VENTS 100 M1 12	12	14	1,5	2200	86	33	0,51
VENTS 125 M1 12	12	16	1,7	2300	165	34	0,68
VENTS 150 M1 12	12	24	2	2300	262	38	0,76

### Mounting example



### Overall dimensions

Model	Dimensions [mm]						
	∅ D	B	B1	B2	H	L	L1
VENTS 100 M1	100	165	150	150	150	92	32
VENTS 125 M1	125	190	174	128	173	98	33
VENTS 150 M1	150	212	196	150	195	114	33

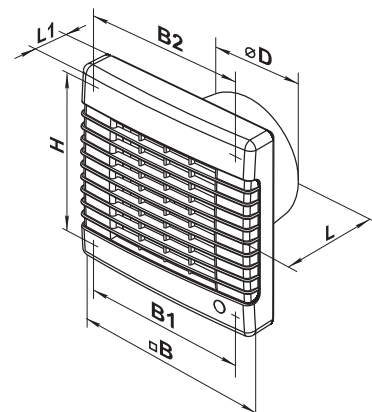

### Certificates



The fans meet the applicable safety and electromagnetic compatibility standards.

## VENTS MA Series



Axial fans with automatic louver shutters for exhaust ventilation with the capacity up to 345 m<sup>3</sup>/h

### Applications

- Continuous or periodic exhaust ventilation of bathroom, showers, kitchens and other utility spaces.
- Ventilation shaft mounting or duct connection.
- Low to medium air flow motion for short distances at low air resistance.
- Compatible with Ø 100, 125 and 150 mm air ducts.



Fan OFF - louver shutters CLOSED



Fan ON - louver shutters OPEN

### Design

- Modern design and aesthetic look.
- The casing and the impeller are made of high-quality durable ABS plastic, UV resistant.
- The intellectual impeller design makes the fan efficiency high and the service life long.
- Fan is equipped with a thermal actuator that provides smooth opening and shutting of automatic louver shutters for air back flow preventing.
- Protection rating IP 24.

### Motor

- Reliable and low-watt electric motor.
- Designed for continuous operation and requires no maintenance.
- Equipped with overheating protection.

### Modifications and Options



**MAL** – the motor is equipped with ball bearings for long service life (appr. 40 thousand hours) and fan mounting at any angle. The bearings are maintenance-free and contain enough grease for the entire operating period.



**MA turbo** – high-powered motor.



**MA press** – 5-blade low-noise impeller with improved aerodynamics for higher fan capacity.



**MA 12** – modification with low-voltage motor. 12 V AC power supply.



**MAT** – equipped with a regulated timer with the operating time from 2 to 30 minutes.



**MATH** – equipped with a timer with the operating time from 2 to 30 minutes and a humidity sensor with the threshold value from 60 to 90%.



**MAV** – equipped with a pull cord switch.



**MAVT** – equipped with a pull cord switch and a regulated timer with the operating time adjustable from 2 to 30 minutes.



**MAVTH** – equipped with a pull cord switch, regulated timer with the operating time adjustable from 2 to 30 minutes and a humidity sensor with the operating threshold range from 60% to 90%.



**MATP** – equipped with a regulated timer and a motion sensor with the sensitivity area from 1 to 4 m and the detection angle up to 100°.

### Control

#### Manual:

- The fan is controlled by a room light switch. It is not included in the delivery package.
- The fan is controlled by the built-in pull cord switch **V**. Not applied in case of ceiling mounting.
- Speed control is possible through a thyristor speed controller (see Electrical Accessories). Several fans may be connected to the same regulator unit.

#### Automatic:

- By the electronic control unit **BU-1-60** (see Electrical Accessories). The control unit is supplied separately.
- By the timer **T** (the built-in run-out timer enables the fan operation within 2 to 30 minutes after the fan switching off).
- By the humidity sensor and timer **TH** (if the humidity level in the room exceeds the sensor threshold adjustable value within 60-90% the fan switches automatically on and operates until the humidity level drops to the standard level, after that the fan continues operating within the time period according to the timer setting, then shuts down).
- By the motion sensor and the timer **TP** (in case of motion detection the fan switches automatically on and operates within the set time period from 2 to 30 minutes. The motion sensitivity area is up to 4 meters and the maximum detection angle is 100°).

### Mounting features

- The fan is mounted directly into the ventilation shaft.
- Flexible duct application is recommended in case of remote location of the ventilation shaft. The air duct is connected to the fan exhaust flange through a clamp.
- Fixed to wall by self-tapping screws.
- Suitable for ceiling mounting.
- Flange of 92 mm length for easy mounting into concrete walls and floor decks up to 100 mm thick.
- For 12 V low-voltage motor fan connection to 220 V / 50 Hz power mains use the step-down transformer TRF 220/12-25 that is available upon separate order.

### Accessories

Air ducts



Grilles and hoods



Speed controllers



Clamps



## Aerodynamic characteristics

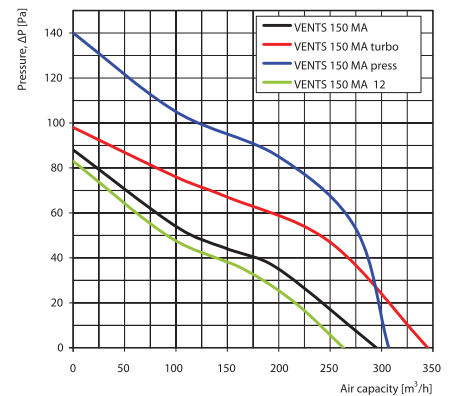
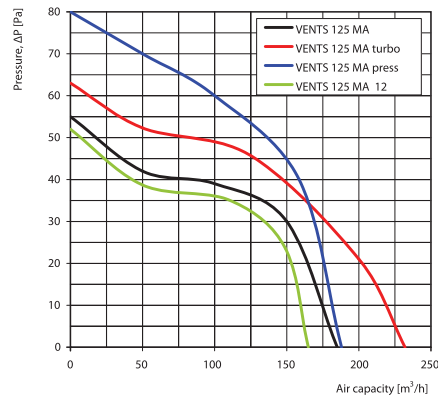
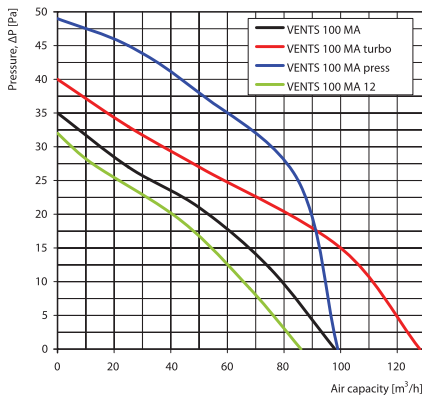

## Technical data

Model	Voltage [V] at 50 Hz	Power Consumption [W]	Current [A]	r.p.m.	Maximum air capacity [m³/h]	Sound Pressure Level at 3 m [dB(A)]	Weight [kg]
VENTS 100 MA	220-240	18	0,085	2300	98	34	0,65
VENTS 125 MA	220-240	22	0,1	2400	185	35	0,75
VENTS 150 MA	220-240	26	0,13	2400	295	39	1,02
VENTS 100 MA turbo	220-240	20	0,1	2300	128	37	0,65
VENTS 125 MA turbo	220-240	30	0,13	2400	232	37	0,81
VENTS 150 MA turbo	220-240	32	0,13	2400	345	41	0,99
VENTS 100 MA press	220-240	20	0,1	2300	99	37	0,65
VENTS 125 MA press	220-240	30	0,13	2400	188	39	0,81
VENTS 150 MA press	220-240	32	0,14	2400	307	41	0,99
VENTS 100 MA 12	12	18	1,5	2200	86	33	0,65
VENTS 125 MA 12	12	22	1,7	2300	165	34	0,75
VENTS 150 MA 12	12	24	2	2300	263	38	0,98

## Mounting example



## Overall dimensions

Model	Dimensions [mm]						
	∅ D	B	B1	B2	H	L	L1
VENTS 100 MA	100	165	150	150	150	92	32
VENTS 125 MA	125	190	174	128	173	98	33
VENTS 150 MA	150	212	196	150	195	114	33

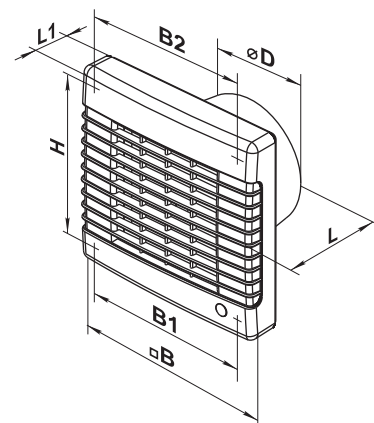

## Certificates



The fans meet the applicable safety and electromagnetic compatibility standards.

## VENTS MA reverse Series



Axial reverse fans for exhaust and supply ventilation with the capacity up to 202 m<sup>3</sup>/h

### Applications

- Continuous or periodic exhaust and supply ventilation of bathrooms, showers, kitchens, garages and other residential spaces.
- Mounting on the external wall together with ventilation kit that includes an air duct and an external grille provides the most efficient operation.
- Compatible with Ø 150 mm air ducts.

### Design

- Modern design and aesthetic look.
- The casing and the impeller are made of high-quality durable ABS plastic, UV resistant.
- The intellectual impeller design makes the fan efficiency high and the service life long.
- Fan is equipped with a thermal actuator that provides smooth opening and shutting of automatic louver shutters for air back flow preventing.
- Supplied with a three bottom control unit and 220 V - 12 V transformer.
- Transformer provides reliable fan operation with safe power supply 12 V.
- Protection rating IP 24.

### Motor

- Reliable DC motor (12 V) with low energy demand.
- Two-speed reverse DC motor provides fan operation both in supply and exhaust mode.
- Special motor design ensures low noise level.
- Designed for continuous operation and requires no maintenance.
- Equipped with overheating protection.

### Control

#### Manual:

- Three bottom control unit (included into delivery set) with integrated circuit board is used for:
  1. On/off switching;
  2. Fan speed switching (min - max);
  3. Fan operation mode switching (exhaust - supply mode).

### Mounting features

- Fan is designed for indoor mounting on the external wall and is connected to the air duct.
- Fastening with screws. Flexible air duct is connected to exhaust flange with a clamp.



Fan off - louver shutters CLOSED



Control unit

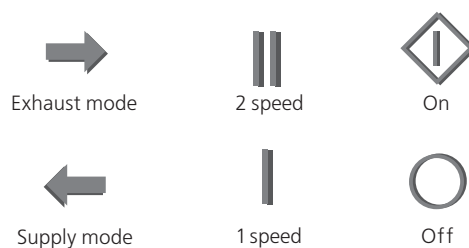

Fan on - louver shutters OPEN

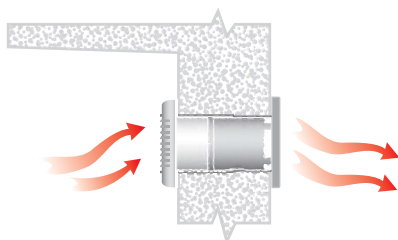

Fan operation in EXHAUST mode

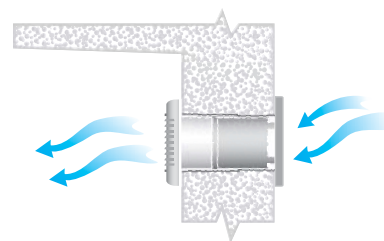

Fan operation in SUPPLY mode

### Accessories



Air ducts

Grilles and hoods

Clamps

### Aerodynamic characteristics

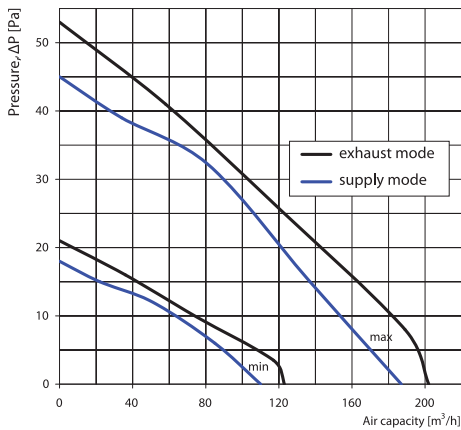

### Technical data

Model	Mode	Speed	Voltage [V] at 50 Hz	Power Consumption [W]	Current [A]	RPM [min <sup>-1</sup> ]	Maximum air capacity [m <sup>3</sup> /h]	Sound Pressure Level at 3 m [dB(A)]	Weight [kg]
VENTS 150 MA reverse	exhaust	max	220-240	8,7	0,045	1950	202	33	1,02
		min		5,2	0,025	1215	123	28	
	supply	max		7,6	0,045	2030	187	32	
		min		5,1	0,025	1210	110	26	

### Mounting set



### Mounting example



### Overall dimensions

Model	Dimensions [mm]						
	Ø D	B	B1	B2	H	L	L1
VENTS 150 MA reverse	150	212	196	150	195	114	33

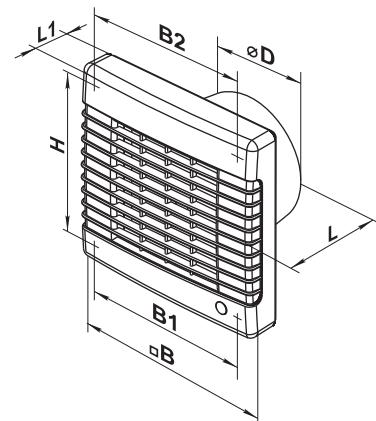

### Certificates



The fans meet the applicable safety and electromagnetic compatibility standards.



## VENTS X1 Series



Axial fans for exhaust ventilation with the capacity up to 345 m<sup>3</sup>/h

### Applications

- Continuous or periodic exhaust ventilation of bathroom, showers, kitchens and other utility spaces.
- Ventilation shaft mounting or duct connection.
- Low to medium air flow motion for short distances at low air resistance.
- Compatible with Ø 100, 125 and 150 mm air ducts.



### Design

- Modern design and aesthetic look.
- The casing and the impeller are made of high-quality durable ABS plastic, UV resistant.
- The intellectual impeller design makes the fan efficiency high and the service life long.
- Protection rating IP 24.

### Motor

- Reliable and low-watt electric motor.
- Designed for continuous operation and requires no maintenance.
- Equipped with overheating protection.

### Modifications and Options



**X1K** – fan is equipped with a backdraft damper for back flow preventing.



**X1L** – the motor is equipped with ball bearings for long service life (appr. 40 thousand hours) and fan mounting at any angle. The bearings are maintenance-free and contain enough grease for the entire operating period.



**X1 turbo** – high-powered motor.



**X112** – modification with low-voltage motor. 12 V AC power supply.



**X1T** – equipped with a regulated timer with the operating time from 2 to 30 minutes.



**X1TH** – equipped with a timer with the operating time from 2 to 30 minutes and a humidity sensor with the threshold value from 60 to 90%.



**X1V** – equipped with a pull cord switch.



**X1VT** – equipped with a pull cord switch and a regulated timer with the operating time adjustable from 2 to 30 minutes.



**X1VTH** – equipped with a pull cord switch, regulated timer with the operating time adjustable from 2 to 30 minutes and a humidity sensor with the operating threshold range from 60% to 90%.



**X1VTP** – equipped with a regulated timer and a motion sensor with the sensitivity area from 1 to 4 m and the detection angle up to 100°.

### Control

#### Manual:

- The fan is controlled by a room light switch. It is not included in the delivery package.
- The fan is controlled by the built-in pull cord switch **V**. Not applied in case of ceiling mounting.
- Speed control is possible through a thyristor speed controller (see Electrical Accessories). Several fans may be connected to the same regulator unit.

#### Automatic:

- By the electronic control unit **BU-1-60** (see Electrical Accessories). The control unit is supplied separately.
- By the timer **T** (the built-in run-out timer enables the fan operation within 2 to 30 minutes after the fan switching off).
- By the humidity sensor and timer **TH** (if the humidity level in the room exceeds the sensor threshold adjustable value within 60-90% the fan switches automatically on and operates until the humidity level drops to the standard level, after that the fan continues operating within the time period according to the timer setting, then shuts down).
- By the motion sensor and the timer **TP** (in case of motion detection the fan switches automatically on and operates within the set time period from 2 to 30 minutes. The motion sensitivity area is up to 4 meters and the maximum detection angle is 100°).

### Mounting features

- The fan is mounted directly into the ventilation shaft.
- Flexible duct application is recommended in case of remote location of the ventilation shaft. The air duct is connected to the fan exhaust flange through a clamp.
- Fixed to wall by self-tapping screws.
- Suitable for ceiling mounting.
- For 12 V low-voltage motor fan connection to 220 V / 50 Hz power mains use the step-down transformer TRF 220/12-25 that is available upon separate order.

### Accessories



### Aerodynamic characteristics

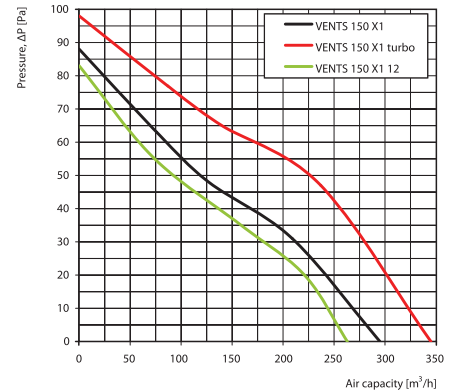
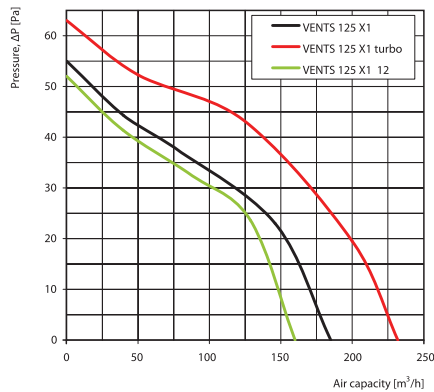
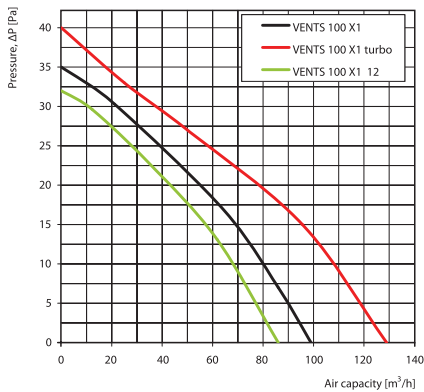

### Technical data

Model	Voltage [V] at 50 Hz	Power Consumption [W]	Current [A]	r.p.m.	Maximum air capacity [m³/h]	Sound Pressure Level at 3 m [dB(A)]	Weight [kg]
VENTS 100 X1	220-240	14	0,085	2300	99	33	0,60
VENTS 125 X1	220-240	16	0,1	2400	185	34	0,73
VENTS 150 X1	220-240	24	0,13	2400	295	37	0,92
VENTS 100 X1 turbo	220-240	16	0,1	2300	129	37	0,68
VENTS 125 X1 turbo	220-240	24	0,105	2400	232	37	0,80
VENTS 150 X1 turbo	220-240	30	0,13	2400	345	41	1,06
VENTS 100 X1 12	12	14	1,5	2200	86	33	0,59
VENTS 125 X1 12	12	16	1,7	2300	160	34	0,71
VENTS 150 X1 12	12	24	2	2300	263	36	0,88

### Mounting example



### Overall dimensions

Model	Dimensions [mm]				
	Ø D	B	H	L	L1
VENTS 100 X1	100	152	120	108	11,5
VENTS 125 X1	125	177	140	114	12,5
VENTS 150 X1	150	205	165	132	13

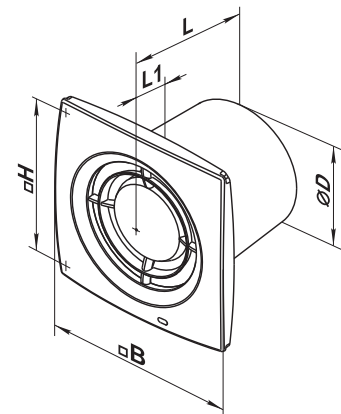

### Certificates



The fans meet the applicable safety and electromagnetic compatibility standards.

## VENTS F Series



Axial fans for exhaust ventilation with the capacity up to 232 m<sup>3</sup>/h

### Applications

- Continuous or periodic exhaust ventilation of bathroom, showers, kitchens and other utility spaces.
- Ventilation shaft mounting or duct connection.
- For rectangular ventilation shafts.
- Low to medium air flow motion for short distances at low air resistance.
- Compatible with Ø 100 and 125 mm air ducts.

### Design

- Modern design and aesthetic look.
- The casing and the impeller are made of high-quality durable ABS plastic, UV resistant.
- The intellectual impeller design makes the fan efficiency high and the service life long.
- The special front grille design enables natural ventilation of the premises without powering up the fan if required.
- Insect screen.
- Protection rating IP 34.
- Ventilation grille for natural air exhaust for application in premises with gas stoves.

### Motor

- Reliable and low-watt electric motor.
- Designed for continuous operation and requires no maintenance.
- Equipped with overheating protection.

### Modifications and Options



**FL** – the motor is equipped with ball bearings for long service life (appr. 40 thousand hours) and fan mounting at any angle. The bearings are maintenance-free and contain enough grease for the entire operating period.



**F turbo** – high-powered motor.



**F 12** – modification with low-voltage motor. 12 V AC power supply.

### Control

#### Manual:

- The fan is controlled by a room light switch. It is not included in the delivery package.
- Speed control is possible through a thyristor speed controller (see Electrical Accessories). Several fans may be connected to the same regulator unit.

#### Automatic:

- By the electronic control unit **BU-1-60** (see Electrical Accessories). The control unit is supplied separately.

### Mounting features

- The fan is mounted directly into the ventilation shaft.
- Flexible duct application is recommended in case of remote location of the ventilation shaft. The air duct is connected to the fan exhaust flange through a clamp.
- Fixed to wall by self-tapping screws.
- For 12 V low-voltage motor fan connection to 220 V / 50 Hz power mains use the step-down transformer TRF 220/12-25 that is available upon separate order.

### Accessories



### Aerodynamic characteristics

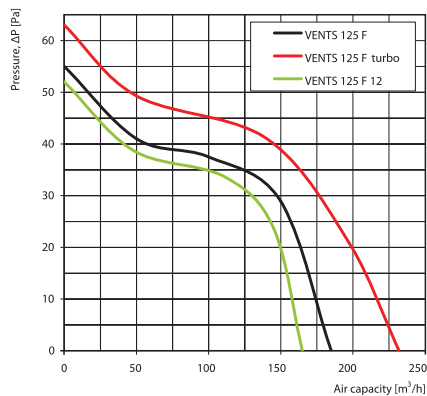
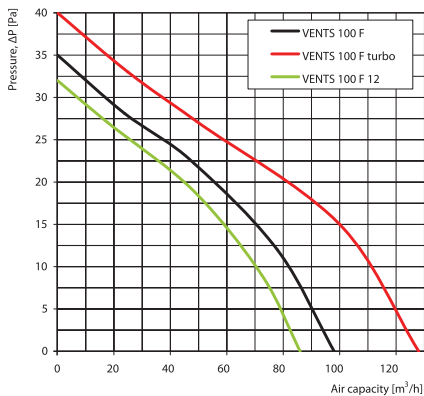

### Technical data

Model	Voltage [V] at 50 Hz	Power Consumption [W]	Current [A]	r.p.m.	Maximum air capacity [m³/h]	Sound Pressure Level at 3 m [dB(A)]	Weight [kg]
VENTS 100 F	220-240	14	0,085	2300	98	34	0,64
VENTS 125 F	220-240	16	0,1	2400	185	35	0,70
VENTS 100 F turbo	220-240	16	0,1	2300	128	37	0,72
VENTS 125 F turbo	220-240	24	0,1	2400	232	37	0,77
VENTS 100 F 12	12	14	1,5	2200	86	33	0,63
VENTS 125 F 12	12	16	1,7	2300	165	34	0,68

### Mounting example



### Overall dimensions

Model	Dimensions [mm]							
	Ø D	B	B1	B2	H	H1	L	L1
VENTS 100 F	100	182	152	160	252	226	104	13
VENTS 125 F	125	182	152	160	252	226	110	15

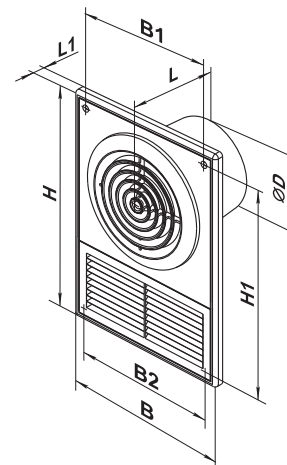

### Certificates



The fans meet the applicable safety and electromagnetic compatibility standards.

## VENTS F1 Series



Axial fans for exhaust ventilation with the capacity up to 232 m<sup>3</sup>/h

### Applications

- Continuous or periodic exhaust ventilation of bathroom, showers, kitchens and other utility spaces.
- Ventilation shaft mounting or duct connection.
- Designed for non-standard ventilation shafts with a large cross section.
- Low to medium air flow motion for short distances at low air resistance.
- Compatible with Ø 100 and 125 mm air ducts.

### Design

- Modern design and aesthetic look.
- The casing and the impeller are made of high-quality durable ABS plastic, UV resistant.
- The intellectual impeller design makes the fan efficiency high and the service life long.
- The special front grille design enables natural ventilation of the premises without powering up the fan if required.
- The enlarged front grille is specifically designed to fit non-standard ventilation shafts.
- Insect screen.
- Protection rating IP 34.
- Ventilation grille for natural air exhaust for application in premises with gas stoves.

### Motor

- Reliable and low-watt electric motor.
- Designed for continuous operation and requires no maintenance.
- Equipped with overheating protection.

### Modifications and Options



**F1 L** – the motor is equipped with ball bearings for long service life (appr. 40 thousand hours) and fan mounting at any angle. The bearings are maintenance-free and contain enough grease for the entire operating period.



**F1 turbo** – high-powered motor.



**F1 12** – modification with low-voltage motor. 12 V AC power supply.



**FIT** – equipped with a regulated timer with the operating time from 2 to 30 minutes.

### Control

#### Manual:

- The fan is controlled by a room light switch. It is not included in the delivery package.
- Speed control is possible through a thyristor speed controller (see Electrical Accessories). Several fans may be connected to the same regulator unit.

#### Automatic:

- By the electronic control unit **BU-1-60** (see Electrical Accessories). The control unit is supplied separately.
- By the timer **T** (the built-in run-out timer enables the fan operation within 2 to 30 minutes after the fan switching off).

### Mounting features

- The fan is mounted directly into the ventilation shaft.
- Flexible duct application is recommended in case of remote location of the ventilation shaft. The air duct is connected to the fan exhaust flange through a clamp.
- Fixed to wall by self-tapping screws.
- For 12 V low-voltage motor fan connection to 220 V / 50 Hz power mains use the step-down transformer TRF 220/12-25 that is available upon separate order.

### Accessories



Air ducts

Grilles and hoods

Backdraft damper

Speed controllers

Clamps

### Aerodynamic characteristics

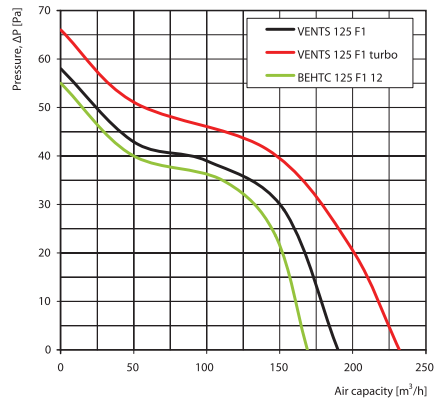
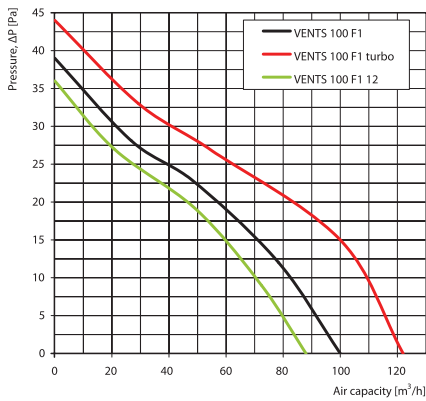

### Technical data

Model	Voltage [V] at 50 Hz	Power Consumption [W]	Current [A]	r.p.m.	Maximum air capacity [m³/h]	Sound Pressure Level at 3 m [dB(A)]	Weight [kg]
VENTS 100 F1	220-240	14	0,085	2300	100	33	0,58
VENTS 125 F1	220-240	16	0,1	2400	190	35	0,80
VENTS 100 F1 turbo	220-240	16	0,1	2300	122	36	0,68
VENTS 125 F1 turbo	220-240	24	0,105	2400	232	37	0,85
VENTS 100 F1 12	12	14	1,5	2200	88	32	0,58
VENTS 125 F1 12	12	16	1,7	2300	169	34	0,80

### Mounting example



### Overall dimensions

Model	Dimensions [mm]							
	Ø D	B	B1	B2	H	H1	L	L1
VENTS 100 F1	100	182	152	160	252	226	128	13
VENTS 125 F1	125	182	152	160	252	226	134	15

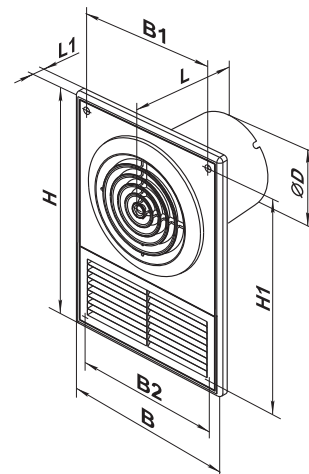

### Certificates



The fans meet the applicable safety and electromagnetic compatibility standards.

## VENTS K Series



Axial fans for exhaust ventilation with the capacity up to 341 m<sup>3</sup>/h

### Applications

- Continuous or periodic exhaust ventilation of bathroom, showers, kitchens and other utility spaces.
- Ventilation shaft mounting or duct connection.
- Low to medium air flow motion for short distances at low air resistance.
- Compatible with Ø 100, 125 and 150 mm air ducts.

### Design

- Classic design and aesthetic look.
- The casing and the impeller are made of high-quality durable ABS plastic, UV resistant.
- The intellectual impeller design makes the fan efficiency high and the service life long.
- Insect screen.
- Protection rating IP 34.

### Motor

- Reliable and low-watt electric motor.
- Designed for continuous operation and requires no maintenance.
- Equipped with overheating protection.

### Modifications and Options



**K L** – the motor is equipped with ball bearings for long service life (appr. 40 thousand hours) and fan mounting at any angle. The bearings are maintenance-free and contain enough grease for the entire operating period.



**K turbo** – high-powered motor.



**K 12** – modification with low-voltage motor. 12 V AC power supply.

### Control

#### Manual:

- The fan is controlled by a room light switch. It is not included in the delivery package.
- Speed control is possible through a thyristor speed controller (see Electrical Accessories). Several fans may be connected to the same regulator unit.

#### Automatic:

- By the electronic control unit **BU-1-60** (see Electrical Accessories). The control unit is supplied separately.

### Mounting features

- The fan is mounted directly into the ventilation shaft.
- Flexible duct application is recommended in case of remote location of the ventilation shaft. The air duct is connected to the fan exhaust flange through a clamp.
- Fixed to wall by self-tapping screws.
- Suitable for ceiling mounting.
- For 12 V low-voltage motor fan connection to 220 V / 50 Hz power mains use the step-down transformer TRF 220/12-25 that is available upon separate order.

### Accessories



Air ducts

Grilles and hoods

Backdraft damper

Speed controllers

Clamps

### Aerodynamic characteristics

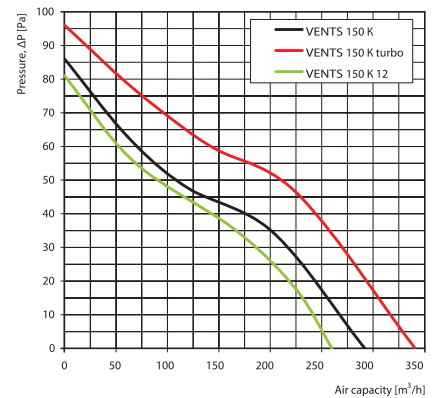
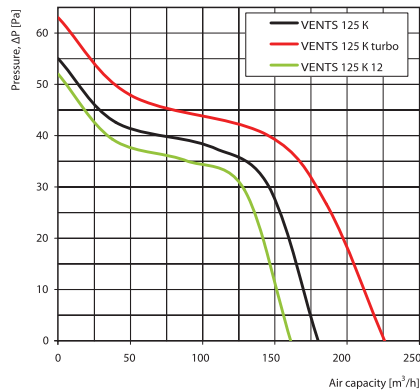
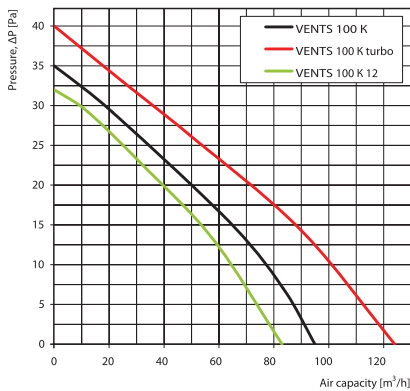

### Technical data

Model	Voltage [V] at 50 Hz	Power Consumption [W]	Current [A]	r.p.m.	Maximum air capacity [m <sup>3</sup> /h]	Sound Pressure Level at 3 m [dB(A)]	Weight [kg]
VENTS 100 K	220-240	14	0,085	2300	95	34	0,53
VENTS 125 K	220-240	16	0,1	2400	180	35	0,65
VENTS 150 K	220-240	24	0,13	2400	292	38	1,07
VENTS 100 K turbo	220-240	16	0,1	2300	124	37	0,61
VENTS 125 K turbo	220-240	24	0,105	2400	226	37	0,72
VENTS 150 K turbo	220-240	30	0,13	2400	341	40	1,21
VENTS 100 K 12	12	14	1,5	2200	83	33	0,52
VENTS 125 K 12	12	16	1,7	2300	161	34	0,63
VENTS 150 K 12	12	24	2	2300	260	37	1,03

### Mounting example



### Overall dimensions

Model	Dimensions [mm]				
	Ø D	B	H	L	L1
VENTS 100 K	100	154	110	105	15
VENTS 125 K	125	187	142	112	15
VENTS 150 K	150	250	214	127	15

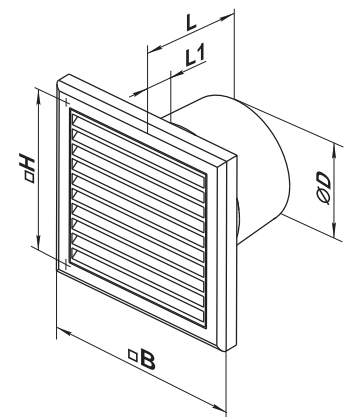

### Certificates



The fans meet the applicable safety and electromagnetic compatibility standards.



## VENTS K1 Series



Axial fans for exhaust ventilation with the capacity up to 226 m<sup>3</sup>/h

### Applications

- Continuous or periodic exhaust ventilation of bathroom, showers, kitchens and other utility spaces.
- Ventilation shaft mounting or duct connection.
- Low to medium air flow motion for short distances at low air resistance.
- Compatible with Ø 100 and 125 mm air ducts.

### Design

- Classic design and aesthetic look.
- The casing and the impeller are made of high-quality durable ABS plastic, UV resistant.
- The intellectual impeller design makes the fan efficiency high and the service life long.
- Insect screen.
- Protection rating IP 34.

### Motor

- Reliable and low-watt electric motor.
- Designed for continuous operation and requires no maintenance.
- Equipped with overheating protection.

### Modifications and Options



**K1 L** – The motor is equipped with ball bearings for long service life (appr. 40 thousand hours) and fan mounting at any angle. The bearings are maintenance-free and contain enough grease for the entire operating period.



**K1 turbo** – high-powered motor.



**K1 12** – modification with low-voltage motor. 12 V AC power supply.

### Control

#### Manual:

- The fan is controlled by a room light switch. It is not included in the delivery package.
- Speed control is possible through a thyristor speed controller (see Electrical Accessories). Several fans may be connected to the same regulator unit.

#### Automatic:

- By the electronic control unit **BU-1-60** (see Electrical Accessories). The control unit is supplied separately.

### Mounting features

- The fan is mounted directly into the ventilation shaft.
- Flexible duct application is recommended in case of remote location of the ventilation shaft. The air duct is connected to the fan exhaust flange through a clamp.
- Fixed to wall by self-tapping screws.
- Suitable for ceiling mounting.
- For 12 V low-voltage motor fan connection to 220 V / 50 Hz power mains use the step-down transformer TRF 220/12-25 that is available upon separate order.

### Accessories



Air ducts

Grilles and hoods

Backdraft damper

Speed controllers

Clamps

### Aerodynamic characteristics

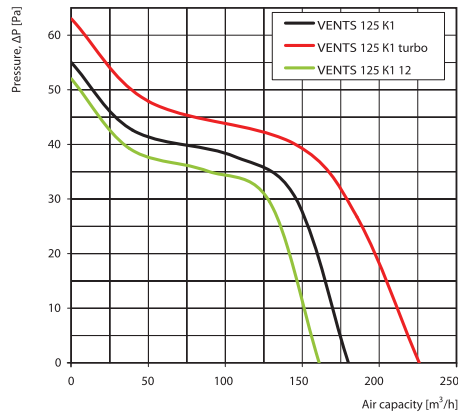
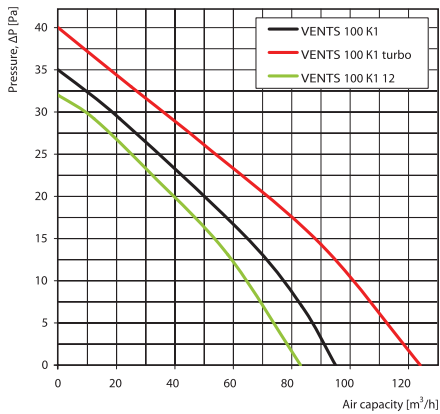

### Technical data

Model	Voltage [V] at 50 Hz	Power Consumption [W]	Current [A]	r.p.m.	Maximum air capacity [m³/h]	Sound Pressure Level at 3 m [dB(A)]	Weight [kg]
VENTS 100 K1	220-240	14	0,085	2300	95	34	0,52
VENTS 125 K1	220-240	16	0,1	2400	180	35	0,70
VENTS 100 K1 turbo	220-240	16	0,1	2300	124	37	0,60
VENTS 125 K1 turbo	220-240	24	0,105	2400	226	37	0,77
VENTS 100 K1 12	12	14	1,5	2200	83	33	0,50
VENTS 125 K1 12	12	16	1,7	2300	161	34	0,66

### Mounting example



### Overall dimensions

Model	Dimensions [mm]				
	∅ D	B	H	L	L1
VENTS 100 K1	100	154	110	108,5	18,5
VENTS 125 K1	125	187	142	116	19

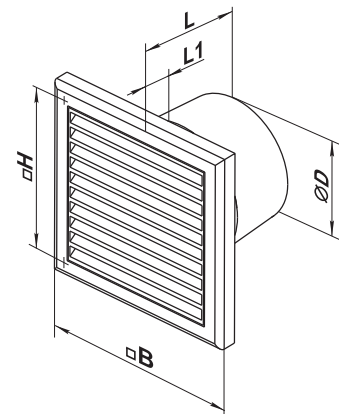

### Certificates



The fans meet the applicable safety and electromagnetic compatibility standards.

## VENTS PF Series



Axial fans for exhaust ventilation with the capacity up to 342 m<sup>3</sup>/h

### Applications

- Continuous or periodic exhaust ventilation of bathroom, showers, kitchens and other utility spaces.
- Ventilation shaft mounting or duct connection.
- Low to medium air flow motion for short distances at low air resistance.
- Compatible with Ø 100, 125 and 150 mm air ducts.

### Design

- Modern design and aesthetic look.
- The casing and the impeller are made of high-quality durable ABS plastic, UV resistant.
- The intellectual impeller design makes the fan efficiency high and the service life long.
- Insect screen.
- Protection rating IP 34.

### Motor

- Reliable and low-watt electric motor.
- Designed for continuous operation and requires no maintenance.
- Equipped with overheating protection.

### Modifications and Options



**PF L** – the motor is equipped with ball bearings for long service life (appr. 40 thousand hours) and fan mounting at any angle. The bearings are maintenance-free and contain enough grease for the entire operating period.



**PF turbo** – high-powered motor.



**PF press** – 5-blade low-noise impeller with improved aerodynamics for higher fan capacity.



**PF 12** – modification with low-voltage motor. 12 V AC power supply.

### Control

#### Manual:

- The fan is controlled by a room light switch. It is not included in the delivery package.
- Speed control is possible through a thyristor speed controller (see Electrical Accessories). Several fans may be connected to the same regulator unit.

#### Automatic:

- By the electronic control unit **BU-1-60** (see Electrical Accessories). The control unit is supplied separately.

### Mounting features

- The fan is mounted directly into the ventilation shaft.
- Flexible duct application is recommended in case of remote location of the ventilation shaft. The air duct is connected to the fan exhaust flange through a clamp.
- Fixed to wall by self-tapping screws.
- Suitable for ceiling mounting.
- For 12 V low-voltage motor fan connection to 220 V / 50 Hz power mains use the step-down transformer TRF 220/12-25 that is available upon separate order.

### Accessories



Air ducts

Grilles and hoods

Backdraft damper

Speed controllers

Clamps

### Aerodynamic characteristics

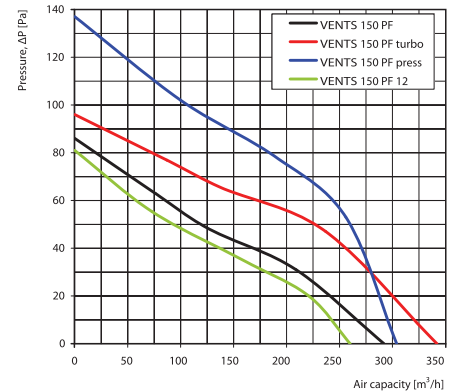
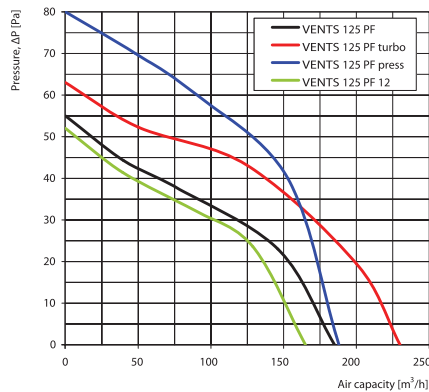
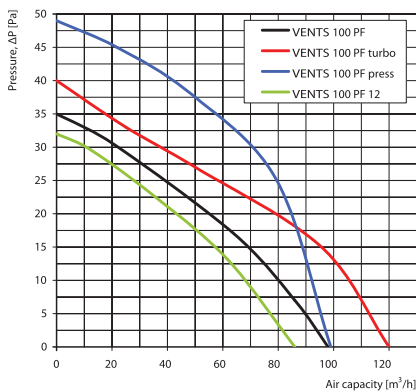

### Technical data

Model	Voltage [V] at 50 Hz	Power Consumption [W]	Current [A]	r.p.m.	Maximum air capacity [m³/h]	Sound Pressure Level at 3 m [dB(A)]	Weight [kg]
VENTS 100 PF	220-240	14	0,085	2300	98	34	0,47
VENTS 125 PF	220-240	16	0,1	2400	185	35	0,58
VENTS 150 PF	220-240	24	0,13	2400	292	38	0,90
VENTS 100 PF turbo	220-240	16	0,1	2300	120	40	0,52
VENTS 125 PF turbo	220-240	24	0,1	2400	230	42	0,60
VENTS 150 PF turbo	220-240	30	0,13	2400	342	42	1,02
VENTS 100 PF press	220-240	16	0,1	2300	99	38	0,47
VENTS 125 PF press	220-240	24	0,105	2400	188	39	0,58
VENTS 150 PF press	220-240	30	0,13	2400	304	40	0,90
VENTS 100 PF 12	12	14	1,5	2200	86	33	0,46
VENTS 125 PF 12	12	16	1,7	2300	165	34	0,56
VENTS 150 PF 12	12	24	2	2300	260	37	0,74

### Mounting example



### Overall dimensions

Model	Dimensions [mm]			
	Ø D	Ø D1	L	L1
VENTS 100 PF	100	141	104	13
VENTS 125 PF	125	166	110	15
VENTS 150 PF	150	188	125	15

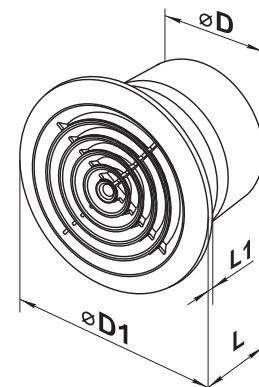

### Certificates



The fans meet the applicable safety and electromagnetic compatibility standards.

## VENTS PF1 Series



Axial fans for exhaust ventilation with the capacity up to 349 m<sup>3</sup>/h

### Applications

- Continuous or periodic exhaust ventilation of bathroom, showers, kitchens and other utility spaces.
- Ventilation shaft mounting or duct connection.
- Low to medium air flow motion for short distances at low air resistance.
- Compatible with Ø 100, 125 and 150 mm air ducts.

### Design

- Modern design and aesthetic look.
- The casing and the impeller are made of high-quality durable ABS plastic, UV resistant.
- The intellectual impeller design makes the fan efficiency high and the service life long.
- Insect screen.
- Protection rating IP 34.

### Motor

- Reliable and low-watt electric motor.
- Designed for continuous operation and requires no maintenance.
- Equipped with overheating protection.

### Modifications and Options



**PF1L** – The motor is equipped with ball bearings for long service life (appr. 40 thousand hours) and fan mounting at any angle. The bearings are maintenance-free and contain enough grease for the entire operating period.



**PF1 turbo** – high-powered motor.



**PF1 press** – 5-blade low-noise impeller with improved aerodynamics for higher fan capacity.



**PF1 12** – modification with low-voltage motor. 12 V AC power supply.



**PF1T** – equipped with a regulated timer with the operating time from 2 to 30 minutes.

### Control

#### Manual:

- The fan is controlled by a room light switch. It is not included in the delivery package.
- Speed control is possible through a thyristor speed controller (see Electrical Accessories). Several fans may be connected to the same regulator unit.

#### Automatic:

- By the electronic control unit **BU-1-60** (see Electrical Accessories). The control unit is supplied separately.
- By the timer **T** (the built-in run-out timer enables the fan operation within 2 to 30 minutes after the fan switching off).

### Mounting features

- The fan is mounted directly into the ventilation shaft.
- Flexible duct application is recommended in case of remote location of the ventilation shaft. The air duct is connected to the fan exhaust flange through a clamp.
- Fixed to wall by self-tapping screws.
- Suitable for ceiling mounting.
- For 12 V low-voltage motor fan connection to 220 V / 50 Hz power mains use the step-down transformer TRF 220/12-25 that is available upon separate order.

### Accessories



Air ducts

Grilles and hoods

Backdraft damper

Speed controllers

Clamps

## Aerodynamic characteristics

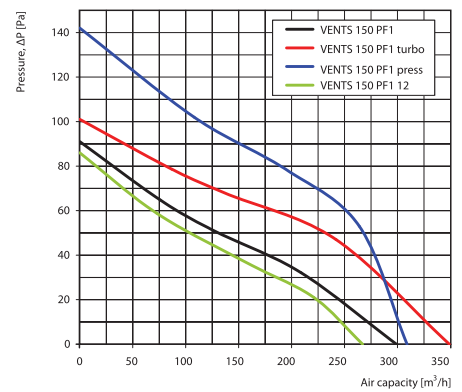
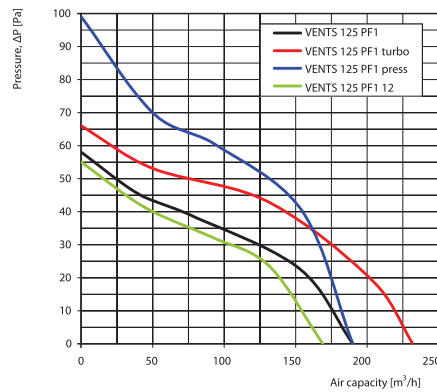
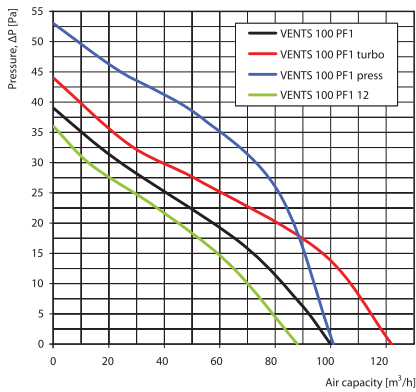

## Technical data

Model	Voltage [V] at 50 Hz	Power Consumption [W]	Current [A]	r.p.m.	Maximum air capacity [m³/h]	Sound Pressure Level at 3 m [dB(A)]	Weight [kg]
VENTS 100 PF1	220-240	14	0,085	2300	100	33	0,47
VENTS 125 PF1	220-240	16	0,1	2400	190	35	0,70
VENTS 150 PF1	220-240	24	0,13	2400	299	38	0,84
VENTS 100 PF1 turbo	220-240	16	0,1	2300	122	39	0,58
VENTS 125 PF1 turbo	220-240	24	0,105	2400	232	42	0,75
VENTS 150 PF1 turbo	220-240	30	0,13	2400	349	40	0,98
VENTS 100 PF1 press	220-240	16	0,1	2300	101	38	0,47
VENTS 125 PF1 press	220-240	24	0,105	2400	190	39	0,70
VENTS 150 PF1 press	220-240	30	0,13	2400	309	38	0,84
VENTS 100 PF1 12	12	14	1,5	2300	88	32	0,47
VENTS 125 PF1 12	12	16	1,7	2400	169	34	0,70
VENTS 150 PF1 12	12	24	2	2400	267	37	0,84

## Mounting example



## Overall dimensions

Model	Dimensions [mm]			
	Ø D	Ø D1	L	L1
VENTS 100 PF1	100	141	128	13
VENTS 125 PF1	125	166	134	15
VENTS 150 PF1	150	188	146	15

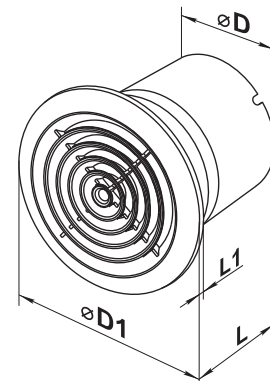

## Certificates



The fans meet the applicable safety and electromagnetic compatibility standards.

## VENTS S Series



Axial fans for exhaust ventilation with the capacity up to 341 m<sup>3</sup>/h

### Applications

- Continuous or periodic exhaust ventilation of bathroom, showers, kitchens and other utility spaces.
- Ventilation shaft mounting or duct connection.
- Low to medium air flow motion for short distances at low air resistance.
- Compatible with Ø 100, 125 and 150 mm air ducts.



### Design

- Modern design and aesthetic look.
- The casing and the impeller are made of high-quality durable ABS plastic, UV resistant.
- The intellectual impeller design makes the fan efficiency high and the service life long.
- Ultra thin front panel.
- Insect screen.
- Protection rating IP 34.

### Motor

- Reliable and low-watt electric motor.
- Designed for continuous operation and requires no maintenance.
- Equipped with overheating protection.

### Modifications and Options

**S1** – shortened flange model.



**SK** – fan is equipped with a backdraft damper for back flow preventing.



**SL** – the motor is equipped with ball bearings for long service life (appr. 40 thousand hours) and fan mounting at any angle. The bearings are maintenance-free and contain enough grease for the entire operating period.



**S turbo** – high-powered motor.



**S 12** – modification with low-voltage motor. 12 V AC power supply.



**ST** – equipped with a regulated timer with the operating time from 2 to 30 minutes.



**STH** – equipped with a timer with the operating time from 2 to 30 minutes and a humidity sensor with the threshold value from 60 to 90%.



**SV** – equipped with a pull cord switch.



**SVT** – equipped with a pull cord switch and a regulated timer with the operating time adjustable from 2 to 30 minutes.



**SVTH** – equipped with a pull cord switch, regulated timer with the operating time adjustable from 2 to 30 minutes and a humidity sensor with the operating threshold range from 60% to 90%.

### Control

#### Manual:

- The fan is controlled by a room light switch. It is not included in the delivery package.
- The fan is controlled by the built-in pull cord switch **V**. Not applied in case of ceiling mounting.
- Speed control is possible through a thyristor speed controller (see Electrical Accessories). Several fans may be connected to the same regulator unit.

#### Automatic:

- By the electronic control unit **BU-1-60** (see Electrical Accessories). The control unit is supplied separately.
- By the timer **T** (the built-in run-out timer enables the fan operation within 2 to 30 minutes after the fan switching off).
- By the humidity sensor and timer **TH** (if the humidity level in the room exceeds the sensor threshold adjustable value within 60-90% the fan switches automatically on and operates until the humidity level drops to the standard level, after that the fan continues operating within the time period according to the timer setting, then shuts down).

### Mounting features

- The fan is mounted directly into the ventilation shaft.
- Flexible duct application is recommended in case of remote location of the ventilation shaft. The air duct is connected to the fan exhaust flange through a clamp.
- Fixed to wall by self-tapping screws.
- Suitable for ceiling mounting.
- For 12 V low-voltage motor fan connection to 220 V / 50 Hz power mains use the step-down transformer TRF 220/12-25 that is available upon separate order.

### Accessories



### Aerodynamic characteristics

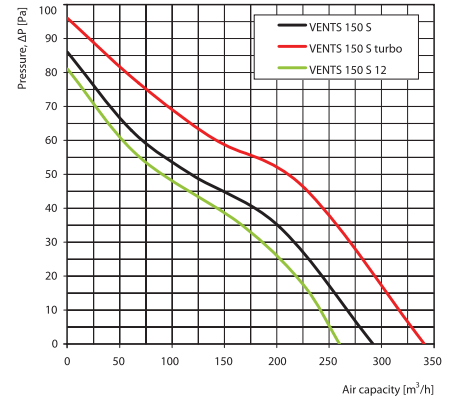
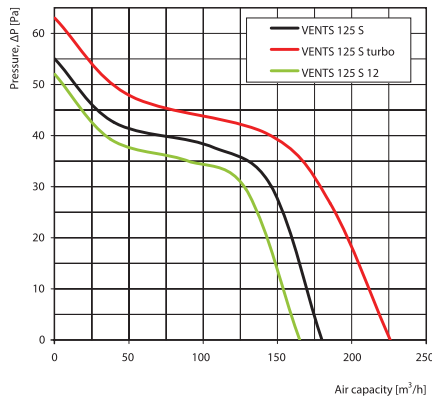
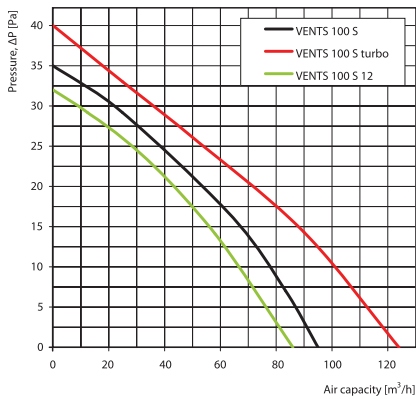

### Technical data

Model	Voltage [V] at 50 Hz	Power Consumption [W]	Current [A]	r.p.m.	Maximum air capacity [m³/h]	Sound Pressure Level at 3 m [dB(A)]	Weight [kg]
VENTS 100 S	220-240	14	0,085	2300	95	34	0,59
VENTS 125 S	220-240	16	0,1	2400	180	35	0,75
VENTS 150 S	220-240	24	0,13	2400	292	38	0,93
VENTS 100 S turbo	220-240	16	0,1	2300	124	37	0,67
VENTS 125 S turbo	220-240	24	0,105	2400	226	37	0,82
VENTS 150 S turbo	220-240	30	0,13	2400	341	40	1,07
VENTS 100 S 12	12	14	1,5	2200	86	33	0,58
VENTS 125 S 12	12	16	1,7	2300	165	34	0,73
VENTS 150 S 12	12	24	2	2300	260	37	0,89

### Mounting example



### Overall dimensions

Model	Dimensions [mm]				
	Ø D	B	H	L	L1
VENTS 100 S	100	150	120	108	12
VENTS 100 S1	100	150	120	93	12
VENTS 125 S	125	176	140	114	13
VENTS 125 S1	125	176	140	96	13
VENTS 150 S	150	205	165	132	14

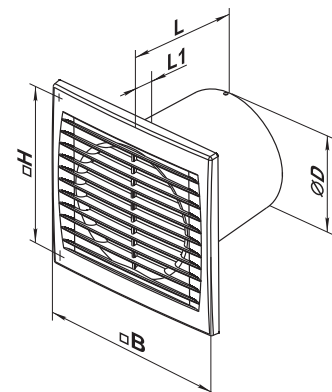

### Certificates



The fans meet the applicable safety and electromagnetic compatibility standards.



## VENTS D Series



Axial fans for exhaust ventilation with the capacity up to 341 m<sup>3</sup>/h

### Applications

- Continuous or periodic exhaust ventilation of bathroom, showers, kitchens and other utility spaces.
- Ventilation shaft mounting or duct connection.
- Low to medium air flow motion for short distances at low air resistance.
- Compatible with Ø 100, 125 and 150 mm air ducts.



### Design

- Ultra slim front panel - only 6,5 mm.
- Modern design and aesthetic look.
- The casing and the impeller are made of high-quality durable ABS plastic, UV resistant.
- The intellectual impeller design makes the fan efficiency high and the service life long.
- Insect screen.
- Protection rating IP 34.

### Motor

- Reliable and low-watt electric motor.
- Designed for continuous operation and requires no maintenance.
- Equipped with overheating protection.

### Modifications and Options

**D1** – Shortened flange model.



**DK** – fan is equipped with a backdraft damper for back flow preventing.



**DL** – the motor is equipped with ball bearings for long service life (appr. 40 thousand hours) and fan mounting at any angle. The bearings are maintenance-free and contain enough grease for the entire operating period.



**D turbo** – high-powered motor.



**D 12** – modification with low-voltage motor. 12 V AC power supply.



**DT** – equipped with a regulated timer with the operating time from 2 to 30 minutes.



**DTH** – equipped with a timer with the operating time from 2 to 30 minutes and a humidity sensor with the threshold value from 60 to 90%.



**DV** – equipped with a pull cord switch.



**DVT** – equipped with a pull cord switch and a regulated timer with the operating time adjustable from 2 to 30 minutes.



**DVTH** – equipped with a pull cord switch, regulated timer with the operating time adjustable from 2 to 30 minutes and a humidity sensor with the operating threshold range from 60% to 90%.

### Control

#### Manual:

- The fan is controlled by a room light switch. It is not included in the delivery package.
- The fan is controlled by the built-in pull cord switch **V**. Not applied in case of ceiling mounting.

- Speed control is possible through a thyristor speed controller (see Electrical Accessories). Several fans may be connected to the same regulator unit.

#### Automatic:

- By the electronic control unit **BU-1-60** (see Electrical Accessories). The control unit is supplied separately.

- By the timer **T** (the built-in run-out timer enables the fan operation within 2 to 30 minutes after the fan switching off).

- By the humidity sensor and timer **TH** (if the humidity level in the room exceeds the sensor threshold adjustable value within 60-90% the fan switches automatically on and operates until the humidity level drops to the standard level, after that the fan continues operating within the time period according to the timer setting, then shuts down).

### Mounting features

- The fan is mounted directly into the ventilation shaft.
- Flexible duct application is recommended in case of remote location of the ventilation shaft. The air duct is connected to the fan exhaust flange through a clamp.
- Fixed to wall by self-tapping screws.
- Suitable for ceiling mounting.
- For 12 V low-voltage motor fan connection to 220 V / 50 Hz power mains use the step-down transformer TRF 220/12-25 that is available upon separate order.

### Accessories



Air ducts

Grilles and hoods

Backdraft damper

Speed controllers

Clamps

### Aerodynamic characteristics

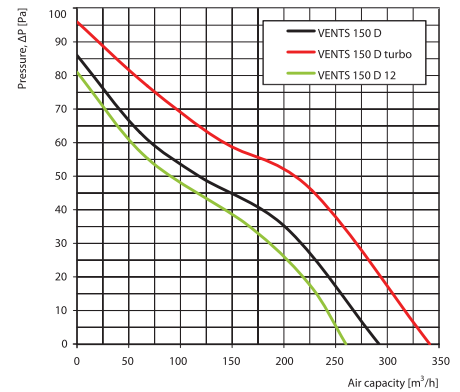
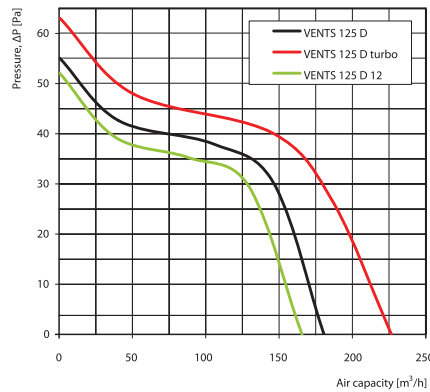
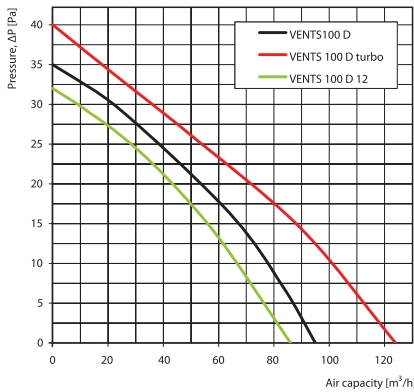

### Technical data

Model	Voltage [V] at 50 Hz	Power Consumption [W]	Current [A]	r.p.m.	Maximum air capacity [m³/h]	Sound Pressure Level at 3 m [dB(A)]	Weight [kg]
VENTS 100 D	220-240	14	0,085	2300	95	34	0,58
VENTS 125 D	220-240	16	0,1	2400	180	35	0,74
VENTS 150 D	220-240	24	0,13	2400	292	38	0,92
VENTS 100 D turbo	220-240	16	0,1	2300	124	37	0,66
VENTS 125 D turbo	220-240	24	0,105	2400	226	37	0,81
VENTS 150 D turbo	220-240	30	0,13	2400	341	40	1,06
VENTS 100 D 12	12	14	1,5	2200	86	33	0,60
VENTS 125 D 12	12	16	1,7	2300	165	34	0,69
VENTS 150 D 12	12	24	2	2300	260	37	0,88

### Mounting example



### Overall dimensions

Model	Dimensions [mm]				
	Ø D	B	H	L	L1
VENTS 100 D	100	150	120	108,5	12,5
VENTS 100 D1	100	150	120	93	12,5
VENTS 125 D	125	176	140	114	12,5
VENTS 125 D1	125	176	140	96	12,5
VENTS 150 D	150	205	165	132	13

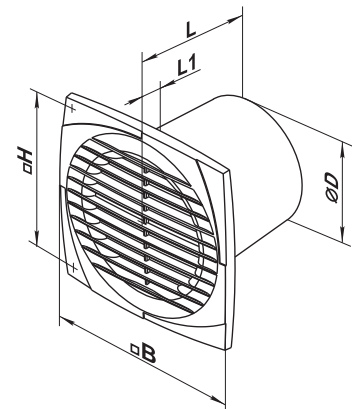

### Certificates



The fans meet the applicable safety and electromagnetic compatibility standards.

# AXIAL DECORATIVE FANS

## ▶ VENTS LD, VENTS LD Auto and VENTS LD light Series



Axial fans with a thin front panel for exhaust ventilation with the capacity up to 345 m<sup>3</sup>/h. Different color modifications of the front panel. Compatible with Ø 100, 125 and 150 mm air ducts.

## ▶ VENTS LD Fresh Time Series



Axial fans with a built-in clock for exhaust ventilation with the capacity up to 115 m<sup>3</sup>/h. Compatible with Ø 100 mm air ducts.

## ▶ VENTS Modern and VENTS Modern Auto Series



Axial fans with a thin front panel for exhaust ventilation with the capacity up to 345 m<sup>3</sup>/h. Compatible with Ø 100, 125 and 150 mm air ducts.

## ▶ VENTS Z and VENTS Z Star Series



Axial fans with a stainless steel front panel for exhaust ventilation with the capacity up to 358 m<sup>3</sup>/h. Different types of drawings of the front panel. VENTS Z Star Series fans are equipped with a built-in LED lighting. Compatible with Ø 100, 125 and 150 mm air ducts.

## ▶ VENTS Vitro and VENTS Vitro Star Series











Axial fans with a glass front panel for exhaust ventilation with the capacity up to 358 m<sup>3</sup>/h. Different types of drawings of the front panel. VENTS Vitro Star Series fans are equipped with a built-in LED lighting. Compatible with Ø 100, 125 and 150 mm air ducts.

## ▶ VENTS X and VENTS X Star Series



Axial fans for exhaust ventilation with the capacity up to 302 m<sup>3</sup>/h. VENTS X star series fans are equipped with a built-in LED lighting. Compatible with Ø 100, 125 and 150 mm air ducts.

	<p><b>Axial decorative fans</b>  <b>VENTS LD, VENTS LD Auto, VENTS LD light Series</b></p>	<p>page 68</p>
	<p><b>Axial decorative fans</b>  <b>VENTS LD Fresh Time Series</b></p>	<p>page 74</p>
	<p><b>Axial decorative fans</b>  <b>VENTS Modern, VENTS Modern Auto Series</b></p>	<p>page 76</p>
	<p><b>Axial decorative fans</b>  <b>VENTS Domino Series</b></p>	<p>page 80</p>
	<p><b>Axial decorative fans</b>  <b>VENTS Z Series</b></p>	<p>page 82</p>
	<p><b>Axial decorative fans</b>  <b>VENTS Z Star Series</b></p>	<p>page 84</p>
	<p><b>Axial decorative fans</b>  <b>VENTS Vitro Series</b></p>	<p>page 86</p>
	<p><b>Axial decorative fans</b>  <b>VENTS Vitro Star Series</b></p>	<p>page 88</p>
	<p><b>Axial decorative fans</b>  <b>VENTS X Series</b></p>	<p>page 90</p>
	<p><b>Axial decorative fans</b>  <b>VENTS X Star Series</b></p>	<p>page 92</p>

## VENTS LD Series



Axial decorative fans for exhaust ventilation with the capacity up to 310 m<sup>3</sup>/h

### Applications

- Continuous or periodic exhaust ventilation of bathroom, showers, kitchens and other utility spaces.
- Ventilation shaft mounting or duct connection.
- Low to medium air flow motion for short distances at low air resistance.
- Compatible with Ø 100, 125 and 150 mm air ducts.



### Design

- Modern design and aesthetic look.
- The casing and the impeller are made of high-quality durable ABS plastic, UV resistant.
- Various decorative plates for the front panel of the natural aluminium.
- The intellectual impeller design makes the fan efficiency high and the service life long.
- Protection rating IP 34.

### Motor

- Reliable and low-watt electric motor.
- Designed for continuous operation and requires no maintenance.
- Equipped with overheating protection.

### Modifications and Options

**LDN** – the fan with a polished stainless steel front panel.

**LDA** – the fan with a ground aluminium front panel.

**LDA Gold** – the fan with a gold-tinted aluminium front panel.

**LDA Chrome** – the fan with a mirror finish aluminium front panel.

**LD alumat** – fan with a matt gray painted front plate.

**LD1** – shortened branch pipe model.

 **LD K** – fan is equipped with a backdraft damper for back flow preventing.

 **LD L** – the motor is equipped with ball bearings for long service life (appr. 40 thousand hours) and fan mounting at any angle. The bearings are maintenance-free and contain enough grease for the entire operating period.



 **LD turbo** – high-powered motor.

 **LD 12** – modification with low-voltage motor. 12 V AC power supply.

 **LDT** – equipped with a regulated timer with the operating time from 2 to 30 minutes.

 **LDTH** – equipped with a timer with the operating time from 2 to 30 minutes and a humidity sensor with the threshold value from 60 to 90%.

 **LDV** – equipped with a pull cord switch.

  **LDVT** – equipped with a pull cord switch and a regulated timer with the operating time adjustable from 2 to 30 minutes.

   **LDVTH** – equipped with a pull cord switch, regulated timer with the operating time adjustable from 2 to 30 minutes and a humidity sensor with the operating threshold range from 60% to 90%.

### Control

#### Manual:

- The fan is controlled by a room light switch. It is not included in the delivery package.
- The fan is controlled by the built-in pull cord switch **V**. Not applied in case of ceiling mounting.
- Speed control is possible through a thyristor speed controller (see Electrical Accessories). Several fans may be connected to the same regulator unit.

#### Automatic:

- By the electronic control unit **BU-1-60** (see Electrical Accessories). The control unit is supplied separately.
- By the timer **T** (the built-in run-out timer enables the fan operation within 2 to 30 minutes after the fan switching off).
- By the humidity sensor and timer **TH** (if the humidity level in the room exceeds the sensor threshold adjustable value within 60-90% the fan switches automatically on and operates until the humidity level drops to the standard level, after that the fan continues operating within the time period according to the timer setting, then shuts down).

### Mounting features

- The fan is mounted directly into the ventilation shaft.
- Flexible duct application is recommended in case of remote location of the ventilation shaft. The air duct is connected to the fan exhaust flange through a clamp.
- Fixed to wall by self-tapping screws.
- Suitable for ceiling mounting.
- For 12 V low-voltage motor fan connection to 220 V / 50 Hz power mains use the step-down transformer TRF 220/12-25 that is available upon separate order.

### Accessories



### Aerodynamic characteristics

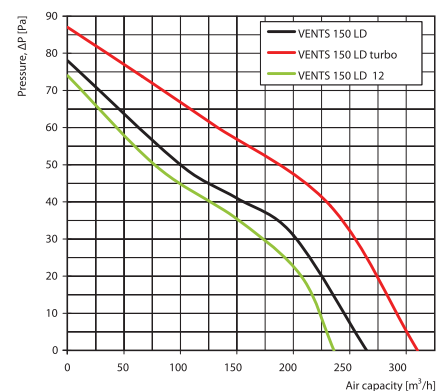
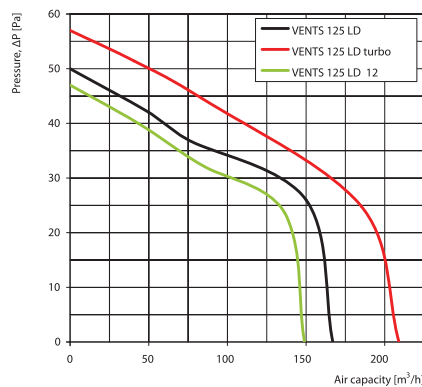
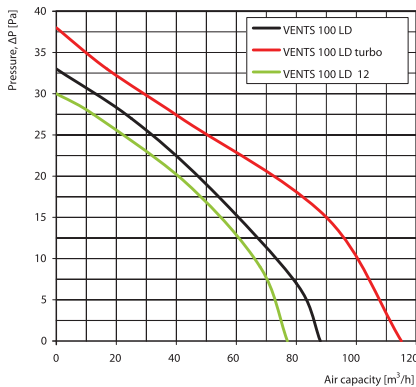

### Technical data

Model	Voltage [V] at 50 Hz	Power Consumption [W]	Current [A]	r.p.m.	Maximum air capacity [m³/h]	Sound Pressure Level at 3 m [dB(A)]	Weight [kg]
VENTS 100 LD	220-240	14	0,085	2300	88	33	0,60
VENTS 125 LD	220-240	16	0,1	2400	167	34	0,74
VENTS 150 LD	220-240	24	0,13	2400	265	37	0,96
VENTS 100 LD turbo	220-240	16	0,1	2300	115	36	0,68
VENTS 125 LD turbo	220-240	24	0,105	2400	209	36	0,84
VENTS 150 LD turbo	220-240	30	0,13	2400	310	39	1,10
VENTS 100 LD 12	12	14	1,5	2200	77	32	0,59
VENTS 125 LD 12	12	16	1,7	2300	149	33	0,72
VENTS 150 LD 12	12	24	2	2300	236	36	0,92

### Mounting example



### Overall dimensions

Model	Dimensions [mm]				
	Ø D	B	H	L	L1
VENTS 100 LD	100	152	120	126	30
VENTS 100 LD1	100	152	120	111	30
VENTS 125 LD	125	177	140	135	34
VENTS 125 LD1	125	177	140	116	34
VENTS 150 LD	150	206	165	154	36

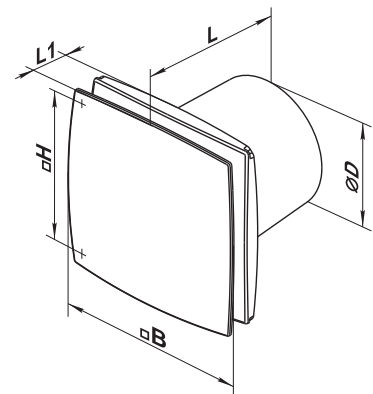

### Certificates



The fans meet the applicable safety and electromagnetic compatibility standards.

## VENTS LD Auto Series



Exhaust axial decorative fans with automatic louvre shutters with air capacity up to 345 m<sup>3</sup>/h

### Applications

- Continuous or periodic exhaust ventilation of bathroom, showers, kitchens and other utility spaces.
- Ventilation shaft mounting or duct connection.
- Low to medium air flow motion for short distances at low air resistance.
- Compatible with Ø 100, 125 and 150 mm air ducts.



Fan off - louvre shutters CLOSED



Fan on - louvre shutters OPEN



LDA Auto



LDA Auto Chrome



LDA Auto Gold

### Design

- Modern design and aesthetic look.
- The casing, impeller and front panel are made of high-quality and durable UV-resistant ABS plastic.
- Various decorative natural aluminium plates.
- The thermal actuator provides smooth opening and closing of the automatic louvre shutters that prevent air back drafting.
- The impeller design enhances the fan efficiency and prolongs the motor service life.
- Protection rating IP 24.

### Motor

- Reliable motor with low energy demand
- Designed for continuous operation and requires no maintenance.
- Equipped with overheating protection.

### Modifications and options



**LD Auto L** - the motor is equipped with ball bearings for long service life (appr. 40 thousand hours) and fan mounting at any angle. The bearings are maintenance-free and contain enough grease for the entire operating period.



**LD Auto turbo** - high-powered motor.



**LD Auto press** - 5-blade low-noise impeller with improved aerodynamics for higher fan capacity.



**LD Auto 12** - equipped with a reliable low-voltage motor, 12 V.



**LD Auto T** - equipped with a turn-off delay timer adjustable from 2 to 30 minutes.



**LD Auto TH** - equipped with a turn-off delay timer adjustable from 2 to 30 minutes and a humidity sensor adjustable from 60% to 90%.



**LD Auto V** - equipped with a pull cord switch.



**LD Auto VT** - equipped with a pull cord switch and a turn-off delay timer adjustable from 2 to 30 minutes.



**LD Auto VTH** - equipped with a pull cord switch, turn-off delay timer adjustable from 2 to 30 minutes and a humidity sensor adjustable from 60% to 90%.

### Control

#### Manual:

- The fan is controlled with a room light switch (not included into delivery set).
- The fan is controlled with a built-in pull cord switch "V". This option is not applicable for ceiling mounting.
- Speed control with a thyristor speed controller, refer Electric accessories. Several fans may be connected to one controller.

#### Automatic:

- Speed control with a an electronic control unit **BU-1-60**, refer Electric accessories. The control unit is available upon separate order.
- Fan control with a turn-off delay timer "T" that enables fan running from 2 to 30 minutes after turning the fan off.
- Fan control with a humidity sensor and turn-off delay timer "TH" that enables fan switching on and running until the indoor humidity drops below the set point adjustable from 60% to 90% and subsequent fan running within the set time before turning off.

### Mounting features

- The fan is mounted directly into the ventilation shaft.
- Flexible duct connection is recommended in case of the remote ventilation shaft location. The air duct is connected to the fan exhaust flange through a clamp.
- Fixing with screws.
- Suitable for ceiling mounting.
- The step-down transformer (TRF 220/12-25) enables connection of a low-voltage fan 12 V / 50 Hz to 220 V / 50 Hz power mains. Available upon separate order.

### Accessories



Air ducts

Grilles and hoods

Back valves

Speed controllers

Control unit

Transformer

Clamps

## Aerodynamic characteristics

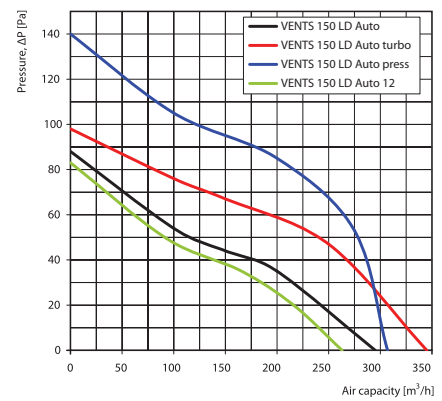
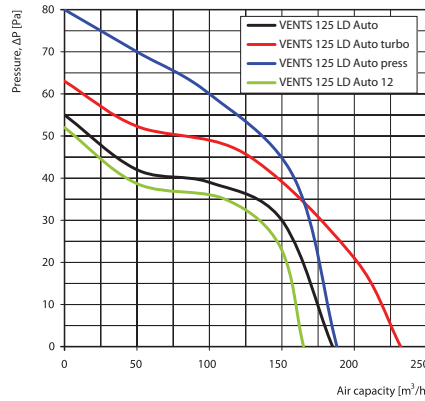
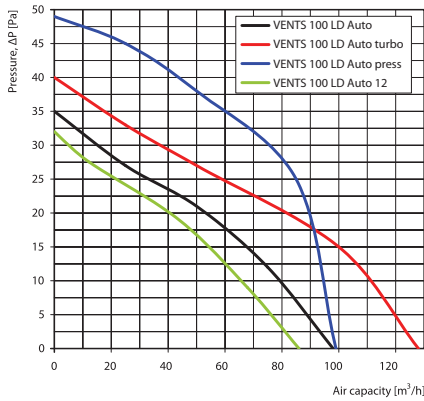

## Technical data

Model	Voltage [V] at 50 Hz	Power Consumption [W]	Current [A]	RPM [min <sup>-1</sup> ]	Maximum air capacity [m <sup>3</sup> /h]	Sound Pressure Level at 3 m [dB(A)]	Weight [kg]
VENTS 100 LD Auto	220-240	18	0,085	2300	98	34	0,73
VENTS 125 LD Auto	220-240	22	0,1	2400	185	35	0,83
VENTS 150 LD Auto	220-240	26	0,13	2400	295	39	1,14
VENTS 100 LD Auto turbo	220-240	20	0,1	2300	128	37	0,79
VENTS 125 LD Auto turbo	220-240	30	0,13	2400	232	37	0,89
VENTS 150 LD Auto turbo	220-240	32	0,13	2400	345	41	1,2
VENTS 100 LD Auto press	220-240	20	0,1	2300	99	37	0,73
VENTS 125 LD Auto press	220-240	30	0,13	2400	188	39	0,83
VENTS 150 LD Auto press	220-240	32	0,14	2400	307	41	1,14
VENTS 100 LD Auto 12	12	18	1,5	2200	86	33	0,72
VENTS 125 LD Auto 12	12	22	1,7	2300	165	34	0,82
VENTS 150 LD Auto 12	12	24	2	2300	263	38	1,13

## Mounting example



## Overall dimensions

Model	Dimensions [mm]			
	∅ D	B	L	L1
VENTS 100 LD Auto	99,5	205	110	60
VENTS 125 LD Auto	125	205	118	65
VENTS 150 LD Auto	150	240	137	81

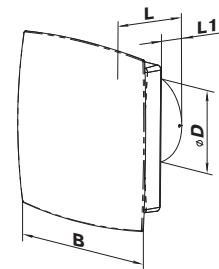

## Certificates



The fans meet the applicable safety and electromagnetic compatibility standards.



## VENTS LD light Series



Exhaust axial decorative fans with air capacity up to 310 m<sup>3</sup>/h

### Applications

- Continuous or periodic exhaust ventilation of bathroom, showers, kitchens and other utility spaces.
- Ventilation shaft mounting or duct connection.
- Low to medium air flow motion for short distances at low air resistance.
- Compatible with Ø 100, 125 and 150 mm air ducts.



LD Light blue



LD Light red

### Design

- Modern design and original look.
- The casing and the impeller are made of high-quality durable ABS plastic, UV resistant.
- Front panel edge is made of transparent plexiglass with LED illumination of various colours (blue, red, green).
- The impeller design enhances the fan efficiency and prolongs the motor service life.
- Protection rating IP 34.

### Motor

- Reliable motor with low energy demand.
- Designed for continuous operation and requires no maintenance.
- Equipped with overheating protection.

### Modifications and options



**LD Light K** – the fan is equipped with a back valve to prevent air backdrafting.



**LD Light L** – the motor is equipped with ball bearings for long service life (appr. 40 thousand hours) and fan mounting at any angle. The bearings are maintenance-free and contain enough grease for the entire operating period.



**LD Light turbo** – high-powered motor.



**LD Light 12** – equipped with a reliable low-voltage motor, 12 V.



**LD Light T** – equipped with a turn-off delay timer adjustable from 2 to 30 minutes.



**LD Light TH** – equipped with a turn-off delay timer adjustable from 2 to 30 minutes and a humidity sensor adjustable from 60% to 90%.



**LD Light V** – equipped with a pull cord switch.



**LD Light VT** – equipped with a pull cord switch and a turn-off delay timer adjustable from 2 to 30 minutes.



**LD Light VTH** – equipped with a pull cord switch, turn-off delay timer adjustable from 2 to 30 minutes and a humidity sensor adjustable from 60% to 90%.

### Control

#### Manual:

- The fan is controlled with a room light switch (not included into delivery set).
- The fan is controlled with a built-in pull cord switch "V". This option is not applicable for ceiling mounting.
- Speed control with a thyristor speed controller, refer Electric accessories. Several fans may be connected to one controller.

#### Automatic:

- Speed control with a an electronic control unit **BU-1-60**, refer the Electric accessories. The control unit is available upon separate order.
- Fan control with a turn-off delay timer "T" that enables fan running from 2 to 30 minutes after turning the fan off.
- Fan control with a humidity sensor and turn-off delay timer "TH" that enables fan switching on and running until the indoor humidity drops below the set point adjustable from 60% to 90% and subsequent fan running within the set time before turning off.

### Mounting features

- The fan is mounted directly into the ventilation shaft.
- Flexible duct connection is recommended in case of the remote ventilation shaft location. The air duct is connected to the fan exhaust flange through a clamp.
- Fixing to wall with screws.
- Suitable for ceiling mounting.
- The step-down transformer (TRF 220/12-25) enables connection of a low-voltage fan 12 V / 50 Hz to 220 V / 50 Hz power mains. Available upon separate order.

### Accessories

Air ducts



Grilles and hoods



Back valves



Speed controllers



Control unit



Transformer



Clamps



### Aerodynamic characteristics

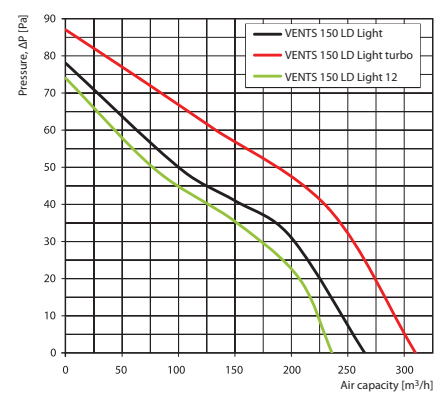
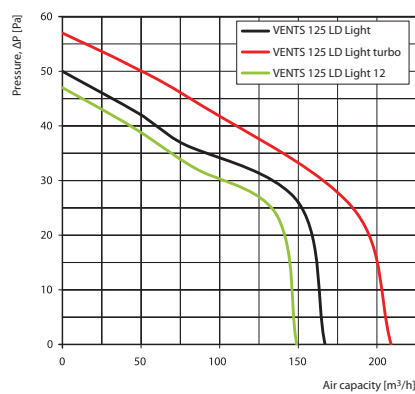
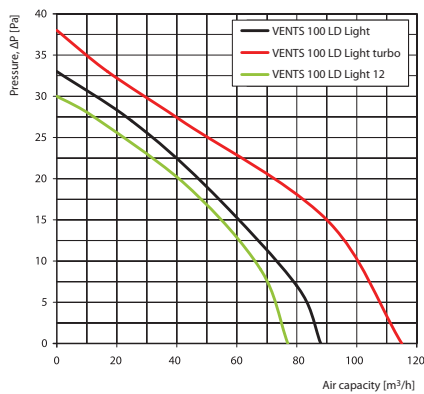

### Technical data

Model	Voltage [V] at 50 Hz	Power [W]	Current [A]	RPM [min <sup>-1</sup> ]	Maximum air capacity [m <sup>3</sup> /h]	Sound Pressure Level at 3 m [dB(A)]	Weight [kg]
VENTS 100 LD Light	220-240	14	0,085	2300	88	33	0,73
VENTS 125 LD Light	220-240	16	0,1	2400	167	34	0,89
VENTS 150 LD Light	220-240	24	0,13	2400	265	37	1,14
VENTS 100 LD Light turbo	220-240	16	0,1	2300	115	36	0,81
VENTS 125 LD Light turbo	220-240	24	0,105	2400	209	36	0,99
VENTS 150 LD Light turbo	220-240	30	0,13	2400	310	39	1,28
VENTS 100 LD Light 12	12	14	1,5	2200	77	32	0,72
VENTS 125 LD Light 12	12	16	1,7	2300	149	33	0,87
VENTS 150 LD Light 12	12	24	2	2300	236	36	1,10

### Mounting example



### Overall dimensions

Model	Overall dimensions [mm]			
	∅ D	B	L	L1
VENTS 100 LD Light	99,5	160	126	96
VENTS 125 LD Light	125	187	135	101
VENTS 150 LD Light	150	216	154	118

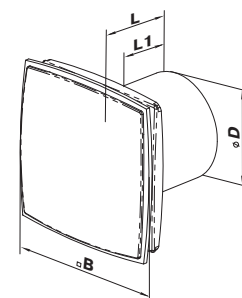

### Certificates



The fans meet the applicable safety and electromagnetic compatibility standards.

## VENTS LD Fresh time Series



Axial fans for exhaust ventilation with a built-in clock and capacity up to 115 m<sup>3</sup>/h

### Applications

- Continuous or periodic exhaust ventilation of bathroom, showers, kitchens and other utility spaces.
- Ventilation shaft mounting or duct connection.
- Low to medium air flow motion for short distances at low air resistance.
- Compatible with Ø 100 mm air ducts.

### Design

- A battery-powered quartz clock is built into the fan casing.
- Both Arabic and Roman hour plates are available on the front panel.
- Modern design and aesthetic look.
- The casing and the impeller are made of high-quality durable ABS plastic, UV resistant.
- The intellectual impeller design makes the fan efficiency high and the service life long.
- Protection rating IP 34.

### Motor

- Reliable and low-watt electric motor.
- Designed for continuous operation and requires no maintenance.
- Equipped with overheating protection.

### Modifications and Options

**LD Fresh time R** – fan with a Roman hour plate.



**LD Fresh time K** – fan is equipped with a backdraft damper for back flow preventing.



**LD Fresh time L** – the motor is equipped with ball bearings for long service life (appr. 40 thousand hours) and fan mounting at any angle. The bearings are maintenance-free and contain enough grease for the entire operating period.



**LD Fresh time turbo** – high-powered motor.



**LD Fresh time 12** – modification with low-voltage motor. 12 V AC power supply.



**LDT Fresh time** – equipped with a regulated timer with the operating time from 2 to 30 minutes.



**LDTH Fresh time** – equipped with a timer with the operating time from 2 to 30 minutes and a humidity sensor with the threshold value from 60 to 90%.



**LDV Fresh time** – equipped with a pull cord switch.



**LDVT Fresh time** – equipped with a pull cord switch and a regulated timer with the operating time adjustable from 2 to 30 minutes.



**LDVTH Fresh time** – equipped with a pull cord switch, regulated timer with the operating time adjustable from 2 to 30 minutes and a humidity sensor with the operating threshold range from 60% to 90%.

### Control

#### Manual:

- The fan is controlled by a room light switch. It is not included in the delivery package.
- Speed control is possible through a thyristor speed controller (see Electrical Accessories). Several fans may connected to the same regulator unit.

#### Automatic:

- By the electronic control unit **BU-1-60** (see Electrical Accessories). The control unit is supplied separately.
- By the timer **T** (the built-in run-out timer enables the fan operation within 2 to 30 minutes after the fan switching off).
- By the humidity sensor and timer **TH** (if the humidity level in the room exceeds the sensor threshold adjustable value within 60-90% the fan switches automatically on and operates until the humidity level drops to the standard level, after that the fan continues operating within the time period according to the timer setting, then shuts down).

### Mounting features

- The fan is mounted directly into the ventilation shaft.
- Flexible duct application is recommended in case of remote location of the ventilation shaft. The air duct is connected to the fan exhaust flange through a clamp.
- Fixed to wall by self-tapping screws.
- For 12 V low-voltage motor fan connection to 220 V / 50 Hz power mains use the step-down transformer TRF 220/12-25 that is available upon separate order.

### Accessories



Air ducts

Grilles and hoods

Backdraft damper

Speed controllers

Clamps

### Aerodynamic characteristics

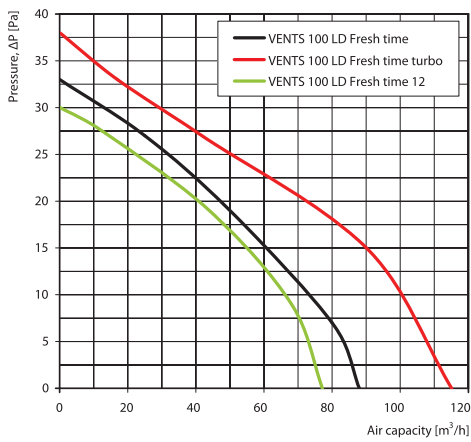

### Overall dimensions

Model	Dimensions [mm]				
	∅ D	B	H	L	L1
VENTS 100 LD Fresh time	100	152	120	135	40

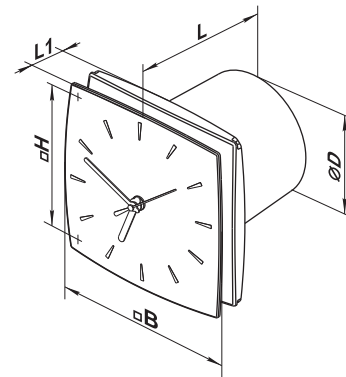

### Technical data

Model	Voltage [V] at 50 Hz	Power Consumption [W]	Current [A]	r.p.m.	Maximum air capacity [m³/h]	Sound Pressure Level at 3 m [dB(A)]	Weight [kg]
VENTS 100 LD Fresh time	220-240	14	0,085	2300	88	33	0,70
VENTS 100 LD Fresh time turbo	220-240	16	0,1	2300	115	36	0,70
VENTS 100 LD Fresh time 12	12	14	1,5	2200	77	32	0,70

### Mounting example



### Certificates

The fans meet the applicable safety and electromagnetic compatibility standards.

## VENTS Modern Series



Axial fans for exhaust ventilation with the capacity up to 310 m<sup>3</sup>/h

### Applications

- Continuous or periodic exhaust ventilation of bathroom, showers, kitchens and other utility spaces.
- Ventilation shaft mounting or duct connection.
- Low to medium air flow motion for short distances at low air resistance.
- Compatible with Ø 100, 125 and 150 mm air ducts.

### Design

- Modern design and aesthetic look.
- The casing and the impeller are made of high-quality durable ABS plastic, UV resistant.
- The front panel from organic glass.
- The intellectual impeller design makes the fan efficiency high and the service life long.
- Protection rating IP 34.

### Motor

- Reliable and low-watt electric motor.
- Designed for continuous operation and requires no maintenance.
- Equipped with overheating protection.

### Modifications and Options



**Modern K** – fan is equipped with a backdraft damper for back flow preventing.



**Modern L** – the motor is equipped with ball bearings for long service life (appr. 40 thousand hours) and fan mounting at any angle. The bearings are maintenance-free and contain enough grease for the entire operating period.



**Modern turbo** – high-powered motor.



**Modern 12** – modification with low-voltage motor. 12 V AC power supply.



**Modern T** – equipped with a regulated timer with the operating time from 2 to 30 minutes.



**Modern TH** – equipped with a timer with the operating time from 2 to 30 minutes and a humidity sensor with the threshold value from 60 to 90%.



**Modern V** – equipped with a pull cord switch.



**Modern VT** – equipped with a pull cord switch and a regulated timer with the operating time adjustable from 2 to 30 minutes.



**Modern VTH** – equipped with a pull cord switch, regulated timer with the operating time adjustable from 2 to 30 minutes and a humidity sensor with the operating threshold range from 60% to 90%.

### Control

#### Manual:

- The fan is controlled by a room light switch. It is not included in the delivery package.
- The fan is controlled by the built-in pull cord switch **V**. Not applied in case of ceiling mounting.
- Speed control is possible through a thyristor speed controller (see Electrical Accessories). Several fans may be connected to the same regulator unit.

#### Automatic:

- By the electronic control unit **BU-1-60** (see Electrical Accessories). The control unit is supplied separately.
- By the timer **T** (the built-in run-out timer enables the fan operation within 2 to 30 minutes after the fan switching off).
- By the humidity sensor and timer **TH** (if the humidity level in the room exceeds the sensor threshold adjustable value within 60-90% the fan switches automatically on and operates until the humidity level drops to the standard level, after that the fan continues operating within the time period according to the timer setting, then shuts down).

### Mounting features

- The fan is mounted directly into the ventilation shaft.
- Flexible duct application is recommended in case of remote location of the ventilation shaft. The air duct is connected to the fan exhaust flange through a clamp.
- Fixed to wall by self-tapping screws.
- Suitable for ceiling mounting.
- For 12 V low-voltage motor fan connection to 220 V / 50 Hz power mains use the step-down transformer TRF 220/12-25 that is available upon separate order.

### Accessories



Air ducts

Grilles and hoods

Backdraft damper

Speed controllers

Clamps

## Aerodynamic characteristics

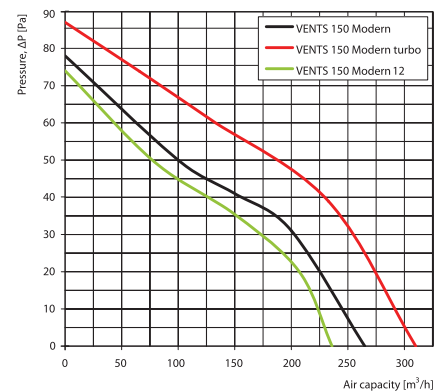
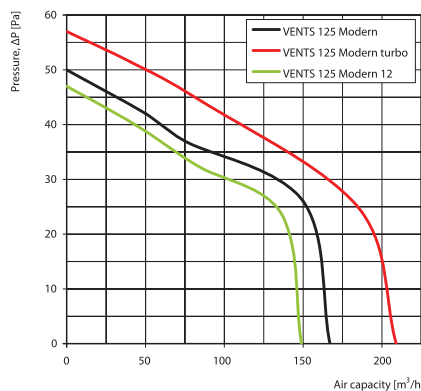
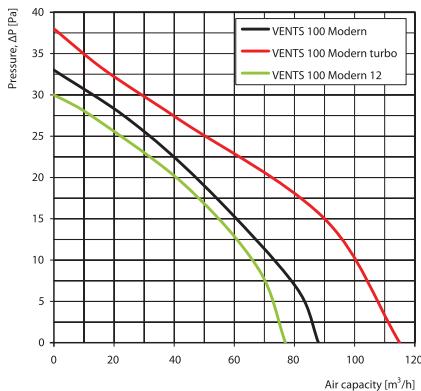

## Technical data

Model	Voltage [V] at 50 Hz	Power Consumption [W]	Current [A]	r.p.m.	Maximum air capacity [m³/h]	Sound Pressure Level at 3 m [dB(A)]	Weight [kg]
VENTS 100 Modern	220-240	14	0,085	2300	88	33	0,60
VENTS 125 Modern	220-240	16	0,1	2400	167	34	0,74
VENTS 150 Modern	220-240	24	0,13	2400	265	37	0,96
VENTS 100 Modern turbo	220-240	16	0,1	2300	115	36	0,68
VENTS 125 Modern turbo	220-240	24	0,105	2400	209	36	0,84
VENTS 150 Modern turbo	220-240	30	0,13	2400	310	39	1,10
VENTS 100 Modern 12	12	14	1,5	2200	77	32	0,59
VENTS 125 Modern 12	12	16	1,7	2300	149	33	0,72
VENTS 150 Modern 12	12	24	2	2300	236	36	0,92

## Mounting example



## Overall dimensions

Model	Dimensions [mm]			
	Ø D	B	L	L1
VENTS 100 Modern	100	170	130	35
VENTS 125 Modern	125	196	139	38
VENTS 150 Modern	150	226	157	39

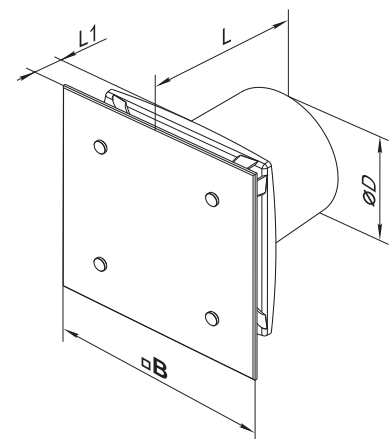

## Certificates



The fans meet the applicable safety and electromagnetic compatibility standards.

## VENTS Modern Auto Series



Exhaust axial decorative fans with automatic louvre shutters with air capacity up to 345 m<sup>3</sup>/h

### Applications

- Continuous or periodic exhaust ventilation of bathroom, showers, kitchens and other utility spaces.
- Ventilation shaft mounting or duct connection.
- Low to medium air flow motion for short distances at low air resistance.
- Compatible with Ø 100, 125 and 150 mm air ducts.



Fan off - louvre shutters CLOSED



Fan on - louvre shutters OPEN

### Design

- Modern design and aesthetic look.
- The casing and the impeller are made of high-quality durable ABS plastic, UV resistant.
- Front panel is made of white or black organic glass.
- The fan and motor are specially designed for silent operation.
- The impeller design enhances the fan efficiency and prolongs the motor service life.
- Protection rating IP 24

### Motor

- Reliable motor with low energy demand
- Designed for continuous operation and requires no maintenance.
- Equipped with overheating protection.

### Modifications and options



**Modern Auto L** - the motor is equipped with ball bearings for long service life (appr. 40 thousand hours) and fan mounting at any angle. The bearings are maintenance-free and contain enough grease for the entire operating period.



**Modern Auto turbo** - high-powered motor.



**Modern Auto press** - 5-blade low-noise impeller with improved aerodynamics for higher fan capacity.



**Modern Auto 12** - equipped with a reliable low-voltage motor, 12 V.



**Modern Auto T** - equipped with a turn-off delay timer adjustable from 2 to 30 minutes.



**Modern Auto TH** - equipped with a turn-off delay timer adjustable from 2 to 30 minutes and a humidity sensor adjustable from 60% to 90%.



**Modern Auto V** - equipped with a pull cord switch.



**Modern Auto VT** - equipped with a pull cord switch and a turn-off delay timer adjustable from 2 to 30 minutes.



**Modern Auto VTH** - equipped with a pull cord switch, turn-off delay timer adjustable from 2 to 30 minutes and a humidity sensor adjustable from 60% to 90%.

### Control

#### Manual:

- The fan is controlled with a room light switch (not included into delivery set).
- The fan is controlled with a built-in pull cord switch "V". This option is not applicable for ceiling mounting.
- Speed control with a thyristor speed controller, refer Electric accessories. Several fans may be connected to one controller.

#### Automatic:

- Speed control with a an electronic control unit **BU-1-60**, refer Electric accessories. The control unit is available upon separate order.
- Fan control with a turn-off delay timer "T" that enables fan running from 2 to 30 minutes after turning the fan off.
- Fan control with a humidity sensor and turn-off delay timer "TH" that enables fan switching on and running until the indoor humidity drops below the set point adjustable from 60% to 90% and subsequent fan running within the set time before turning off.

### Mounting features

- The fan is mounted directly into the ventilation shaft.
- Flexible duct connection is recommended in case of the remote ventilation shaft location. The air duct is connected to the fan exhaust flange through a clamp.
- Fixing with screws.
- Suitable for ceiling mounting.
- The step-down transformer (TRF 220/12-25) enables connection of a low-voltage fan 12 V / 50 Hz to 220 V / 50 Hz power mains. Available upon separate order.

### Accessories



## Aerodynamic characteristics

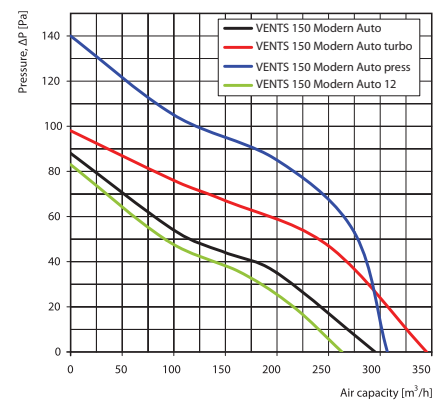
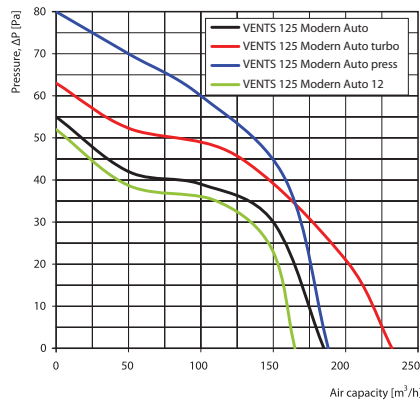
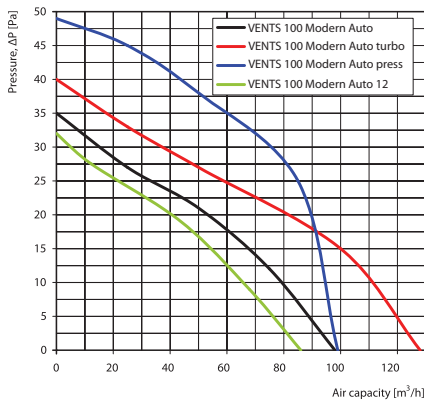

## Technical data

Model	Voltage [V] at 50 Hz	Power Consumption [W]	Current [A]	RPM [min <sup>-1</sup> ]	Maximum air capacity [m <sup>3</sup> /h]	Sound Pressure Level at 3 m [dB(A)]	Weight [kg]
VENTS 100 Modern Auto	220-240	18	0,085	2300	98	34	0,85
VENTS 125 Modern Auto	220-240	22	0,1	2400	185	35	1,00
VENTS 150 Modern Auto	220-240	26	0,13	2400	295	39	1,31
VENTS 100 Modern Auto turbo	220-240	20	0,1	2300	128	37	0,90
VENTS 125 Modern Auto turbo	220-240	30	0,13	2400	232	37	1,06
VENTS 150 Modern Auto turbo	220-240	32	0,13	2400	345	41	1,28
VENTS 100 Modern Auto press	220-240	20	0,1	2300	99	37	0,85
VENTS 125 Modern Auto press	220-240	30	0,13	2400	188	39	1,00
VENTS 150 Modern Auto press	220-240	32	0,14	2400	307	41	1,31
VENTS 100 Modern Auto 12	12	18	1,5	2200	86	33	0,84
VENTS 125 Modern Auto 12	12	22	1,7	2300	165	34	0,99
VENTS 150 Modern Auto 12	12	24	2	2300	263	38	1,29

## Mounting example



## Overall dimensions

Model	Dimensions [mm]				
	Ø D	B	H	L	L1
VENTS 100 Modern Auto	99,5	196	196	117	60
VENTS 125 Modern Auto	125	220	220	124	65
VENTS 150 Modern Auto	150	242	242	139	81

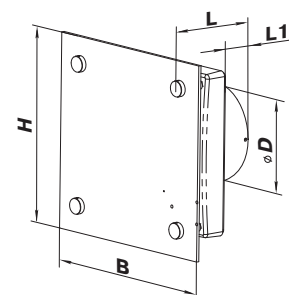

## Certificates



The fans meet the applicable safety and electromagnetic compatibility standards.



## VENTS Domino Series



Exhaust decorative axial fan with air capacity up to 310 m<sup>3</sup>/h

### Applications

- Continuous or periodic exhaust ventilation of bathroom, showers, kitchens and other utility spaces.
- Ventilation shaft mounting or duct connection.
- Low to medium air flow motion for short distances at low air resistance.
- Compatible with Ø 100, 125 and 150 mm air ducts.



Domino 1



Domino 2

### Design

- Modern design and original look.
- The casing and the impeller are made of high-quality durable ABS plastic, UV resistant.
- Front panel is made of white, black or red organic glass in various combinations.
- The impeller design enhances the fan efficiency and prolongs the motor service life.
- Protection rating IP 34.

### Motor

- Reliable motor with low energy demand.
- Designed for continuous operation and requires no maintenance.
- Equipped with overheating protection.

### Modifications and options



**Domino K** – the fan is equipped with a back valve to prevent air backdrafting.



**Domino L** – the motor is equipped with ball bearings for long service life (appr. 40 thousand hours) and fan mounting at any angle. The bearings are maintenance-free and contain enough grease for the entire operating period.



**Domino turbo** – high-powered motor.



**Domino 12** – equipped with a reliable low-voltage motor, 12 V.



**Domino T** – equipped with a turn-off delay timer adjustable from 2 to 30 minutes.



**Domino TH** – equipped with a turn-off delay timer adjustable from 2 to 30 minutes and a humidity sensor adjustable from 60% to 90%.



**Domino V** – equipped with a pull cord switch.



**Domino VT** – equipped with a pull cord switch and a turn-off delay timer adjustable from 2 to 30 minutes.



**Domino VTH** – equipped with a pull cord switch, turn-off delay timer adjustable from 2 to 30 minutes and a humidity sensor adjustable from 60% to 90%.

### Control

#### Manual:

- The fan is controlled with a room light switch (not included into delivery set).
- The fan is controlled with a built-in pull cord switch "V". This option is not applicable for ceiling mounting.
- Speed control with a thyristor speed controller, refer the Electric accessories. Several fans may be connected to one controller.

#### Automatic:

- Speed control with a an electronic control unit **BU-1-60**, refer the Electric accessories. The control unit is available upon separate order.
- Fan control with a turn-off delay timer "T" that enables fan running from 2 to 30 minutes after turning the fan off.
- Fan control with a humidity sensor and turn-off delay timer "TH" that enables fan switching on and running until the indoor humidity drops below the set point adjustable from 60% to 90% and subsequent fan running within the set time before turning off.

### Mounting features

- The fan is mounted directly into the ventilation shaft.
- Flexible duct connection is recommended in case of the remote ventilation shaft location. The air duct is connected to the fan exhaust flange through a clamp.
- Fixing to wall with screws.
- Suitable for ceiling mounting.
- The step-down transformer (TRF 220/12-25) enables connection of a low-voltage fan 12 V / 50 Hz to 220 V / 50 Hz power mains. Available upon separate order.

### Accessories



## Aerodynamic characteristics

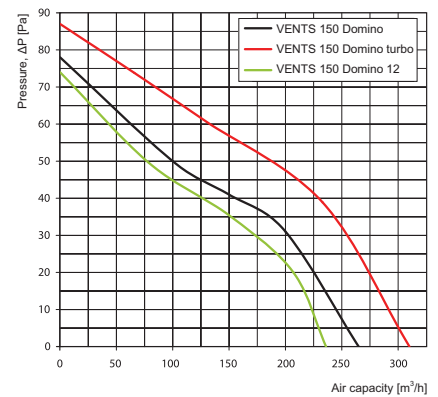
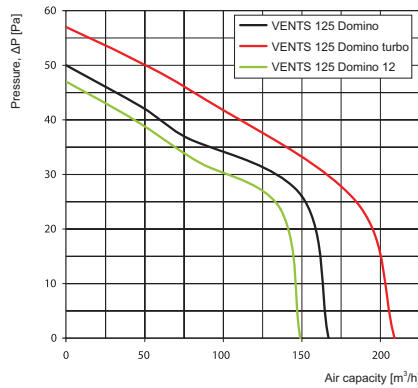
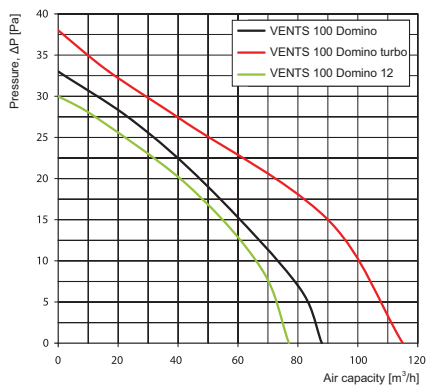

## Technical data

Model	Voltage [V] at 50 Hz	Power [W]	Current [A]	RPM [min <sup>-1</sup> ]	Maximum air capacity [m <sup>3</sup> /h]	Sound Pressure Level at 3 m [dB(A)]	Weight [kg]
VENTS 100 Domino	220-240	14	0,085	2300	88	33	0,86
VENTS 125 Domino	220-240	16	0,1	2400	167	34	1,11
VENTS 150 Domino	220-240	24	0,13	2400	265	37	1,35
VENTS 100 Domino turbo	220-240	16	0,1	2300	115	36	0,94
VENTS 125 Domino turbo	220-240	24	0,105	2400	209	36	1,18
VENTS 150 Domino turbo	220-240	30	0,13	2400	310	39	1,49
VENTS 100 Domino 12	12	14	1,5	2200	77	32	0,88
VENTS 125 Domino 12	12	16	1,7	2300	149	33	1,06
VENTS 150 Domino 12	12	24	2	2300	236	36	1,31

## Mounting example



## Overall dimensions

Model	Dimensions [mm]				
	H	B	Ø D	L	L1
VENTS 100 Domino	170	170	99,5	138	96
VENTS 125 Domino	196	196	124,5	143	101
VENTS 150 Domino	226	226	149,5	161	118

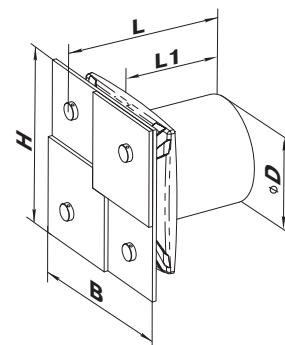

## Certificates



The fans meet the applicable safety and electromagnetic compatibility standards.

## VENTS Z Series



Axial design fans for exhaust ventilation with the capacity up to 358 m<sup>3</sup>/h

### Applications

- Continuous or periodic exhaust ventilation of bathroom, showers, kitchens and other utility spaces.
- Ventilation shaft mounting or duct connection.
- Low to medium air flow motion for short distances at low air resistance.
- Compatible with Ø 100, 125 and 150 mm air ducts.

### Design

- Modern design and aesthetic look.
- The polished steel front panel with various ornamental modifications.
- The casing and the impeller are made of high-quality durable ABS plastic, UV resistant.
- The intellectual impeller design makes the fan efficiency high and the service life long.
- Protection rating IP 24.

### Motor

- Reliable and low-watt electric motor.
- Designed for continuous operation and requires no maintenance.
- Equipped with overheating protection.

### Modifications and Options



**Z L** – The motor is equipped with ball bearings for long service life (appr. 40 thousand hours) and fan mounting at any angle. The bearings are maintenance-free and contain enough grease for the entire operating period.



**Z turbo** – high-powered motor.



**Z 12** – modification with low-voltage motor. 12 V AC power supply.

### Control

#### Manual:

- The fan is controlled by a room light switch. It is not included in the delivery package.
- Speed control is possible through a thyristor speed controller (see Electrical Accessories). Several fans may be connected to the same regulator unit.

#### Automatic:

- By the electronic control unit **BU-1-60** (see Electrical Accessories). The control unit is supplied separately.

### Mounting features

- The fan is mounted directly into the ventilation shaft.
- Flexible duct application is recommended in case of remote location of the ventilation shaft. The air duct is connected to the fan exhaust flange through a clamp.
- Fixed to wall by self-tapping screws.
- For 12 V low-voltage motor fan connection to 220 V / 50 Hz power mains use the step-down transformer TRF 220/12-25 that is available upon separate order.

### Front panel modifications



Z 1



Z 2



Z 3



Z 4



Z 5



Z 6

### Accessories



Air ducts

Grilles and hoods

Backdraft damper

Speed controllers

Clamps

## Aerodynamic characteristics

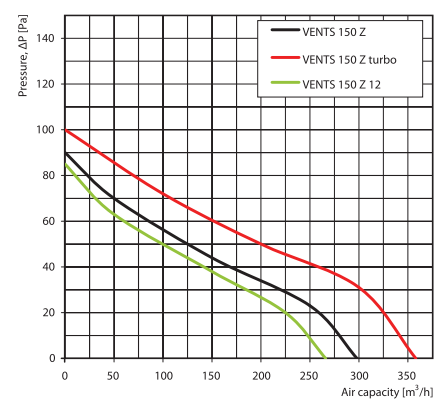
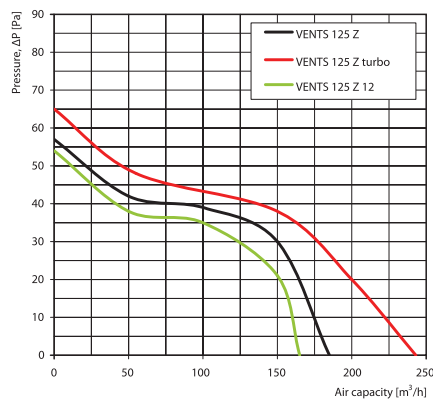
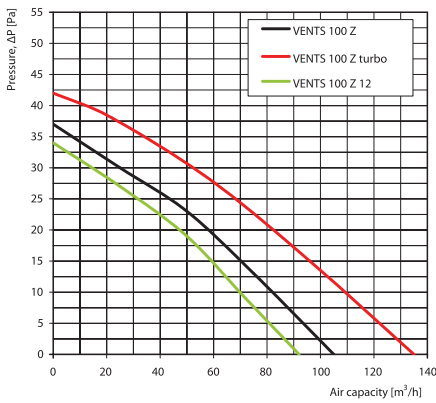

## Technical data

Model	Voltage [V] at 50 Hz	Power Consumption [W]	Current [A]	r.p.m.	Maximum air capacity [m³/h]	Sound Pressure Level at 3 m [dB(A)]	Weight [kg]
VENTS 100 Z	220-240	14	0,085	2300	105	37	0,41
VENTS 125 Z	220-240	16	0,1	2400	185	38	0,48
VENTS 150 Z	220-240	24	0,13	2400	298	40	0,80
VENTS 100 Z turbo	220-240	16	0,1	2300	135	38	0,41
VENTS 125 Z turbo	220-240	24	0,105	2400	243	39	0,48
VENTS 150 Z turbo	220-240	30	0,13	2400	358	44	0,80
VENTS 100 Z 12	12	14	1,5	2200	92	36	0,40
VENTS 125 Z 12	12	16	1,33	2300	165	37	0,46
VENTS 150 Z 12	12	24	2	2300	266	39	0,76

## Mounting example



## Overall dimensions

Model	Dimensions [mm]				
	Ø D	B	H	L	L1
VENTS 100 Z	100	181	120	143	56
VENTS 125 Z	125	208	140	143	56
VENTS 150 Z	150	231	165	166	56

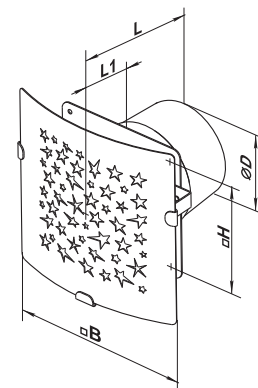

## Certificates



The fans meet the applicable safety and electromagnetic compatibility standards.

## VENTS Z star Series



Axial design fans for exhaust ventilation with the capacity up to 302 m<sup>3</sup>/h

### Applications

- Continuous or periodic exhaust ventilation of bathroom, showers, kitchens and other utility spaces.
- Ventilation shaft mounting or duct connection.
- Low to medium air flow motion for short distances at low air resistance.
- Compatible with Ø 100, 125 and 150 mm air ducts.



LED lamp, 2 W

### Design

- The polished steel front panel with various ornamental modifications.
- A 2 W LED lamp is integrated into the fan casing.
- Modern design and aesthetic look.
- The casing and the impeller are made of high-quality durable ABS plastic, UV resistant.
- The intellectual impeller design makes the fan efficiency high and the service life long.
- Protection rating IP 24.

### Motor

- Reliable and low-watt electric motor.
- Designed for continuous operation and requires no maintenance.
- Equipped with overheating protection.

### Modifications and Options



**Z star K** – fan is equipped with a backdraft damper for back flow preventing.



**Z star L** – the motor is equipped with ball bearings for long service life (appr. 40 thousand hours) and fan mounting at any angle. The bearings are maintenance-free and contain enough grease for the entire operating period.



**Z star turbo** – high-powered motor.



**Z star 12** – modification with low-voltage motor. 12 V AC power supply.



**Z star T\*** – equipped with a regulated timer with the operating time from 2 to 30 minutes.



**Z star TH\*** – equipped with a timer with the operating time from 2 to 30 minutes and a humidity sensor with the threshold value from 60 to 90%.

\* only for Ø 100 mm fans

### Control

#### Manual:

- The fan is controlled by a room light switch. It is not included in the delivery package.
- Speed control is possible through a thyristor speed controller (see Electrical Accessories). Several fans may be connected to the same regulator unit.

#### Automatic:

- By the electronic control unit **BU-1-60** (see Electrical Accessories). The control unit is supplied separately.
- By the timer **T** (the built-in run-out timer enables the fan operation within 2 to 30 minutes after the fan switching off).
- By the humidity sensor and timer **TH** (if the humidity level in the room exceeds the sensor threshold adjustable value within 60-90% the fan switches automatically on and operates until the humidity level drops to the standard level, after that the fan continues operating within the time period according to the timer setting, then shuts down).

### Mounting features

- The fan is mounted directly into the ventilation shaft.
- Flexible duct application is recommended in case of remote location of the ventilation shaft. The air duct is connected to the fan exhaust flange through a clamp.
- Fixed to wall by self-tapping screws.
- Both parallel or separate switching of the fan and the built-in lamp (refer wiring diagrams).
- For 12 V low-voltage motor fan connection to 220 V / 50 Hz power mains use the step-down transformer TRF 220/12-25 that is available upon separate order.

### Front panel modifications



Z star 1



Z star 2



Z star 3



Z star 4



Z star 5



Z star 6

### Accessories



Air ducts

Grilles and hoods

Backdraft damper

Speed controllers

Clamps

### Aerodynamic characteristics

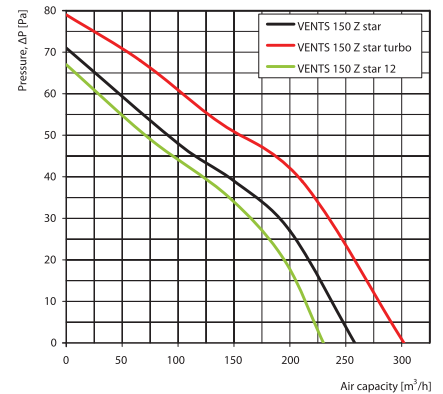
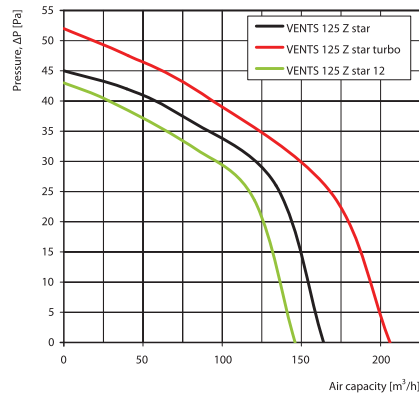
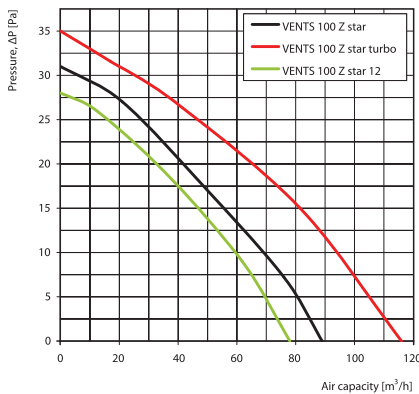

### Technical data

Model	Voltage [V] at 50 Hz	Power Consumption [W]	Current [A]	r.p.m.	Maximum air capacity [m³/h]	Sound Pressure Level at 3 m [dB(A)]	Weight [kg]
VENTS 100 Z star	220-240	14	0,085	2300	89	33	0,61
VENTS 125 Z star	220-240	16	0,1	2400	164	34	0,75
VENTS 150 Z star	220-240	24	0,13	2400	258	37	0,94
VENTS 100 Z star turbo	220-240	16	0,1	2300	116	36	0,69
VENTS 125 Z star turbo	220-240	24	0,105	2400	206	36	0,83
VENTS 150 Z star turbo	220-240	30	0,13	2400	302	39	1,08
VENTS 100 Z star 12	12	14	1,5	2200	78	32	0,60
VENTS 125 Z star 12	12	16	1,7	2300	146	33	0,73
VENTS 150 Z star 12	12	24	2	2300	230	36	0,90

### Mounting example



### Overall dimensions

Model	Dimensions [mm]				
	Ø D	B	H	L	L1
VENTS 100 Z star	100	181	120	148	56
VENTS 125 Z star	125	204	140	154	56
VENTS 150 Z star	150	231	165	171	56
VENTS 100 Z star T	98	183	122	151	65
VENTS 100 Z star TH	98	183	122	151	65

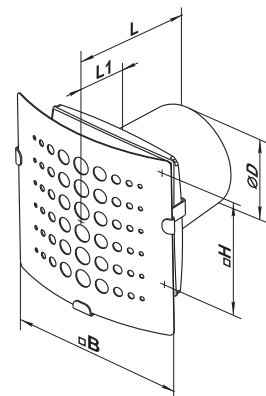

### Certificates



The fans meet the applicable safety and electromagnetic compatibility standards.

## VENTS Vitro Series



Axial design fans for exhaust ventilation with the capacity up to 358 m<sup>3</sup>/h

### Applications

- Continuous or periodic exhaust ventilation of bathroom, showers, kitchens and other utility spaces.
- Ventilation shaft mounting or duct connection.
- Low to medium air flow motion for short distances at low air resistance.
- Compatible with Ø 100, 125 and 150 mm air ducts.

### Design

- The glass front panel with various ornamental modifications.
- Modern design and aesthetic look.
- The casing and the impeller are made of high-quality durable ABS plastic, UV resistant.
- The intellectual impeller design makes the fan efficiency high and the service life long.
- Protection rating IP 24.

### Motor

- Reliable and low-watt electric motor.
- Designed for continuous operation and requires no maintenance.
- Equipped with overheating protection.

### Modifications and Options



**Vitro L** – the motor is equipped with ball bearings for long service life (appr. 40 thousand hours) and fan mounting at any angle. The bearings are maintenance-free and contain enough grease for the entire operating period.



**Vitro turbo** – high-powered motor.



**Vitro 12** – modification with low-voltage motor. 12 V AC power supply.

### Control

#### Manual:

- The fan is controlled by a room light switch. It is not included in the delivery package.
- Speed control is possible through a thyristor speed controller (see Electrical Accessories). Several fans may be connected to the same regulator unit.

#### Automatic:

- By the electronic control unit BU-1-60 (see Electrical Accessories). The control unit is supplied separately.

### Mounting features

- The fan is mounted directly into the ventilation shaft.
- Flexible duct application is recommended in case of remote location of the ventilation shaft. The air duct is connected to the fan exhaust flange through a clamp.
- Fixed to wall by self-tapping screws.
- For 12 V low-voltage motor fan connection to 220 V / 50 Hz power mains use the step-down transformer TRF 220/12-25 that is available upon separate order.

### Front panel modifications



Vitro 1



Vitro 2



Vitro 3



Vitro 4



Vitro 5



Vitro 6

### Accessories



Air ducts

Grilles and hoods

Backdraft damper

Speed controllers

Clamps

### Aerodynamic characteristics

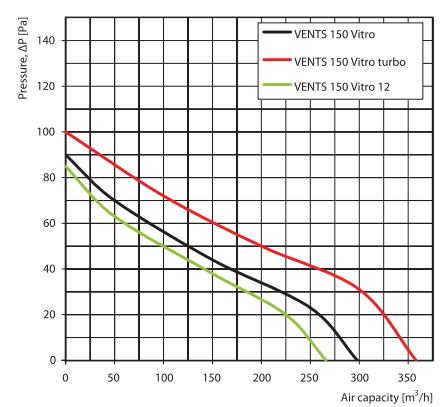
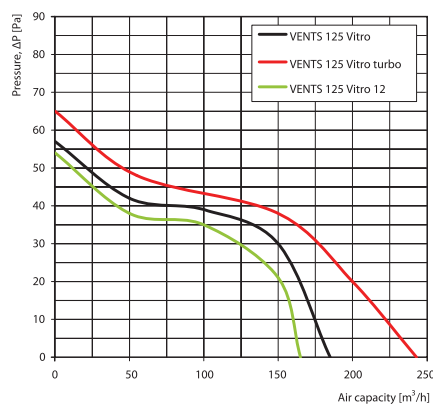
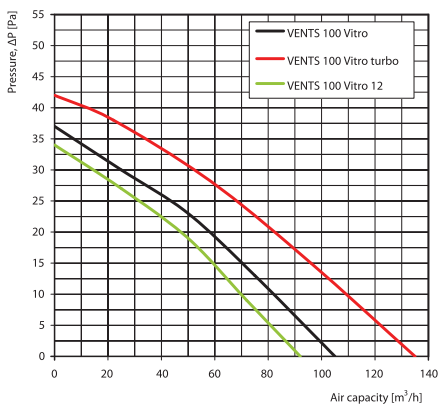

### Technical data

Model	Voltage [V] at 50 Hz	Power Consumption [W]	Current [A]	r.p.m.	Maximum air capacity [m³/h]	Sound Pressure Level at 3 m [dB(A)]	Weight [kg]
VENTS 100 Vitro	220-240	14	0,085	2300	105	37	0,41
VENTS 125 Vitro	220-240	16	0,1	2400	185	38	0,48
VENTS 150 Vitro	220-240	24	0,13	2400	298	40	0,80
VENTS 100 Vitro turbo	220-240	16	0,1	2300	135	38	0,41
VENTS 125 Vitro turbo	220-240	24	0,105	2400	243	39	0,48
VENTS 150 Vitro turbo	220-240	30	0,13	2400	358	44	0,80
VENTS 100 Vitro 12	12	14	1,5	2200	92	36	0,40
VENTS 125 Vitro 12	12	16	1,33	2300	165	37	0,46
VENTS 150 Vitro 12	12	24	2	2300	266	39	0,76

### Mounting example



### Overall dimensions

Model	Dimensions [mm]				
	Ø D	B	H	L	L1
VENTS 100 Vitro	100	183	120	145	58
VENTS 125 Vitro	125	205	140	146	58
VENTS 150 Vitro	150	233	165	169	58

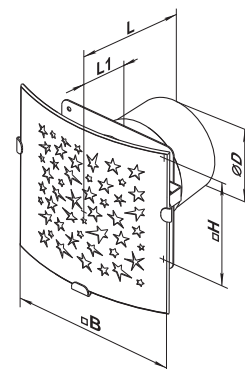

### Certificates



The fans meet the applicable safety and electromagnetic compatibility standards.



## VENTS Vitro star Series



Axial design fans for exhaust ventilation with the capacity up to 302 m<sup>3</sup>/h

### Applications

- Continuous or periodic exhaust ventilation of bathroom, showers, kitchens and other utility spaces.
- Ventilation shaft mounting or duct connection.
- Low to medium air flow motion for short distances at low air resistance.
- Compatible with Ø 100, 125 and 150 mm air ducts.



LED lamp, 2 W

### Design

- The glass front panel with various ornamental modifications.
- Modern design and aesthetic look.
- The casing and the impeller are made of high-quality durable ABS plastic, UV resistant.
- The intellectual impeller design makes the fan efficiency high and the service life long.
- A 2 W LED lamp is integrated into the fan casing.
- Protection rating IP 24.

### Motor

- Reliable and low-watt electric motor.
- Designed for continuous operation and requires no maintenance.
- Equipped with overheating protection.

### Modifications and Options



**Vitro star K** – fan is equipped with a backdraft damper for back flow preventing.



**Vitro star L** – the motor is equipped with ball bearings for long service life (appr. 40 thousand hours) and fan mounting at any angle. The bearings are maintenance-free and contain enough grease for the entire operating period.



**Vitro star turbo** – high-powered motor.



**Vitro star 12** – modification with low-voltage motor. 12 V AC power supply.



**Vitro star T\*** – equipped with a regulated timer with the operating time from 2 to 30 minutes.



**Vitro star TH\*** – equipped with a timer with the operating time from 2 to 30 minutes and a humidity sensor with the threshold value from 60 to 90%.

\* only for 100 mm fans

### Control

#### Manual:

- The fan is controlled by a room light switch. It is not included in the delivery package.
- Speed control is possible through a thyristor speed controller (see Electrical Accessories). Several fans may be connected to the same regulator unit.

#### Automatic:

- By the electronic control unit **BU-1-60** (see Electrical Accessories). The control unit is supplied separately.
- By the timer **T** (the built-in run-out timer enables the fan operation within 2 to 30 minutes after the fan switching off).
- By the humidity sensor and timer **TH** (if the humidity level in the room exceeds the sensor threshold adjustable value within 60-90% the fan switches automatically on and operates until the humidity level drops to the standard level, after that the fan continues operating within the time period according to the timer setting, then shuts down).

### Mounting features

- The fan is mounted directly into the ventilation shaft.
- Flexible duct application is recommended in case of remote location of the ventilation shaft. The air duct is connected to the fan exhaust flange through a clamp.
- Fixed to wall by self-tapping screws.
- Both parallel or separate switching of the fan and the built-in lamp (refer wiring diagrams).
- For 12 V low-voltage motor fan connection to 220 V / 50 Hz power mains use the step-down transformer TRF 220/12-25 that is available upon separate order.

### Front panel modifications



Vitro star 1



Vitro star 2



Vitro star 3



Vitro star 4



Vitro star 5



Vitro star 6

### Accessories



## Aerodynamic characteristics

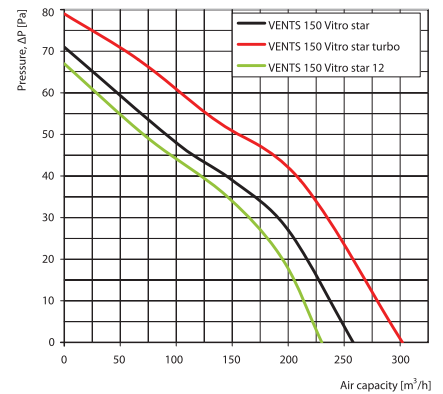
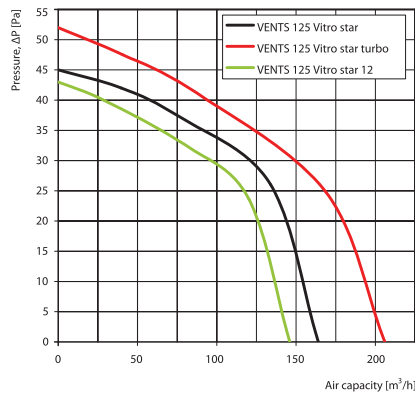
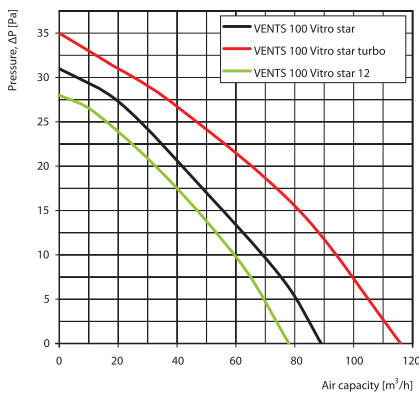

## Technical data

Model	Voltage [V] at 50 Hz	Power Consumption [W]	Current [A]	r.p.m.	Maximum air capacity [m³/h]	Sound Pressure Level at 3 m [dB(A)]	Weight [kg]
VENTS 100 Vitro star	220-240	14	0,085	2300	89	33	0,61
VENTS 125 Vitro star	220-240	16	0,1	2400	164	34	0,75
VENTS 150 Vitro star	220-240	24	0,13	2400	258	37	0,94
VENTS 100 Vitro star turbo	220-240	16	0,1	2300	116	36	0,69
VENTS 125 Vitro star turbo	220-240	24	0,105	2400	206	36	0,83
VENTS 150 Vitro star turbo	220-240	30	0,13	2400	302	39	1,08
VENTS 100 Vitro star 12	12	14	1,5	2200	78	32	0,60
VENTS 125 Vitro star 12	12	16	1,7	2300	146	33	0,73
VENTS 150 Vitro star 12	12	24	2	2300	230	36	0,90

## Mounting example



## Overall dimensions

Model	Dimensions [mm]				
	Ø D	B	H	L	L1
VENTS 100 Vitro star	100	183	120	151	58
VENTS 125 Vitro star	125	205	140	156	58
VENTS 150 Vitro star	150	233	165	173	58
VENTS 100 Vitro star T	98	183	122	151	65
VENTS 100 Vitro star TH	98	183	122	151	65

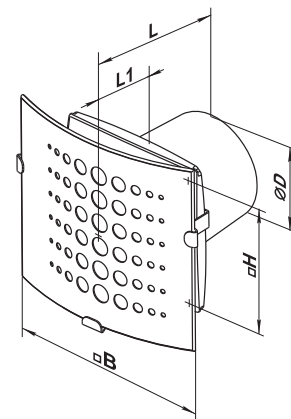

## Certificates

IP 24 The fans meet the applicable safety and electromagnetic compatibility standards.

## VENTS X Series



Axial decorative fans for exhaust ventilation with the capacity up to 302 m<sup>3</sup>/h

### Applications

- Continuous or periodic exhaust ventilation of bathroom, showers, kitchens and other utility spaces.
- Ventilation shaft mounting or duct connection.
- Low to medium air flow motion for short distances at low air resistance.
- Compatible with Ø 100, 125 and 150 mm air ducts.

### Design

- Modern design and aesthetic look.
- The casing and the impeller are made of high-quality durable ABS plastic, UV resistant.
- The intellectual impeller design makes the fan efficiency high and the service life long.
- Decorative replaceable colour covers: light blue, bright green, yellow and pink.
- Protection rating IP 24.

### Motor

- Reliable and low-watt electric motor.
- Designed for continuous operation and requires no maintenance.
- Equipped with overheating protection.

### Modifications and Options

**X alumat** – fan with a matt gray painted front plate.



**X K** – fan is equipped with a backdraft damper for back flow preventing.



**X L** – the motor is equipped with ball bearings for long service life (appr. 40 thousand hours) and fan mounting at any angle. The bearings are maintenance-free and contain enough grease for the entire operating period.



**X turbo** – high-powered motor.



**X 12** – modification with low-voltage motor. 12 V AC power supply.



**X T** – equipped with a regulated timer with the operating time from 2 to 30 minutes.



**XTH** – equipped with a timer with the operating time from 2 to 30 minutes and a humidity sensor with the threshold value from 60 to 90%.



**XV** – equipped with a pull cord switch.



**XVT** – equipped with a pull cord switch and a regulated timer with the operating time adjustable from 2 to 30 minutes.



**XVTH** – equipped with a pull cord switch, regulated timer with the operating time adjustable from 2 to 30 minutes and a humidity sensor with the operating threshold range from 60% to 90%.

### Control

#### Manual:

- The fan is controlled by a room light switch. It is not included in the delivery package.
- The fan is controlled by the built-in pull cord switch **V**. Not applied in case of ceiling mounting.
- Speed control is possible through a thyristor speed controller (see Electrical Accessories). Several fans may be connected to the same regulator unit.

#### Automatic:

- By the electronic control unit **BU-1-60** (see Electrical Accessories). The control unit is supplied separately.
- By the timer **T** (the built-in run-out timer enables the fan operation within 2 to 30 minutes after the fan switching off).
- By the humidity sensor and timer **TH** (if the humidity level in the room exceeds the sensor threshold adjustable value within 60-90% the fan switches automatically on and operates until the humidity level drops to the standard level, after that the fan continues operating within the time period according to the timer setting, then shuts down).

### Mounting features

- The fan is mounted directly into the ventilation shaft.
- Flexible duct application is recommended in case of remote location of the ventilation shaft. The air duct is connected to the fan exhaust flange through a clamp.
- Fixed to wall by self-tapping screws.
- Suitable for ceiling mounting.
- For 12 V low-voltage motor fan connection to 220 V / 50 Hz power mains use the step-down transformer TRF 220/12-25 that is available upon separate order.

### Accessories



Air ducts

Grilles and hoods

Backdraft damper

Speed controllers

Clamps

### Aerodynamic characteristics

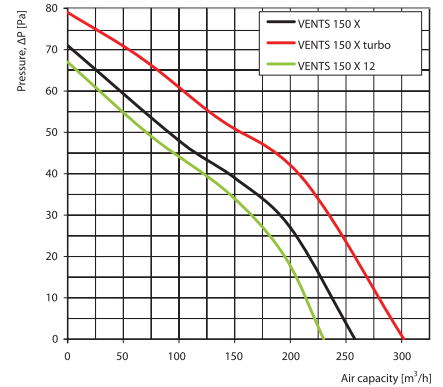
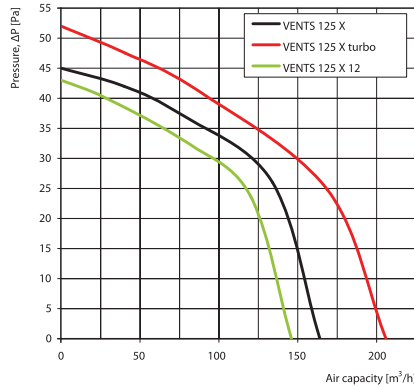
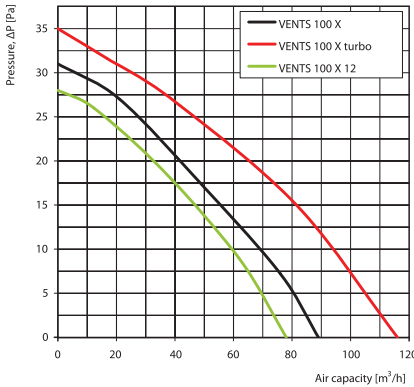

### Technical data

Model	Voltage [V] at 50 Hz	Power Consumption [W]	Current [A]	r.p.m.	Maximum air capacity [m <sup>3</sup> /h]	Sound Pressure Level at 3 m [dB(A)]	Weight [kg]
VENTS 100 X	220-240	14	0,085	2300	89	33	0,61
VENTS 125 X	220-240	16	0,1	2400	164	34	0,75
VENTS 150 X	220-240	24	0,13	2400	258	37	0,94
VENTS 100 X turbo	220-240	16	0,1	2300	116	36	0,69
VENTS 125 X turbo	220-240	24	0,105	2400	206	36	0,83
VENTS 150 X turbo	220-240	30	0,13	2400	302	39	1,08
VENTS 100 X 12	12	14	1,5	2200	78	32	0,60
VENTS 125 X 12	12	16	1,7	2300	146	33	0,73
VENTS 150 X 12	12	24	2	2300	230	36	0,90

### Mounting example



### Overall dimensions

Model	Dimensions [mm]				
	Ø D	B	H	L	L1
VENTS 100 X	100	152	120	125	30
VENTS 125 X	125	177	140	143	42
VENTS 150 X	150	205	165	160	42

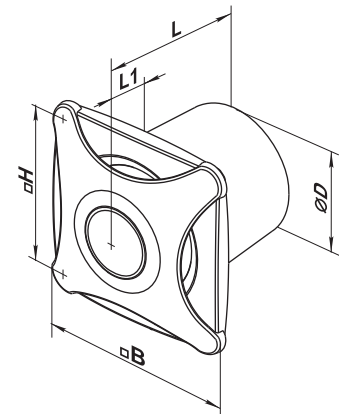

### Certificates



The fans meet the applicable safety and electromagnetic compatibility standards.

## VENTS X star Series



Axial decorative fans for exhaust ventilation with the capacity up to 302 m<sup>3</sup>/h

### Applications

- Continuous or periodic exhaust ventilation of bathroom, showers, kitchens and other utility spaces.
- Ventilation shaft mounting or duct connection.
- Low to medium air flow motion for short distances at low air resistance.
- Compatible with Ø 100, 125 and 150 mm air ducts.

### Design

- Modern design and aesthetic look.
- The casing and the impeller are made of high-quality durable ABS plastic, UV resistant.
- The intellectual impeller design makes the fan efficiency high and the service life long.
- A 2 W LED lamp is integrated into the fan casing.
- Protection rating IP 24.

### Motor

- Reliable and low-watt electric motor.
- Designed for continuous operation and requires no maintenance.
- Equipped with overheating protection.

### Modifications and Options

**X star alumat** – fan with a matt gray painted front plate.



**X star K** – fan is equipped with a backdraft damper for back flow preventing.



**X star L** – the motor is equipped with ball bearings for long service life (appr. 40 thousand hours) and fan mounting at any angle. The bearings are maintenance-free and contain enough grease for the entire operating period.



**X star turbo** – high-powered motor.



**X star 12** – modification with low-voltage motor. 12 V AC power supply.

### Control

#### Manual:

- The fan is controlled by a room light switch. It is not included in the delivery package.
- Speed control is possible through a thyristor speed controller (see Electrical Accessories). Several fans may be connected to the same regulator unit.

#### Automatic:

- By the electronic control unit **BU-1-60** (see Electrical Accessories). The control unit is supplied separately.

### Mounting features

- The fan is mounted directly into the ventilation shaft.
- Flexible duct application is recommended in case of remote location of the ventilation shaft. The air duct is connected to the fan exhaust flange through a clamp.
- Fixed to wall by self-tapping screws.
- Suitable for ceiling mounting.
- Both parallel or separate switching of the fan and the built-in lamp (refer wiring diagrams).
- For 12 V low-voltage motor fan connection to 220 V / 50 Hz power mains use the step-down transformer TRF 220/12-25 that is available upon separate order.



Vents X star alumat



LED lamp, 2 W

### Accessories



Air ducts

Grilles and hoods

Backdraft damper

Speed controllers

Clamps

### Aerodynamic characteristics

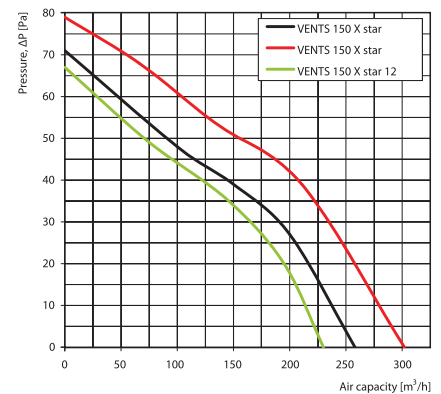
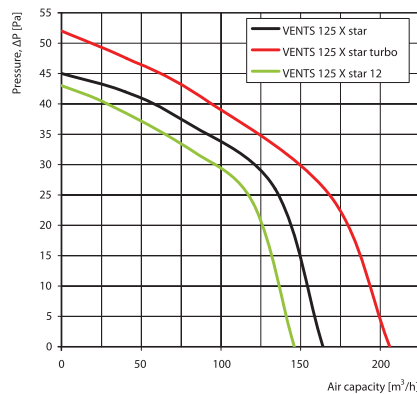
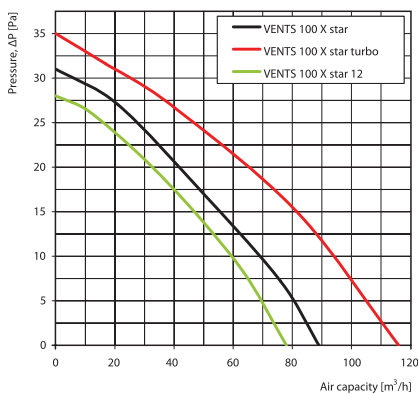

### Technical data

Model	Voltage [V] at 50 Hz	Power Consumption [W]	Current [A]	r.p.m.	Maximum air capacity [m³/h]	Sound Pressure Level at 3 m [dB(A)]	Weight [kg]
VENTS 100 X star	220-240	14	0,085	2300	89	33	0,61
VENTS 125 X star	220-240	16	0,1	2400	164	34	0,75
VENTS 150 X star	220-240	24	0,13	2400	258	37	0,94
VENTS 100 X star turbo	220-240	16	0,1	2300	116	36	0,69
VENTS 125 X star turbo	220-240	24	0,105	2400	206	36	0,83
VENTS 150 X star turbo	220-240	30	0,13	2400	302	39	1,08
VENTS 100 X star 12	12	14	1,5	2200	78	32	0,60
VENTS 125 X star 12	12	16	1,7	2300	146	33	0,73
VENTS 150 X star 12	12	24	2	2300	230	36	0,90

### Mounting example



### Overall dimensions

Model	Dimensions [mm]				
	Ø D	B	H	L	L1
VENTS 100 X star	100	152	120	131	36
VENTS 125 X star	125	177	140	143	42
VENTS 150 X star	150	205	165	160	42

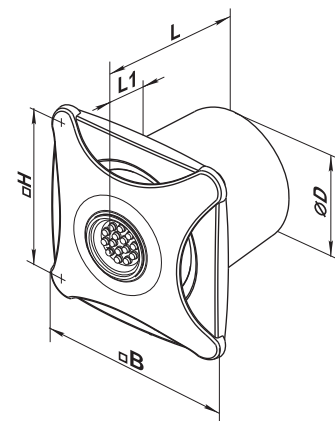

### Certificates



The fans meet the applicable safety and electromagnetic compatibility standards.

# AXIAL WINDOW FANS

## ▶ VENTS MAO1 and VENTS MAO1 reverse Series



Axial window fan with automatic louver shutters for exhaust ventilation with the capacity up to 345 m<sup>3</sup>/h.

Axial window reverse fan with automatic louver shutters for exhaust ventilation with the capacity up to 202 m<sup>3</sup>/h.

## ▶ VENTS MAO2 Series



Axial window fan with automatic louver shutters for exhaust ventilation with the capacity up to 232 m<sup>3</sup>/h. The fan is equipped with an external hood.

## ▶ VENTS M1OK2 Series



Axial window fan with a backdraft damper for exhaust ventilation with the capacity up to 232 m<sup>3</sup>/h. The fan is equipped with an external hood.

## ▶ VENTS VV Series



Axial window fan with automatic louver shutters for exhaust ventilation with the capacity up to 455 m<sup>3</sup>/h. Flange mounting sizes 180 mm and 230 mm.

## ▶ VENTS VVR Series



Axial window fan with automatic louver shutters and reversing motor for exhaust or supply ventilation with the capacity up to 455 m<sup>3</sup>/h. Flange mounting sizes 180 mm and 230 mm.



**Axial window fans  
VENTS MAO1 Series**

Air capacity up to 345 m<sup>3</sup>/h

page  
96



**Axial window fans  
VENTS MAO2 Series**

Air capacity up to 232 m<sup>3</sup>/h

page  
96



**Axial window reverse fans  
VENTS MAO1 reverse**

Air capacity up to 202 m<sup>3</sup>/h

page  
98



**Axial window fans  
VENTS M1OK2 Series**

Air capacity up to 232 m<sup>3</sup>/h

page  
100



**Axial window fans  
VENTS VV Series**

Air capacity up to 455 m<sup>3</sup>/h

page  
102



**Axial window fans  
VENTS VVR Series**

Air capacity up to 455 m<sup>3</sup>/h

page  
102



## VENTS MAO1 Series



Axial window fans for exhaust ventilation with the capacity up to 345 m<sup>3</sup>/h

## VENTS MAO2 Series



Axial window fans for exhaust ventilation with the capacity up to 232 m<sup>3</sup>/h

### Applications

- Continuous or periodic exhaust ventilation of bathroom, showers, kitchens and other utility spaces.
- For mounting in windows.

### Design

- Modern design and aesthetic look.
- The casing and the impeller are made of high-quality durable ABS plastic, UV resistant.
- The intellectual impeller design makes the fan efficiency high and the service life long.
- The fan and motor are specially designed for silent operation.
- Fan is equipped with a thermal actuator that provides smooth opening and shutting of automatic louver shutters for air back flow preventing.
- MAO2 Series fans are equipped with an external hood.
- Protection rating IP 24.

### Motor

- Reliable and low-watt electric motor.
- Designed for continuous operation and requires no maintenance.
- Equipped with overheating protection.

### Modifications and Options



**MAO1 L / MAO2 L** – the motor is equipped with ball bearings for long service life (appr. 40 thousand hours) and fan mounting at any angle. The bearings are maintenance-free and contain enough grease for the entire operating period.



**MAO1 turbo / MAO2 turbo** – high-powered motor.



**MAO1 12 / MAO2 12** – modification with low-voltage motor. 12 V AC power supply.



**MAO1 T / MAO2 T** – equipped with a regulated timer with the operating time from 2 to 30 minutes.



**MAO1 V / MAO2 V** – equipped with a pull cord switch.



**MAO1 VT / MAO2 VT** – equipped with a pull cord switch and a regulated timer with the operating time adjustable from 2 to 30 minutes.

### Control

#### Manual:

- The fan is controlled by a room light switch. It is not included in the delivery package.
- The fan is controlled by the built-in pull cord switch **V**.
- Speed control is possible through a thyristor speed controller (see Electrical Accessories). Several fans may be connected to the same regulator unit.

#### Automatic:

- By the electronic control unit **BU-1-60** (see Electrical Accessories). The control unit is supplied separately.
- By the timer **T** (the built-in run-out timer enables the fan operation within 2 to 30 minutes after the fan switching off).

### Mounting features

- The fan is mounted directly into the window opening.
- For 12 V low-voltage motor fan connection to 220 V / 50 Hz power mains use the step-down transformer TRF 220/12-25 that is available upon separate order.



Back side of MAO2 fan



Fan OFF - louver shutters CLOSED



Fan ON - louver shutters OPEN

### Accessories

#### Speed controllers



### Aerodynamic characteristics

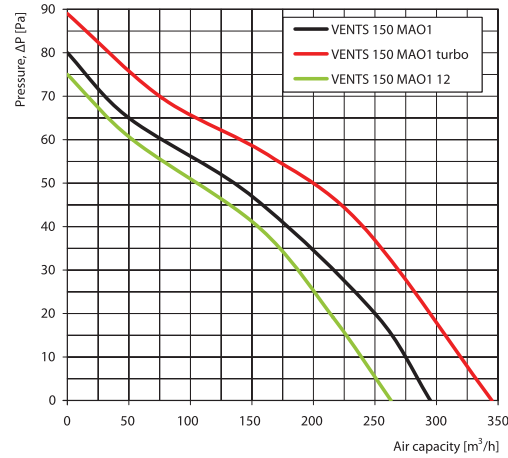
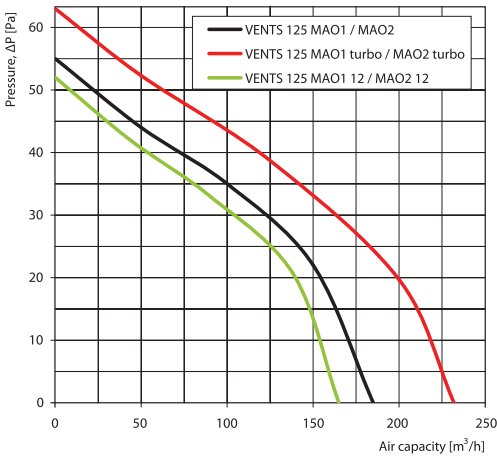

### Technical data

Model	Voltage [V] at 50 Hz	Power Consumption [W]	Current [A]	r.p.m.	Maximum air capacity [m³/h]	Sound Pressure Level at 3 m [dB(A)]	Weight [kg]
VENTS 125 MAO1	220-240	22	0,1	2400	185	35	1,15
VENTS 150 MAO1	220-240	26	0,13	2400	295	41	1,53
VENTS 125 MAO1 turbo	220-240	24	0,105	2400	232	37	1,31
VENTS 150 MAO1 turbo	220-240	30	0,13	2400	345	43	1,67
VENTS 125 MAO1 12	12	16	1,7	2300	165	34	1,13
VENTS 150 MAO1 12	12	24	2	2300	263	40	1,49
VENTS 125 MAO2	220-240	22	0,1	2400	185	35	1,14
VENTS 125 MAO2 turbo	220-240	24	0,105	2400	232	37	1,24
VENTS 125 MAO2 12	12	16	1,7	2300	165	34	1,12

### Overall dimensions

Model	Dimensions [mm]					
	Ø D	B	H	H1	L1	L2
VENTS 125 MAO1	125	190	173	—	58	53
VENTS 150 MAO1	150	212	195	—	66	60
VENTS 125 MAO2	—	190	173	160	58	123

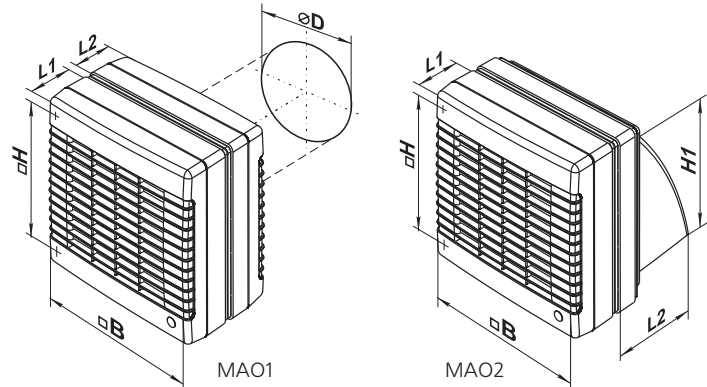

### Mounting examples

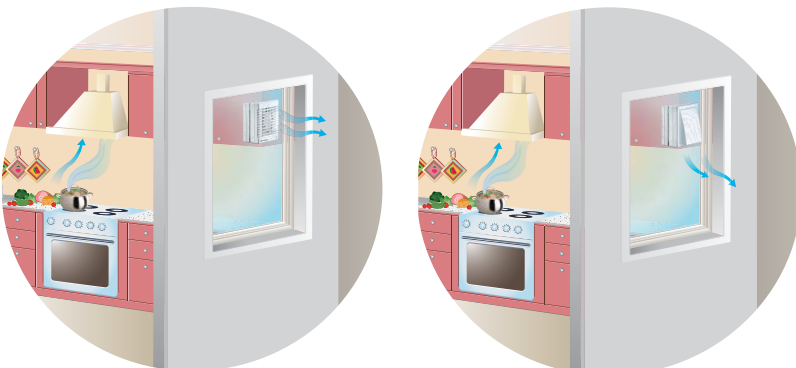

### Certificates



The fans meet the applicable safety and electromagnetic compatibility standards.

## VENTS MAO1 reverse Series



Axial window two-speed reverse fans for exhaust and supply ventilation with the capacity up to 202 m<sup>3</sup>/h

### Application

- Permanent or periodic exhaust and supply ventilation of kitchens, garages, workshops and residential premises.
- For mounting in windows.

### Design

- Modern design and aesthetic look.
- The casing and the impeller are made of high-quality durable ABS plastic, UV resistant.
- The intellectual impeller design makes the fan efficiency high and the service life long.
- The fan and motor are specially designed for silent operation.
- Fan is equipped with a thermal actuator that provides smooth opening and shutting of automatic louver shutters for air back flow preventing.
- Supplied with a three bottom control unit and 220 V - 12 V transformer.
- Transformer provides reliable fan operation with safe power supply 12 V.
- Protection rating IP 24.

### Motor

- Reliable DC motor (12V) with low energy demand.
- Two-speed reverse DC motor provides fan operation both in supply and exhaust mode.
- Special motor design ensures low noise level.
- Designed for continuous operation and required no maintenance.
- Equipped with overload protection.

### Control

#### Manual control:

- Three bottom control unit (included into delivery set) with integrated circuit board is used for:

1. On/off switching;
2. Fan speed switching on/off (min - max);
3. Fan operation mode switching (exhaust mode - supply mode).

### Mounting features

- Fan is installed directly into window opening.



Fan off - louver shutters CLOSED



Control unit



Exhaust mode



2 speed



on



Supply mode



1 speed



off



Fan on - louver shutters OPEN

### Aerodynamic characteristics

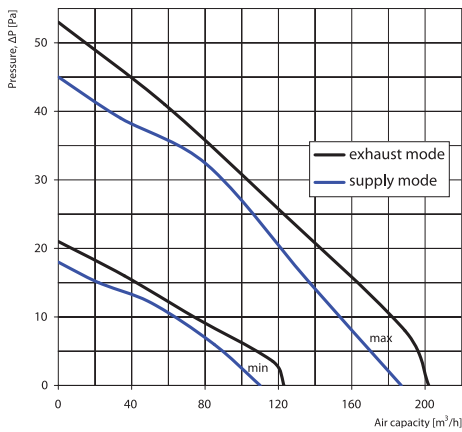

### Technical Data

Model	Mode	Speed	Voltage [V] at 50 Hz	Power Consumption [W]	Current [A]	RPM [min <sup>-1</sup> ]	Maximum air capacity [m <sup>3</sup> /h]	Sound Pressure Level at 3 m [dB(A)]	Weight [kg]
VENTS 150 MAO1 reverse	exhaust	max	220-240	8,7	0,045	1950	202	33	1,53
		min		5,2	0,025	1215	123	28	
	supply	max		7,6	0,045	2030	187	32	
		min		5,1	0,025	1210	110	26	

### Overall dimensions

Model	Dimensions [mm]					
	Ø D	B	H	H1	L1	L2
VENTS 150 MAO1 reverse	150	212	195	—	66	60

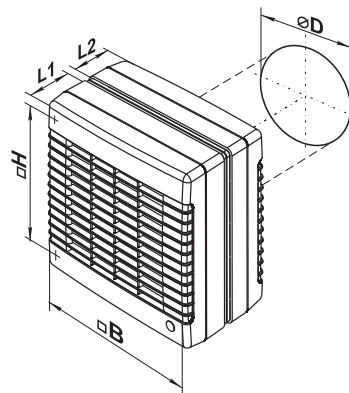

### Mounting examples

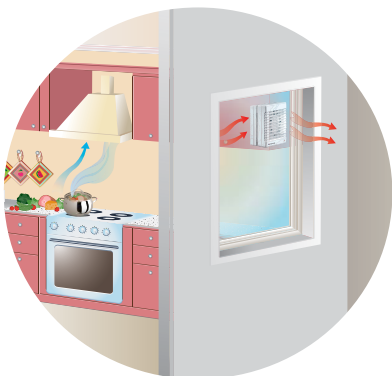

Fan operation in EXHAUST mode

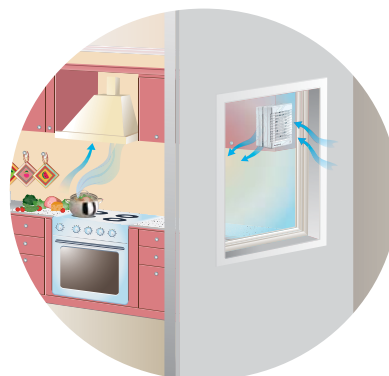

Fan operation in reverse SUPPLY-EXHAUST mode

### Certificates



The fans meet the applicable safety and electromagnetic compatibility standards.

## VENTS M1OK2 Series



Axial window fans for exhaust ventilation with the capacity up to 232 m<sup>3</sup>/h

### Applications

- Continuous or periodic exhaust ventilation of bathroom, showers, kitchens and other utility spaces.
- For mounting in windows.



Back side of M1OK2 fan

### Design

- Modern design and aesthetic look.
- The casing and the impeller are made of high-quality durable ABS plastic, UV resistant.
- The intellectual impeller design makes the fan efficiency high and the service life long.
- The fan and motor are specially designed for silent operation.
- Fan is equipped with a backdraft damper for back flow preventing.
- The fan is equipped with an external hood.
- Protection rating IP 24.

### Motor

- Reliable and low-watt electric motor.
- Designed for continuous operation and requires no maintenance.
- Equipped with overheating protection.

### Modifications and Options



**M1OK2 L** – the motor is equipped with ball bearings for long service life (appr. 40 thousand hours) and fan mounting at any angle. The bearings are maintenance-free and contain enough grease for the entire operating period.



**M1OK2 turbo** – high-powered motor.



**M1OK2 12** – modification with low-voltage motor. 12 V AC power supply.



**M1OK2 T** – equipped with a regulated timer with the operating time from 2 to 30 minutes.



**M1OK2 V** – equipped with a pull cord switch.



**M1OK2 VT** – equipped with a pull cord switch and a regulated timer with the operating time adjustable from 2 to 30 minutes.

### Control

#### Manual:

- The fan is controlled by a room light switch. It is not included in the delivery package.
- The fan is controlled by the built-in pull cord switch **V**.

- Speed control is possible through a thyristor speed controller (see Electrical Accessories). Several fans may be connected to the same regulator unit.

#### Automatic:

- By the electronic control unit **BU-1-60** (see Electrical Accessories). The control unit is supplied separately.

- By the timer **T** (the built-in run-out timer enables the fan operation within 2 to 30 minutes after the fan switching off).

### Mounting features

- The fan is mounted directly into the window opening.

- For 12 V low-voltage motor fan connection to 220 V / 50 Hz power mains use the step-down transformer TRF 220/12-25 that is available upon separate order.

## Accessories

### Speed controllers



### Aerodynamic characteristics

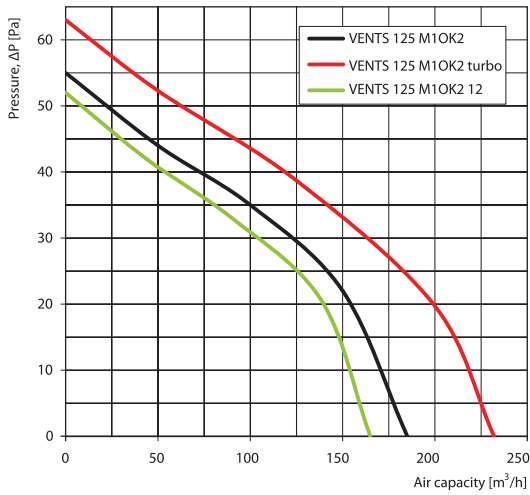

### Technical data

Model	Voltage [V] at 50 Hz	Power Consumption [W]	Current [A]	r.p.m.	Maximum air capacity [m³/h]	Sound Pressure Level at 3 m [dB(A)]	Weight [kg]
VENTS 125 M1OK2	220-240	22	0,1	2400	185	35	1,15
VENTS 125 M1OK2 turbo	220-240	24	0,105	2400	232	37	1,31
VENTS 125 M1OK2 12	12	16	1,7	2300	165	34	1,13

### Mounting example

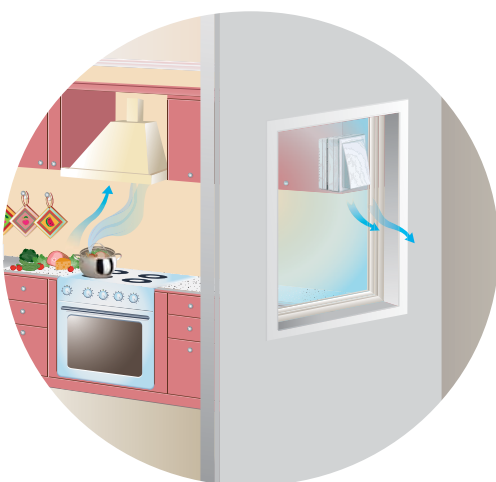

### Overall dimensions

Model	Dimensions [mm]					
	Ø D	B	H	H1	L1	L2
VENTS 125 M1OK2	—	190	173	160	58	123

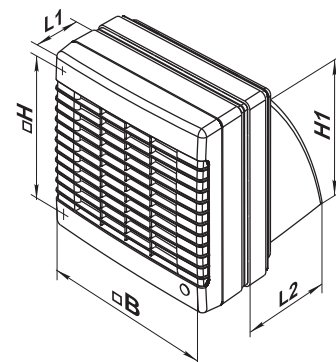

### Certificates

The fans meet the applicable safety and electromagnetic compatibility standards.

## VENTS WV Series



Axial window fan with automatic louver shutters for exhaust ventilation with the capacity up to 455 m<sup>3</sup>/h

## VENTS VVR Series



Axial window fan with automatic louver shutters and reversing motor for exhaust and supply ventilation with the capacity up to 455 m<sup>3</sup>/h

### Applications

- Continuous or periodic exhaust ventilation of bathroom, showers, kitchens and other utility spaces.
- For mounting in windows.

### Design

- Modern design and aesthetic look.
- The casing and the impeller are made of high-quality durable ABS plastic, UV resistant.
- The intellectual impeller design makes the fan efficiency high and the service life long.
- The fan and motor are specially designed for silent operation.
- Equipped with automatic louver shutter for air back flow prevention.
- Protection rating IP 24.

### Motor

- Reliable and low-watt electric motor.
- Designed for continuous operation and requires no maintenance.
- Equipped with overheating protection.
- **VVR** series fans are equipped with a reversing motor for combination of air exhaust and air supply functions.

### Control

#### Manual:

- The fan is controlled by a room light switch. It is not included in the delivery package.
- Speed control is possible through a thyristor speed controller (see Electrical Accessories). Several fans may be connected to the same regulator unit.

#### Automatic:

- By the electronic control unit BU-1-60 (see Electrical Accessories). The control unit is supplied separately.

### Mounting features

- The fan is mounted directly into the window opening.



Fan ON - louver shutters OPEN



Fan OFF - louver shutters CLOSED

## Accessories

Speed controllers



### Aerodynamic characteristics

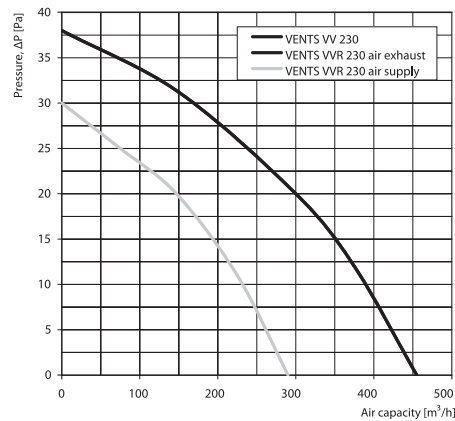
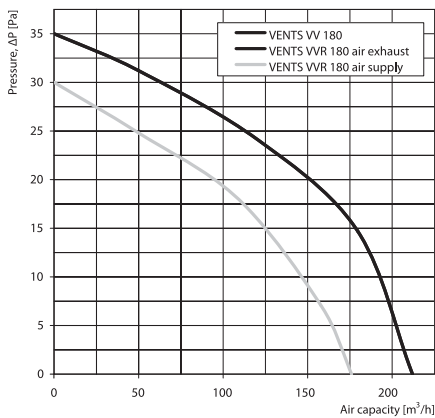

### Technical data

Model		Voltage [V] at 50 Hz	Power Consumption [W]	Current [A]	r.p.m.	Maximum air capacity [m³/h]	Sound Pressure Level at 3 m [dB(A)]	Weight [kg]
VENTS VV 180	air exhaust	220-240	25	0,10	1400	212	31	1,6
VENTS VVR 180	air exhaust	220-240	25	0,10	1400	212	31	1,6
	air supply					176	31	
VENTS VV 230	air exhaust	220-240	30	0,13	1300	455	32	2,2
VENTS VVR 230	air exhaust	220-240	30	0,13	1300	455	32	2,2
	air supply					290	32	

### Mounting example



### Overall dimensions

Model	Dimensions [mm]			
	A	B	C	D
VENTS VV 180	230	65	87	177
VENTS VVR 180	230	65	87	177
VENTS VV 230	295	74	85	237
VENTS VV 230	295	74	85	237

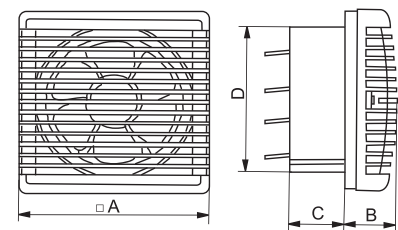

### Certificates



The fans meet the applicable safety and electromagnetic compatibility standards.





# CENTRIFUGAL FANS

## ▶ VENTS CF Series



Centrifugal single-speed fans with a built-in filter for exhaust ventilation with the air capacity of up to 122 m<sup>3</sup>/h. Compatible with Ø100 mm air ducts.

## ▶ VENTS CF3 Series



Centrifugal three-speed fans with a built-in filter for exhaust ventilation with the air capacity of up to 90 m<sup>3</sup>/h. Equipped with a three speed switch. Compatible with Ø100 mm air ducts.



**Centrifugal fans  
VENTS CF Series**

Air capacity up to 122 m<sup>3</sup>/h

page  
106



**Centrifugal fans  
VENTS CF3 Series**

Air capacity up to 90 m<sup>3</sup>/h

page  
108

## VENTS CF Series



Centrifugal fans for exhaust ventilation with the capacity up to 122 m<sup>3</sup>/h

### Applications

- Continuous or periodic exhaust ventilation of bathroom, showers, kitchens and other utility spaces.
- Ventilation shaft mounting or duct connection.
- Designed for high-resistance ventilation duct systems.
- Compatible with Ø 100 mm air ducts.

### Design

- Modern design and aesthetic look.
- The casing and the impeller are made of high-quality durable ABS plastic, UV resistant.
- The easy to use removable grille with a filter element protects the fan internal components against grease and dust penetration and makes it suitable for kitchen exhaust ventilation.
- The basic CF fan modification includes a dust filter. Aluminium grease filter configurations are also available (CFA model).
- The centrifugal fan impeller has forward-curved blades for high pressure and low noise levels.
- The centrifugal fan impeller has forward-curved blades for high pressure and low noise levels.
- Protection rating IP 24.

### Motor

- Reliable and low-watt single-phase electric motor.
- The basic motor modification includes plain bearings.
- The „turbo“ modification includes the motor equipped with ball bearings mounted on specially designed vibration dampers.
- Designed for continuous operation and requires no maintenance.
- Equipped with overheating protection.

### Modifications and Options

CFA – fan with an aluminium grease filter.



**CF 100 turbo** – high-powered motor. The motor is equipped with ball bearings for long service life (appr. 40 thousand hours) and mounted on specially designed vibration mounting. The bearings are maintenance-free and contain enough grease for the entire operating period.



**CF 100 T** – equipped with a regulated timer with the operating time from 2 to 30 minutes.



**CF 100 TH** – equipped with a timer with the operating time from 2 to 30 minutes and a humidity sensor with the threshold value from 60 to 90%.



**CF 100 V** – equipped with a pull cord switch.



**CF 100 VT** – equipped with a pull cord switch and a regulated timer with the operating time adjustable from 2 to 30 minutes.



**CF 100 VTH** – equipped with a pull cord switch, regulated timer with the operating time adjustable from 2 to 30 minutes and a humidity sensor with the operating threshold range from 60% to 90%.



**CF 100 TP** – equipped with a regulated timer and a motion sensor with the sensitivity area from 1 to 4 m and the detection angle up to 100°.



**CF 100 12** – modification with low-voltage motor. 12 V AC power supply.

### Control

#### Manual:

- The fan is controlled by a room light switch. It is not included in the delivery package.
- The fan is controlled by the built-in pull cord switch **V**. Not applied in case of ceiling mounting.
- Speed control is possible through a thyristor speed controller (see Electrical Accessories). Several fans may be connected to the same regulator unit.

#### Automatic:

- By the electronic control unit **BU-1-60** (see Electrical Accessories). The control unit is supplied separately.

### Mounting features

- Suitable for external or built-in mounting.
- Flexible duct application is recommended in case of remote location of the ventilation shaft. The air duct is connected to the fan exhaust flange through a clamp.
- Fixed to wall by self-tapping screws or fixing brackets.
- Suitable for ceiling mounting.
- For 12 V low-voltage motor fan connection to 220 V / 50 Hz power mains use the step-down transformer TRF 220/12-25 that is available upon separate order.

### Accessories

Air ducts



Grilles and hoods



Speed controllers



Clamps



Replaceable filters



### Aerodynamic characteristics

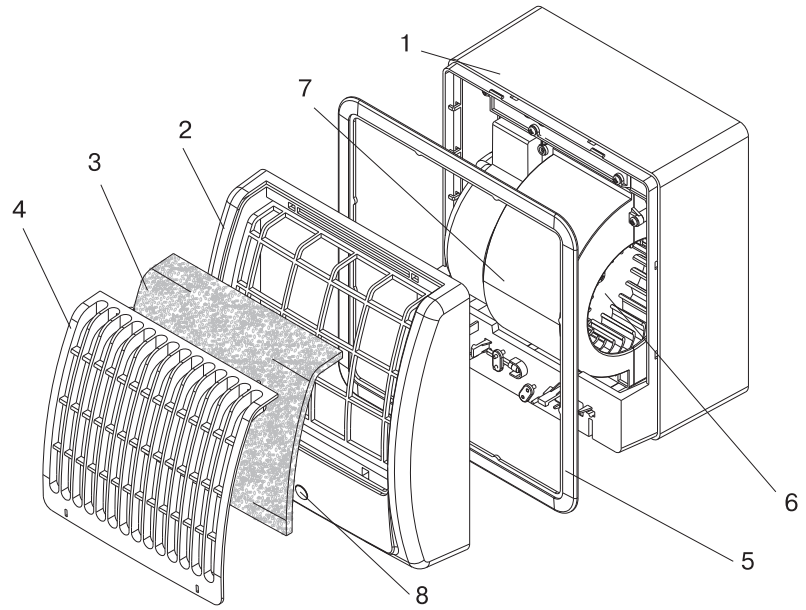
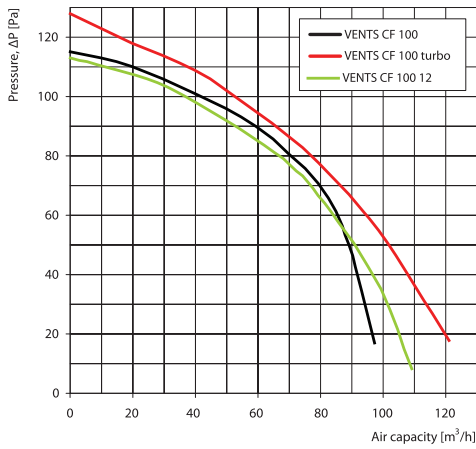

- 1. Casing
- 2. Removable cover
- 3. Filter
- 4. Grille
- 5. Decorative frame
- 6. Impeller
- 7. Scroll casing
- 8. Light indicator

### Technical data

Model	Voltage [V] at 50 Hz	Power Consumption [W]	Current [A]	r.p.m.	Maximum air capacity [m³/h]	Sound Pressure Level at 3 m [dB(A)]	Weight [kg]
VENTS CF 100	220-240	16	0,12	2250	98	36	1,20
VENTS CF 100 turbo	220-240	29	0,170	2500	122	38	1,30
VENTS CF 100 12	12	24	3,00	2300	110	37	1,2

### Mounting examples



Wall surface mounting



Wall flush mounting

### Overall dimensions

Model	Dimensions [mm]						
	∅ D	B	H	L	L1	L2	L3
VENTS CF 100	100	180	195	132	59	73	26

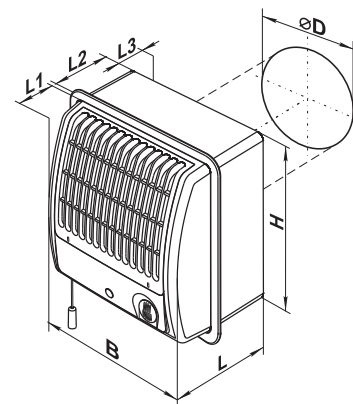

### Certificates



The fans meet the applicable safety and electromagnetic compatibility standards.

## VENTS CF3 Series



Centrifugal fans for exhaust ventilation with the capacity up to 90 m<sup>3</sup>/h

### Applications

- Continuous or periodic exhaust ventilation of bathroom, showers, kitchens and other utility spaces.
- Ventilation shaft mounting or duct connection.
- Designed for high-resistance ventilation duct systems.
- Compatible with Ø100 mm air ducts.

### Design

- Modern design and aesthetic look.
- The casing and the impeller are made of high-quality durable ABS plastic, UV resistant.
- The easy to use removable grille with a filter element protects the fan internal components against grease and dust penetration and makes it suitable for kitchen exhaust ventilation.
- The basic CF3 fan modification includes a dust filter. Aluminium grease filter configurations are also available (CFA3 model).
- The centrifugal fan impeller has forward-curved blades for high pressure and low noise levels.
- Equipped with a gravitational backdraft damper for air back flow prevention.
- Protection rating IP 24.

### Motor

- Reliable and low-watt single-phase three-speed electric motor.
- Motor equipped with ball bearings mounted on specially designed vibration dampers.
- Designed for continuous operation and requires no maintenance.
- Equipped with overheating protection.

### Modifications and Options

- CFA3** – fan with an aluminium grease filter
- CF3 P3** – fan with a three speed switch.

### Control

#### Manual:

- The fan is controlled by the speed switch P3-1-300 delivered as a standard (**CF3 P3** model).

#### Automatic:

- By the electronic control unit **BU-1-60** (see Electrical Accessories). The control unit is supplied separately.

### Mounting features

- Suitable for external or built-in mounting.
- Flexible duct application is recommended in case of remote location of the ventilation shaft. The air duct is connected to the fan exhaust flange through a clamp.
- Fixed to wall by self-tapping screws or fixing brackets.
- Suitable for ceiling mounting.

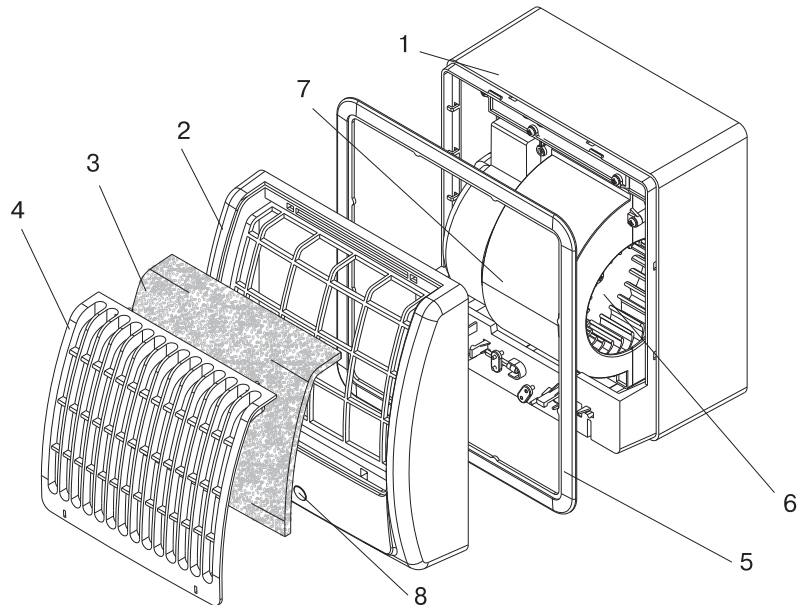

- |                    |           |                     |                    |
|--------------------|-----------|---------------------|--------------------|
| 1. Casing          | 3. Filter | 5. Decorative frame | 7. Scroll casing   |
| 2. Removable cover | 4. Grille | 6. Impeller         | 8. Light indicator |

### Accessories



Air ducts

Grilles and hoods

Speed controllers

Clamps

Replaceable filters

### Aerodynamic characteristics

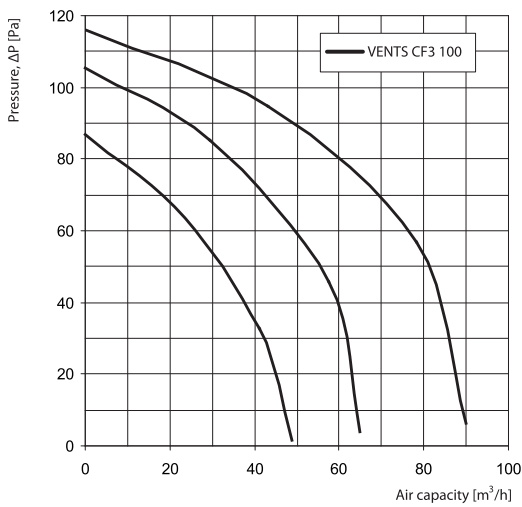

### Overall dimensions

Model	Dimensions [mm]						
	Ø D	B	H	L	L1	L2	L3
VENTS CF3 100	100	180	195	132	59	73	26

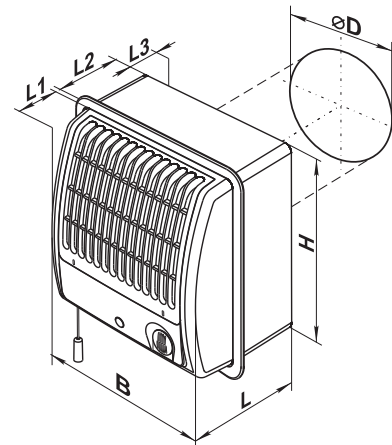

### Technical data

Model	Voltage [V] at 50 Hz	Power Consumption [W]	Current [A]	r.p.m.	Maximum air capacity [m³/h]	Sound Pressure Level at 3 m [dB(A)]	Weight [kg]
VENTS CF3 100	1 speed	220-240	13	0,08	825	48	25
	2 speed	220-240	17	0,11	1010	65	31
	3 speed	220-240	27	0,16	1593	90	34

### Mounting examples



Wall surface mounting



Wall flush mounting

### Certificates



The fans meet the applicable safety and electromagnetic compatibility standards.

## ■ Various mounting options for various design features

### ● VKO and VKO1 Series

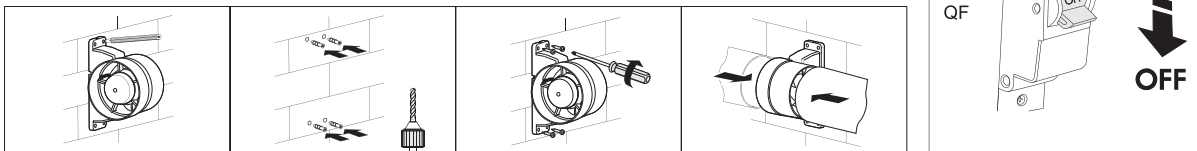

### ● K, K1, PF, PF1, F and F1 Series

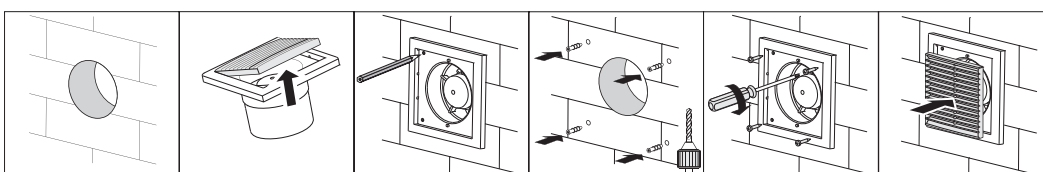

### ● M, M3, MA and MA1 Series

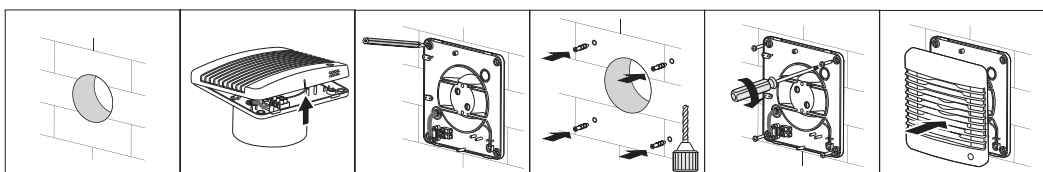

### ● D, LD, S, X, X1, X Star Series

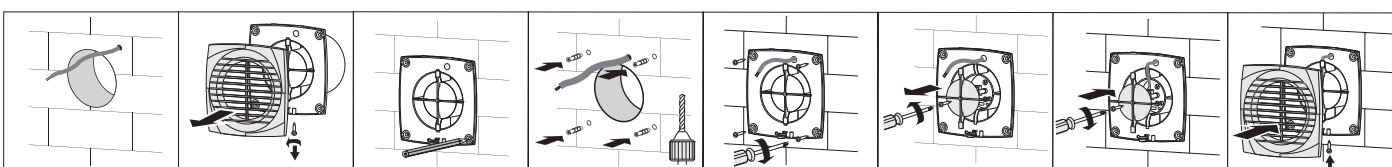

### ● MAO Series

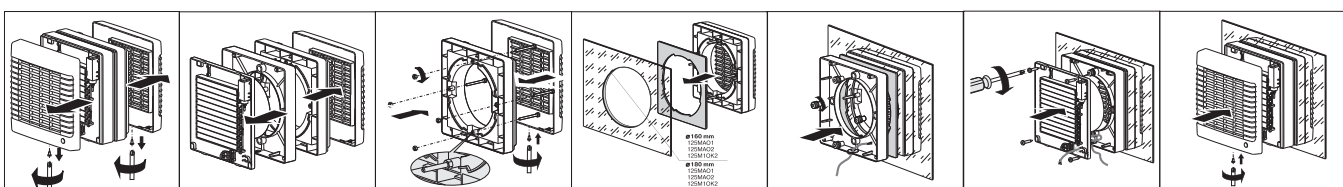

### ● CF Series

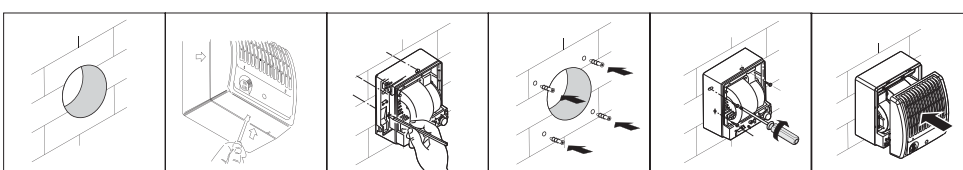

## ■ Control of built-in fan functions

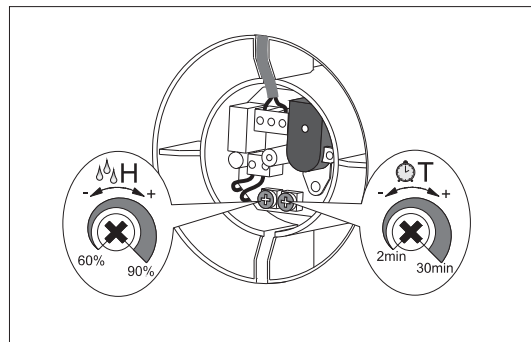
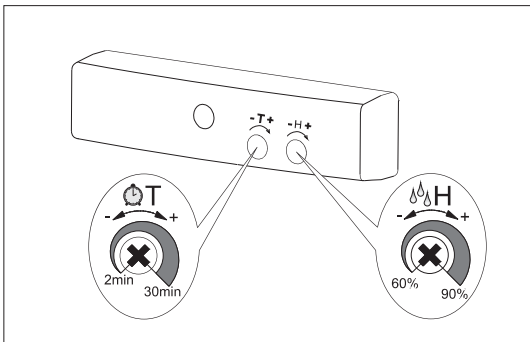

- Humidity sensor threshold value is adjusted with potentiometer **H** by turning its control knob clockwise to increase or counter-clockwise to decrease the humidity threshold value.

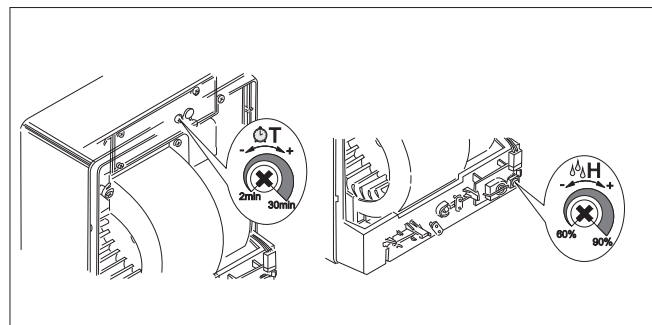
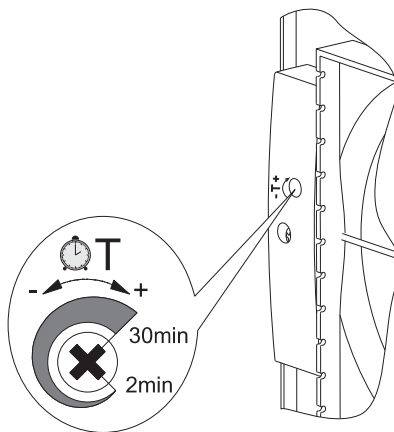
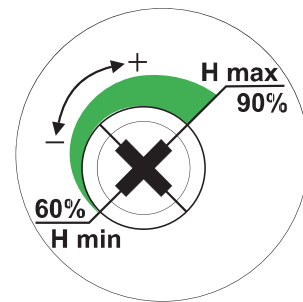

## ■ Fan maintenance and cleaning

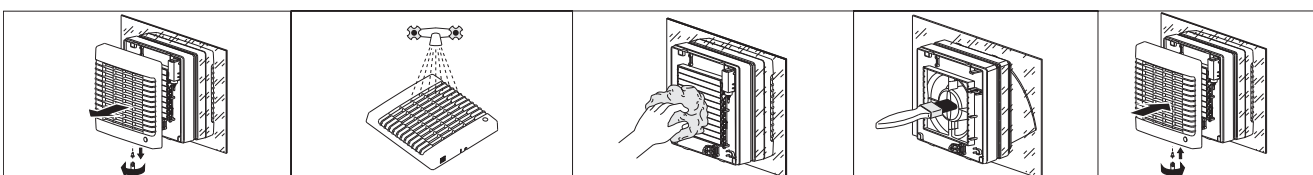
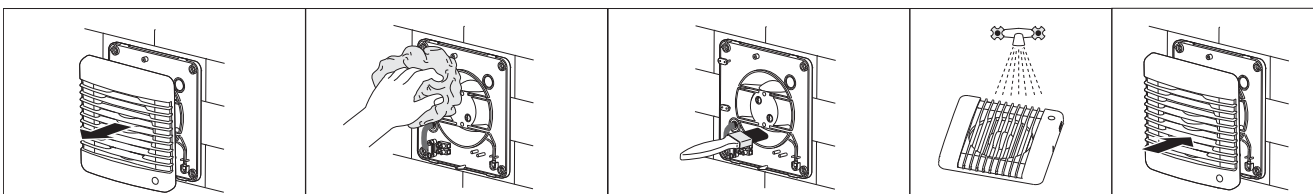



**Wall surface mounting**



Direct air exhaust through the wall

**Ceiling mounting**



Exhaust ventilation through the ceiling and wall

**Wall surface mounting**

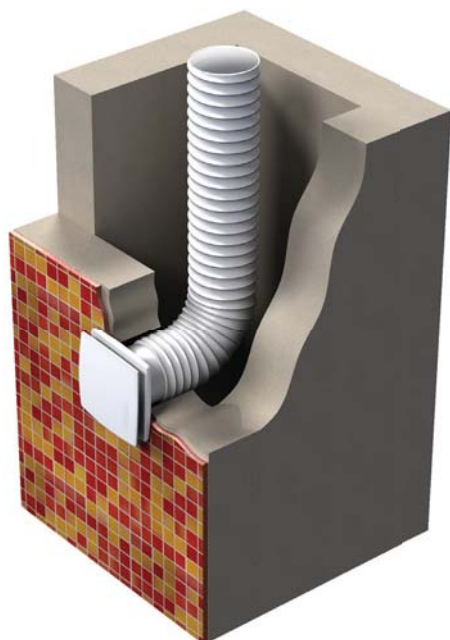

Air exhaust through the ventilation shaft

**Wall surface mounting**

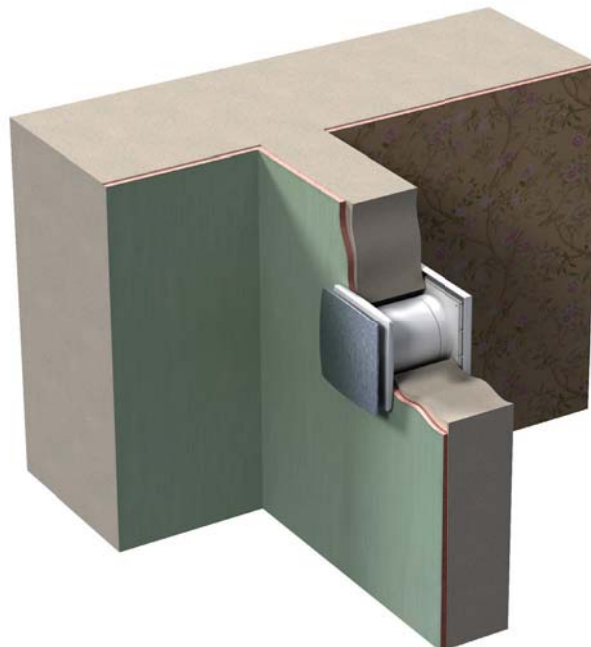

Air exhaust through the wall. For warm air distribution from a room with a fireplace to adjacent premises

**Wiring diagram for the fans equipped with a built-in switch**

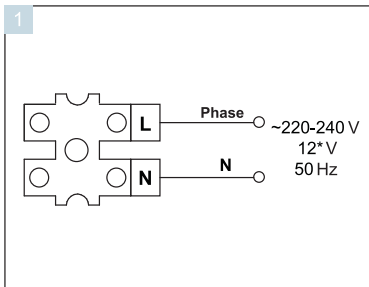

**Wiring diagram for the fans without built-in switch**

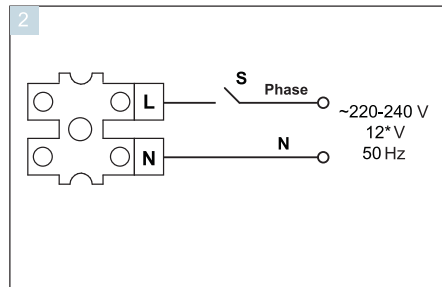

**Wiring diagram for the fans equipped with a timer / timer, humidity sensor and a built-in switch**

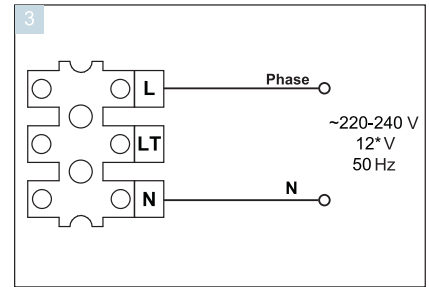

**Wiring diagram for the fans equipped with a timer / timer with a humidity sensor without built-in switch**

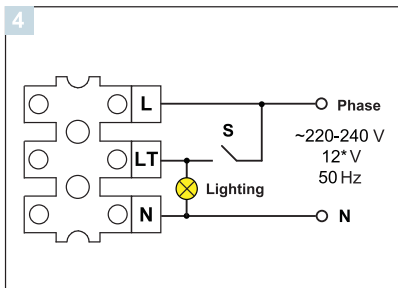

**Wiring diagram for the fans with a light lamp. Separate activation of the fan and the built-in lamp.**

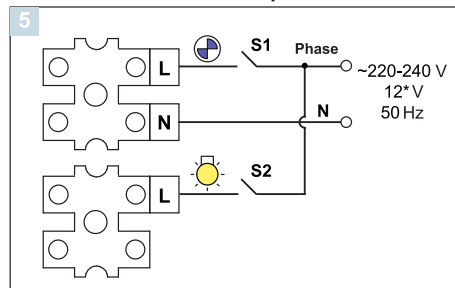

**Wiring diagram for the fans with a light lamp. Parallel activation of the fan and the built-in lamp.**

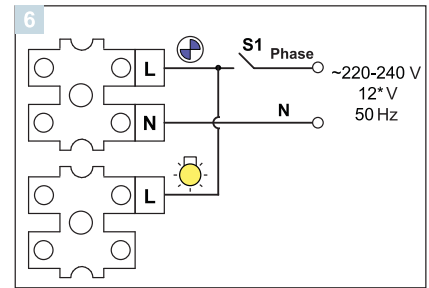

**Wiring diagram for the fans with an light lamp and grounding. Separate activation of the fan and the built-in lamp.**

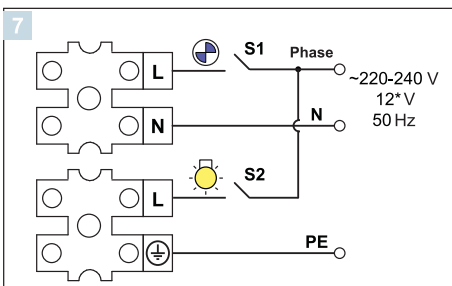

**Wiring diagram for the fans with a light lamp and grounding. Parallel switching of the fan and the built-in lamp.**

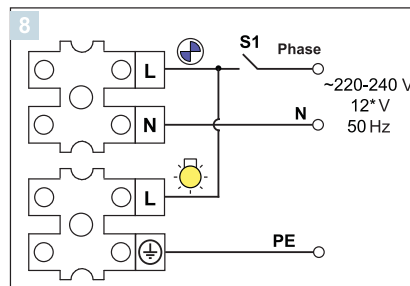

**Wiring diagram for the fans with grounding**

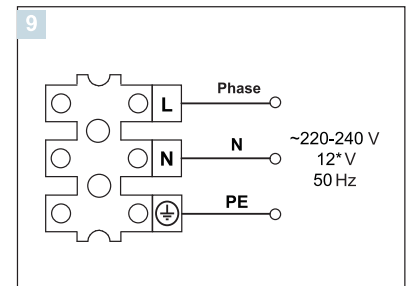

\* - only for fans designed for 12 V rated voltage (specified on the fan casing and packing).

S, S1, S2 - external switches.

## Operating logic of the fans with optional equipment

- The fan equipped with a **timer** is activated by the control voltage supplied to LT input. After the control voltage is disconnected the fan continues operating within the time period within 2 to 30 minutes according to the timer settings. The turn-off delay time is adjusted by turning the respective potentiometer T control knob clockwise to increase and counter-clockwise to reduce it.
- The fan equipped with a **timer and humidity sensor** is activated by the control voltage supplied to LT input or in case of exceeding the preset humidity threshold value adjustable from ~60% to ~90%. After the control voltage is disconnected or as the humidity level H drops below the set threshold the fan continues operating within the time period within 2 to 30 minutes according to the timer settings. The turn-off delay time and the threshold humidity level are adjusted by turning the control knob of the respective potentiometer T for timer and H for humidity sensor clockwise to increase and counter-clockwise to reduce the set value. To set the maximum humidity level (90%) set the potentiometer control knob for H max position.
- The fan equipped with a **timer and motion sensor** is activated in case of the moving detection at the distance from 1 m to 4 m with 100° detection angle. After motion is off the fan continues operating within the time period within 2 to 30 minutes according to the timer settings. The turn-off delay time is adjusted by turning the respective potentiometer T control knob clockwise to increase and counter-clockwise to reduce it.
- Wiring diagram for connection of the light lamp to the fan timer operated by the common switch is shown on diagram 4. Upon the light lamp disconnection the fan continues operating according to the timer setting within the set time period.



# ACCESSORIES

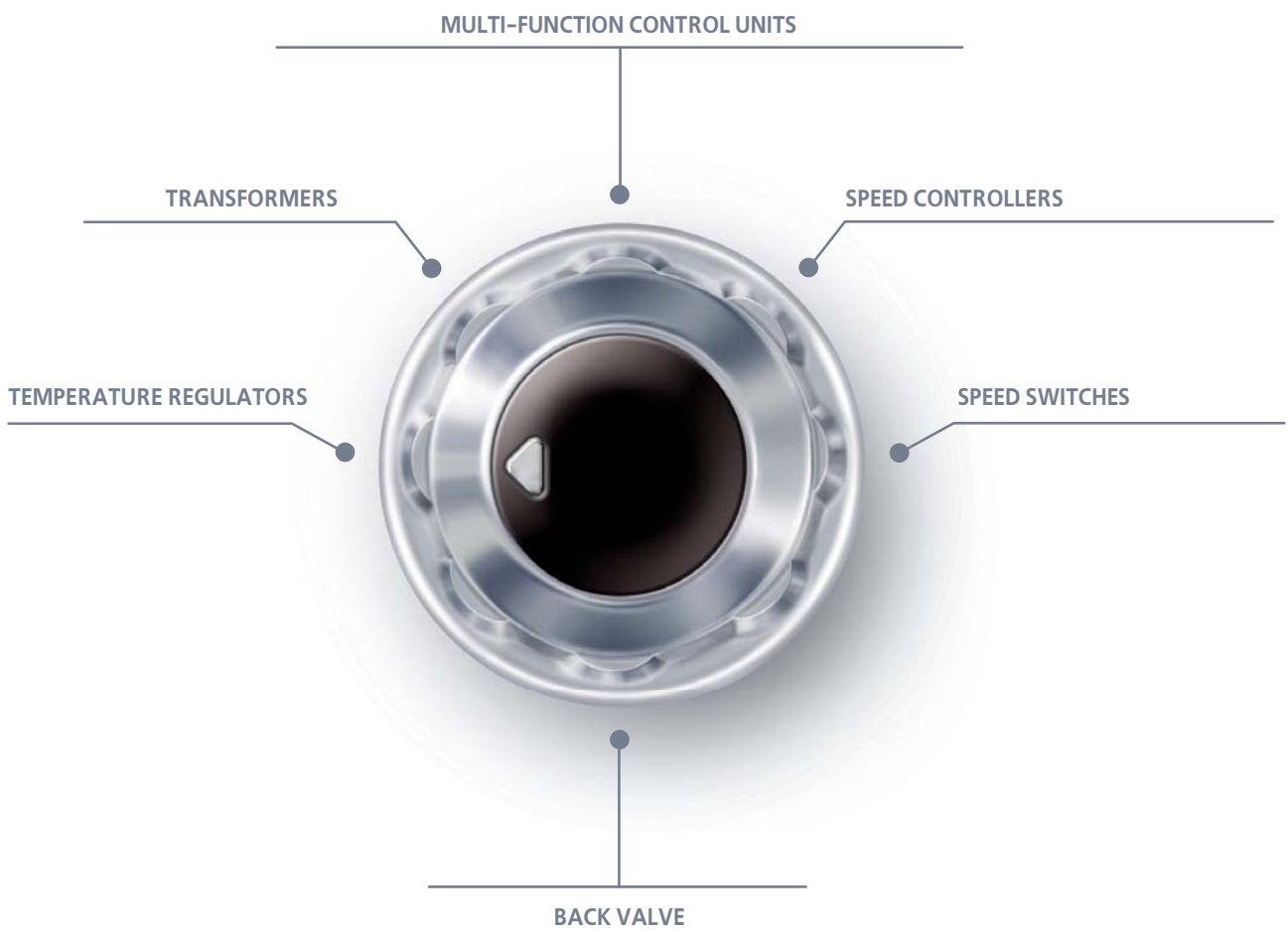



**Control unit**

**page**  
116



**Thyristor speed controllers**

**page**  
117



**Autotransformer speed controller**

**page**  
119



**Speed switches for multiple-speed fans**

**page**  
120



**Temperature regulators**

**page**  
122



**Transformers**

**page**  
124



**Back valve**

**page**  
126

## Control unit BU-1-60

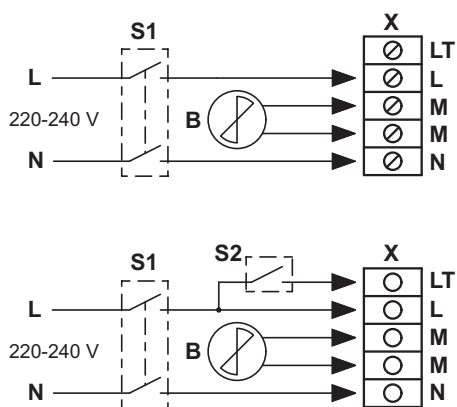
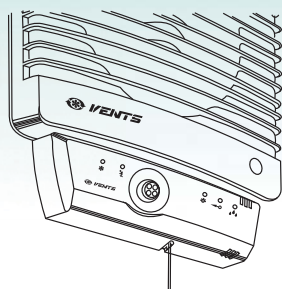

Wiring diagram of the control unit

B - fan;  
S1 - automatic circuit breaker;  
S2 - external switch;  
X - input terminal block BU.

### Application

Automation and control of residential fan operation. It includes automatic controls as timer, humidity sensor, photosensor and motion sensor. All these options can be used in any combination.

### Design

- The control unit casing is made of high-quality plastic.
- The front panel is equipped with light indicators that display the current operating mode.
- Automatic operation with selected mode is possible. The switches are used to activate required operation modes depending on a specific application. The control units are available in several modifications:
- Turn-off delay timer keeps the fan running for a set time period after turning the built-in or external switch off that provides extra ventilation in the premise. The control unit switches the fan off from 5 sec to 30 minutes.
- Cyclic timer operation: the cyclic operation mode allows switching the fan on and off with set time intervals. Operation or standstill duration is adjusted from 5 sec to 30 min. The fan switches on and operates within pre-set time period followed by a pause according to timer settings. After that the cycle is renewed.
- Humidity sensor switches the fan on as the humidity level in the premise increases above the set threshold. As it drops back the control unit switches the fan off. Humidity threshold is user-adjustable.

- Built-in photosensor is sensitive to illumination in the room and switches the fan automatically on.

- «Dark mode»: The control unit switches the fan on after the light is off. The operation duration is adjustable from 5 sec to 30 min and the photosensor threshold is set by the regulator.

- «Light mode»: The control unit switches the fan on after the light is on. As light is off the fan continues operating and turns off as the turn-off delay timer requires from 5 sec to 30 min. If the light is on more than 60 minutes the fan switches off. The photosensor threshold is set by the control unit.

- The motion sensor responds to human motion in the sensitivity area and switches the fan automatically on. When motion is not registered the control unit switches the fan off as the turn-off delay timer requires from 5 sec to 30 min. Use of the motion sensor makes the fan control easy and is especially suitable for periodically visited premises. The sensitivity area is 5 m max. and the detection angle up to 130°.

### Mounting

- The control unit is designed for indoor installation, both close to the fan and remote. The installation place is selected with respect to the furniture location and walking routes.

Model	Options				
	switch	timer	humidity sensor	motion sensor	photosensor
VENTS BU-1-60	●	●	●	●	●
VENTS BU-1-60 TF		●			●
VENTS BU-1-60 THF		●	●		●
VENTS BU-1-60 THPF		●	●	●	●

### Technical data

	BU-1-60
Voltage [V] at 50 Hz	1- 230
Max. load power [W]	60
Maximum load current [A]	0,3
Overall dimensions LxBxH [mm]	151x46x27
Maximum ambient temperature [°C]	+40
Protection	IP 34
Weight [kg]	0,075

### Speed controller RS-1-300

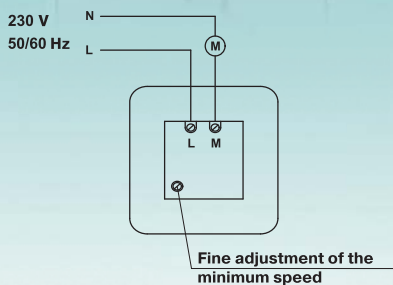

Controller wiring diagram

#### Application

- Used in ventilation systems for switching on/off and speed control of single-phase fan motors with voltage control.
- Several fans can be controlled from the same unit in case the total consumption current does not exceed the permissible controller current value.

#### Design and control

- The casing is made of plastic.
- The controller is featured with high efficiency and control accuracy.
- Turn to maximum speed by rotating the control knob.

- Regulation starts from the minimum to the maximum voltage value. The maximum speed produces the smoothest rotation.
- The minimum speed value is set by a variable resistor located at the controller control panel.

#### Protection

- For overload protection the controller is equipped with a replaceable melting fuse.

#### Mounting

- The controller is designed for indoor installation on the wall inside a flush mounting box.
- Suitable for installation inside the round junction boxes.

#### Technical data

	RS-1-300
Voltage [V] at 50 Hz	1- 230
Rated current [A]	1,5
Overall dimensions LxBxH [mm]	95x85x60
Maximum ambient temperature [°C]	40
Protection	IP 40
Weight [kg]	0,11

### Speed controller RS-1-400

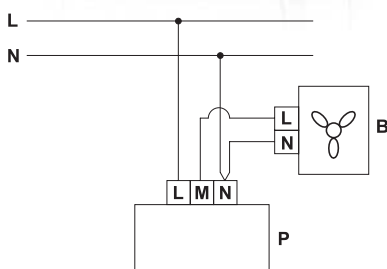

Controller wiring diagram

#### Application

- Used in ventilation systems for switching on/off and speed control of single-phase fan motors with voltage control.
- Several fans can be controlled from the same unit in case the total consumption current does not exceed the permissible controller current value.

#### Design and control

- The casing is made of plastic.
- The controller is featured with high efficiency and control accuracy.
- Turn to maximum speed by rotating the control knob.
- Regulation starts from the minimum to the maximum voltage value. The maximum speed produces the smoothest rotation.

- The minimum speed value is set by a variable resistor located at the controller circuit board.

#### Protection

- The input circuit of the speed controller is equipped with a fuse for overload protection.
- The controller is equipped with a transient filter.

#### Mounting

- The controller is designed for indoor installation on the wall inside a flush junction mounting box.
- Suitable for installation inside a standard junction box.

#### Technical data

	RS-1-400
Voltage 50/60 Hz [V]	1- 230
Rated current [A]	1,8
Overall dimensions LxBxH [mm]	78x78x63
Maximum ambient temperature [°C]	35
Protection	IP 40
Weight [kg]	0,11

## Speed controller RS-...N (V)

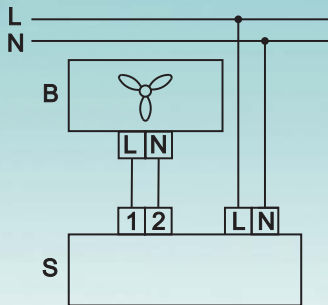

Controller wiring diagram

### Application

- Used in ventilation systems for switching on/off and speed control of single-phase fan motors with voltage control.
- Several fans can be controlled from the same unit in case the total consumption current does not exceed the permissible controller current value.

### Design and control

- The controller casing is made of plastic and on/off button with light indicator.
- The controller is featured with high efficiency and control accuracy.
- Regulation starts from the minimum to the maximum voltage value. The maximum speed produces the smoothest rotation.

- The minimum speed value is set by a variable resistor located at the controller circuit board.

### Protection

- The input circuit of the speed controller is equipped with a melting fuse for overload protection.
- The controller is equipped with a transient filter.

### Mounting

- The regulator is designed for indoor installation.
- The casing design allows mounting the controller on the wall (N modification) or inside the wall (V modification).

### Technical data

	RS-1 N (V)	RS-1,5N (V)	RS-2 N (V)	RS-2,5 N (V)
Voltage [V] at 50 Hz	1- 230	1- 230	1- 230	1- 230
Rated current [A]	1,0	1,5	2,0	2,5
Overall dimensions LxBxH [mm]	162x80x70	162x80x70	162x80x70	162x80x70
Maximum ambient temperature [°C]	40	40	40	40
Protection	IP 30	IP 30	IP 30	IP 30
Weight [kg]	0,3	0,3	0,3	0,3

## Speed controller RS...PS

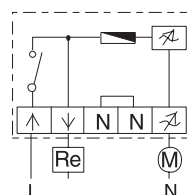
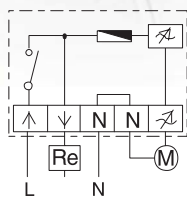

Controller wiring diagram

### Application

- Used in ventilation systems for switching on/off and speed control of single-phase fan motors with voltage control.
- Several fans can be controlled from the same unit in case the total consumption current does not exceed the permissible controller current value.

### Design and control

- The casing is made of plastic.
- The control knob is equipped with a light indicator that displays a current operation mode.
- The controller is featured with high efficiency and control accuracy.
- Start the controller by pressing the button.
- Regulation starts from the minimum to the maximum voltage value. The maximum speed produces the smoothest rotation.

- The minimum speed value is set by a variable resistor located at the controller circuit board.

- Controller is equipped with an extra terminal (230 V) for connection and control of the external equipment.

### Protection

- The input circuit of the speed controller has overload protection.
- Controller is equipped with a transient filter.

### Mounting

- The controller is suitable for indoor installation on the wall.
- The versatile casing design allows fan mounting on the wall or inside the wall.
- Suitable for installation inside the round junction boxes.

### Technical data

	RS-0,5-PS	RS-1,5-PS	RS-2,5-PS	RS-4,0-PS
Voltage [V] at 50 Hz	1- 230	1- 230	1- 230	1- 230
Minimum current [A]	0,1	0,15	0,25	0,4
Maximum current [A]	0,5	1,5	2,5	4,0
Overall dimensions LxBxH [mm]	82x82x65	82x82x65	82x82x65	82x82x65
Maximum ambient temperature [°C]	35	35	35	35
Protection	IP 44	IP 44	IP 44	IP 44
Weight [kg]	0,23	0,24	0,29	0,36

**Speed controller  
RSA-0,3**



**Application**

• RSA speed controller is used for air capacity control of single-speed fans with low power consumption by step speed control of electric motors. Several fans can be controlled from the same unit in case the total consumption current does not exceed the permissible controller current value.

**Design**

• The controller casing is made of high-quality plastic.  
• Speed controller has four speeds with output frequency 160 V - 180 V - 200 V - 230 V. Speed controller is equipped with on/off light indicator and control knob for speed switch.

**Protection**

• For overload protection the controller is equipped with a replaceable melting fuse.

**Mounting**

• Transformer speed controller is designed for indoor installation. Provide sufficient air circulation for cooling of the internal circuits and do not install the speed controller above heating equipment.

**Technical data**

	RSA-0,3
Voltage [V] at 50 Hz	1- 230
Output power, no more [VA]	60
Maximum load current [A]	0,3
Overall dimensions LxBxH [mm]	162x80x70
Maximum ambient temperature [°C]	+40
Protection	IP 30
Weight [kg]	0,65

Speed control provides not only the best ventilation mode for periodically visited premises but considerable reduction of energy consumption.

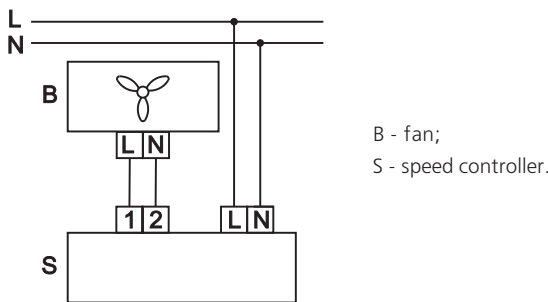



## Speed switch P2-1-300 P3-1-300



### Application

- Used for switching the fan on/off and speed selection for the fans with multiple-stage fans.

### Design and control

- The switch casing is made of plastic.
- Both direct speed switching (wiring diagram 1 and 3) and fan switching and speed control in parallel with light in the room (wiring diagrams 2 and 4).

### Mounting

- The speed switch is designed for indoor installation on the wall inside a flush junction mounting box.
- Suitable for installation inside the round junction boxes.

### Technical data

	P2-1-300	P3-1-300
Voltage [V] at 50 Hz	1- 230	1- 230
Rated current [A]	5,0	5,0
Number of speeds	2	3
Overall dimensions LxBxH [mm]	88x88x51	88x88x51
Maximum ambient temperature [°C]	40	40
Protection	IP 40	IP 40
Weight [kg]	0,13	0,13

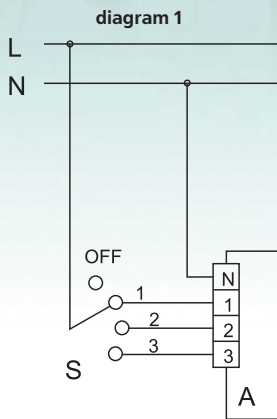

Fan is manually switched to one of three speeds by speed switch S (f.e. P3-1-300) or switched off.

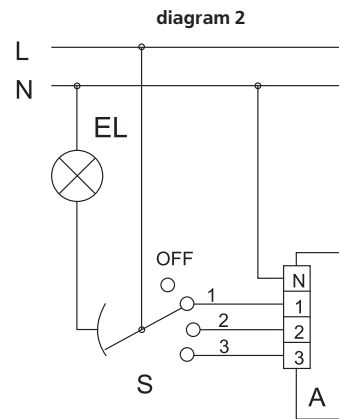

Fan is manually switched to one of three speeds by speed switch S (f.e. P3-1-300) with parallel switching of the light in the room or is switched off with parallel switching off the light in the room. The fan cannot operate without light and vice versa.

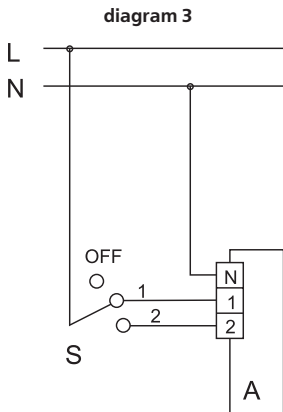

Fan is manually switched to one of two speeds by speed switch S (f.e. P2-1-300) or switched off.

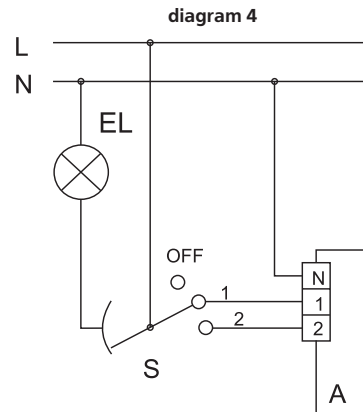

Fan is manually switched to one of two speeds by speed switch S (f.e. P2-1-300) with parallel switching off the light in the room. The fan cannot operate without light and vice versa.

### Speed switch connections

**Speed switch**  
**P2-5,0 N(V)**  
**P3-5,0 N(V)**  
**P5-5,0 N(V)**



**Application**

- Used for switching the fan on/off and speed selection for the fans with multiple-stage fans.

**Design and control**

- The switch casing is made of plastic and equipped with on/off button and operation light indicator.
- Speed switch is used either for local speed switch by rotating a control knob or can be

used as a remote wire control panel connected with multi-speed transformer speed controllers. P5-5,0 speed switch can be connected to transformer speed controller.

**Mounting**

- The speed switch is designed for indoor installation.
- The casing design allows mounting on the wall (N modification) or inside the wall (V modification).

**Technical data**

	P2-5,0	P3-5,0	P5-5,0
Voltage [V] at 50 Hz	1- 230	1- 230	1- 230
Rated current [A]	5,0	5,0	5,0
Number of speeds	2	3	5
Overall dimensions LxBxH [mm]	162x80x70	162x80x70	162x80x70
Maximum ambient temperature [°C]	40	40	40
Protection	IP 30	IP 30	IP 30
Weight [kg]	0,25	0,25	0,25

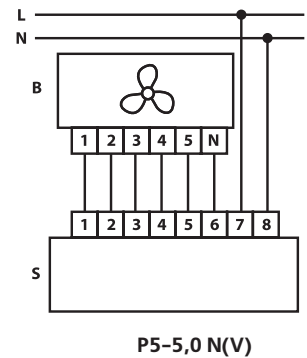
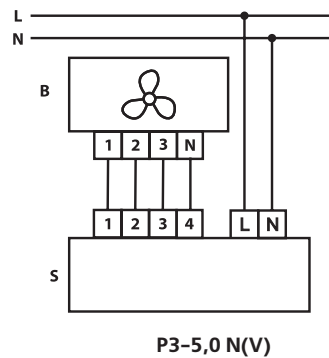
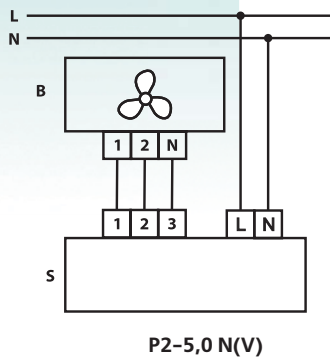

B - fan;  
S - switch.

Speed switch connections

## Temperature regulator RTS-1-400 RTSD-1-400



### Regulator connections

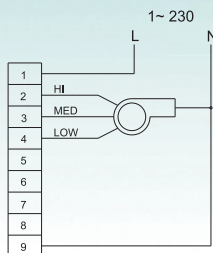

Ventilation with heating and cooling

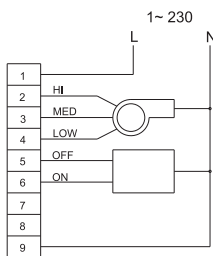

Fans with heating and cooling three-way SPDT valve system

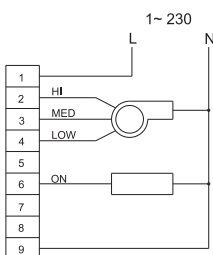

Ventilation with heating and cooling two-way SPST valve system

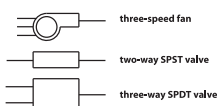

### Application

- Temperature regulation of the ventilation, heating and air conditioning systems.
- Used for control of fans and fancoil valves, air heating units equipped with three-speed fans 230 V.
- Automatic control of the heating/cooling rate.

### Design and control

- Temperature sensor is incorporated into the remote Controller.
- The front of the remote controller includes a digital LCD display and control buttons.
- Display shows both current and set air temperature and the selected mode - cooling, heating, automatic mode as well as the fan set speed.
- Fan speed is manually adjustable with control buttons.

- Automatic regulation of the heating/cooling rate (high/medium/low) depending on the air temperature in the room.

- Display light allows to use the remote controller in bad light conditions.
- Temperature maintaining accurate to 1°C.
- Setting saving at power cutoff.
- RTS-1-400 model is equipped with a remote control panel.
- «Night» operation mode (refer operating schedule during night time).

### Mounting

- Remote controller is designed for indoor wall mounting.
- The recommended installation height is 1.5 m from the floor.
- Do not install the remote controller close to windows, doors and heating equipment.

### Technical data

	RTS-1-400	RTSD-1-400
Voltage [V] at 50 Hz	1- 230	1- 230
Rated current [A]	2,0	2,0
Number of speeds	3	3
Temperature range °C	+10...+30	+10...+30
Overall dimensions LxBxH [mm]	88x88x51	88x88x51
Maximum ambient temperature [°C]	40	40
Protection	IP 40	IP 40
Remote control	no	yes

### Night duty operation peculiarities

- **Operation algorithm of the thermal regulator in heating mode:** in 30 min after night duty is activated the temperature in the room drops by 1 °C. Within next two consecutive hours the temperature drops by 2 °C and remains on this level within 8 hours. After timer is off the temperature rises to the default level automatically.

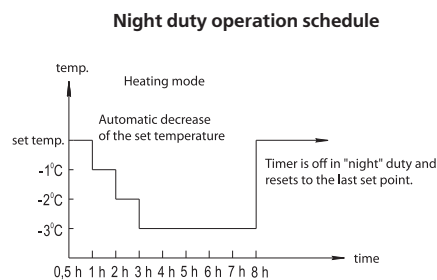

- **Operation algorithm of the thermal regulator in cooling mode:** in 30 min after night duty is activated the temperature in the room rises by 1 °C, in 1 hour it rises by 1 °C more and remains on this level within 8 hours. After timer is off the temperature drops to the default level automatically.

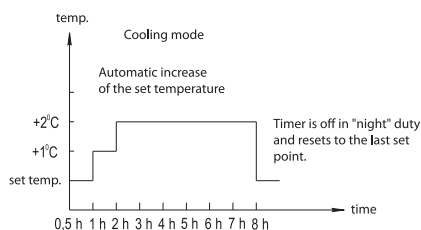

## Temperature regulator RT - 10



### Application

• Used for temperature control in the room and control of ventilation, heating and conditioning systems.

### Design and control

- The casing is made of durable casing.
- As the temperature decreases or increases the thermostat can break or close the contacts. The operation mode is selected while connection.
- Temperature range from +10 °C to +30 °C.

### Mounting

- Thermostat is designed for indoor wall mounting.
- The recommended installation height is 1.5 m from the floor.
- Do not install the thermostat close to windows, doors and heating equipment.

### Technical data

	RT-10
Voltage 50/60 Hz [V]	1- 220-240
Overall dimensions LxBxH [mm]	84x84x35
Maximum ambient temperature [°C]	40
Protection	IP 40

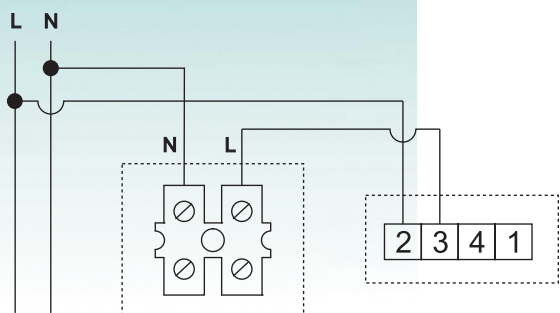

Fan operates until it reaches the pre-set temperature threshold

fig. 1

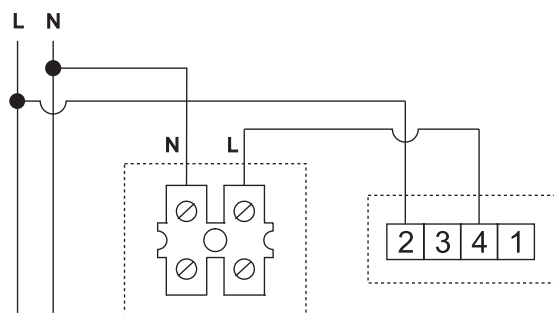

Fan starts operation as the temperature reaches the threshold value set by the thermostat.

fig. 2

### Regulator connections

#### For wiring diagram fig. 1

- maximum active load current no more 10A;
- maximum inductive load current no more 3A.

#### For wiring diagram fig. 2

- maximum active load current no more 6A;
- maximum inductive load current no more 2A.

## Insulating transformer TRF-220/12-25



### Application

- Low-voltage step-down transformers are used in humid premises as bathroom and kitchen with low-voltage (12 V) safety requirements. TRF transformers are used to provide safe power voltage 12 V/ 50 Hz for the domestic fans not more than 16 W (25VA) with current load up to 2 A.

### Design

- Transformer for flush mounting. The transformer casing is made of plastic and supplied with a protective terminal box. Electrical connection of the fan with the safe voltage 12 V is done through the output terminal block.
- For overload protection the transformer is equipped with a replaceable melting fuse built in the input terminal board.
- Protection rating (except terminal blocks) IP 40.

### Mounting

- Transformer is designed for indoor installation in areas not subjected to high humidity and temperature influence.
- Transformer is designed for ceiling flush mounting or recess wall mounting. In case of installation into a junction box provide sufficient air ventilation to prevent the device overheating.
- Observe the applicable fire safety requirements while installation and operation. Do not install transformers above heating equipment.

### Technical data

TRF-220/12-25	
Voltage [V] at 50 Hz	1- 230
Output voltage [V] / 50 Hz	12
Max. load power, no more	16 (25 VA)
Maximum load current [A]	2,0
Overall dimensions LxBxH [mm]	Transformer 91x58x62 Terminal box 110x40x40
Maximum ambient temperature [°C]	+40
Protection	IP 40
Weight [kg]	0,8

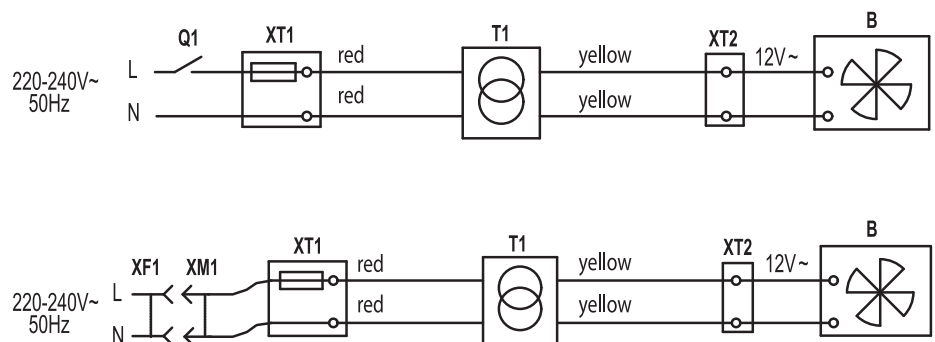

Transformer wiring diagrams

- Q1 - external switch integrated into fixed wiring system;
- XT1 - input terminal block with built-in fuse in the protecting terminal box;
- XF1 - socket integrated into fixed wiring system;
- XM1 - standard wall plug;
- T1 - transformer;
- XT2 - output terminal block for connection of 12 V fan.
- B - low voltage fan, 12 V.

## Insulating transformer TRF-220/12-25 K TRF-220/12-25 KV



### Application

• Low-voltage step-down transformers are used in humid premises as bathroom and kitchen with low-voltage (12 V) safety requirements. TRF transformers are used to provide safe power voltage 12 V / 50 Hz for the domestic fans not more than 16 W (25VA) with current load up to 2 A.

### Design

- TRF-220/12-25 K transformer in plastic casing for wall mounting.
- TRF-220/12-25 KV transformer in plastic casing for wall mounting with a built-in switch. The casing is equipped with a light indicator.
- For overload protection the transformer is equipped with a replaceable melting fuse.

### Modifications and options



**KV** – equipped with a pull cord switch.



**KT** – equipped with a regulated timer with the operating time from 2 to 30 minutes.

### Technical data

	TRF-220/12-25 K
Voltage [V] at 50 Hz	1~ 230
Output voltage [V] / 50 Hz	12
Max. load power, no more	16 (25VA)
Maximum load current [A]	2,0
Overall dimensions LxBxH [mm]	80x162x63
Maximum ambient temperature [°C]	+40
Protection	IP 30
Weight [kg]	0,85



**KTH** – equipped with a timer with the operating time from 2 to 30 minutes and a humidity sensor with the threshold value from 60 to 90%.



**KTP** – equipped with a regulated timer and a motion sensor with the sensitivity area from 1 to 4 m and the detection angle up to 100°.

### Mounting

- Transformer is designed for indoor installation in areas not subjected to high humidity and temperature influence.
- Transformer is designed for wall mounting. Provide sufficient air circulation for cooling of the internal circuits.
- Observe the applicable fire safety requirements while installation and operation. Do not install transformers above heating equipment.

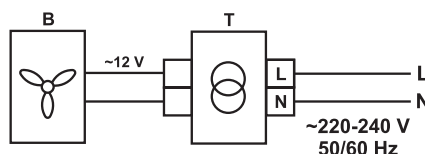

TRF-220/12-25 K

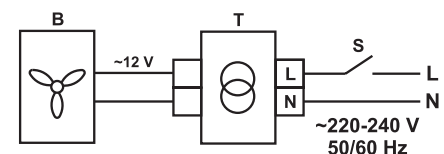

TRF-220/12-25 KV

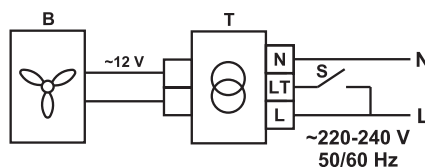

TRF-220/12-25 KT / KTH

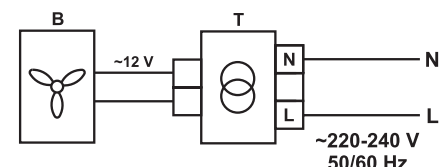

TRF-220/12-25 KTP

### Transformer wiring diagrams

B - low voltage fan, 12 V;  
T - protective transformer;  
S - external switch.

## Back valve KO series



### Application

- To prevent air back drafting.
- Does not disturb passive indoor ventilation.
- For domestic fan series VENTS M, M1, D, S, M3, X, X1, LD, LD Fresh time, Silenta-M, Silenta-S, Modern, Vitro star, Z star, X star.
- Designed for connection to  $\varnothing$  100, 125 and 150 mm air ducts.

### Design

- Casing made of ABS plastic and the membrane is made of special light polymer.

### Mounting

- Back valve is mounted on a fan with special fasteners provided on the fan spigot.



### Overall dimensions

Model	Dimensions [mm]	
	$\varnothing$ D	a
KO 100	100	14
KO 125	125	14
KO 150	150	14

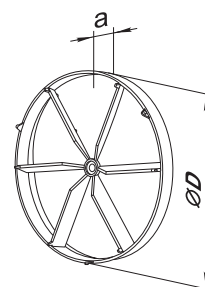

## Alphabetic index

<b>B</b>			
BU-1-60.....	116	P3-5,0 N(V).....	121
<b>C</b>		P5-5,0 N(V).....	121
CF.....	106	PF.....	58
CF3.....	108	PF 1.....	60
<b>D</b>		<b>Q</b>	
D.....	64	Quiet.....	24
Domino.....	80	<b>R</b>	
<b>F</b>		RS-1-300.....	117
F.....	50	RS-1-400.....	117
F1.....	52	RSA-0,3.....	119
<b>I</b>		RS...N (V).....	118
iFan.....	20	RS...PS.....	118
iFan Move.....	20	RT -10.....	123
<b>K</b>		RTS-1-400.....	122
K.....	54	RTSD-1-400.....	122
KO.....	126	<b>S</b>	
K1.....	56	S.....	62
<b>L</b>		Silenta-M.....	26
LD.....	68	Silenta-S.....	28
LD Auto.....	70	<b>T</b>	
LD Fresh time.....	74	TRF-220/12-25.....	124
LD light.....	72	TRF-220/12-25 K.....	125
<b>M</b>		TRF-220/12-25 KV.....	125
M.....	38	<b>V</b>	
M1.....	42	VV.....	102
M1OK2.....	100	VVR.....	102
M3.....	40	Vitro.....	86
MA.....	44	Vitro star.....	88
MAO1.....	96	VKO.....	32
MAO1 Reverse.....	98	VKOk.....	32
MAO2.....	96	VKO1.....	34
MA Reverse.....	46	VKO1K.....	34
Modern.....	76	<b>X</b>	
Modern Auto.....	78	X.....	90
<b>P</b>		X1.....	48
P2-1-300.....	120	X star.....	92
P2-5,0 N(V).....	121	<b>Z</b>	
P3-1-300.....	120	Z.....	82
		Z star.....	84



**VENTILATION SYSTEM**  
[www.ventilation-system.com](http://www.ventilation-system.com)

domestic fans



VENTS reserves the rights to modify any of its products' features, designs, components and specifications at any time and without notice to maintain the development and quality of manufactured goods.

06/2013

