

# A PRACTICAL GUIDE TO THE MEASUREMENTS ON ELECTRICAL INSTALLATIONS

*In accordance with IEC 60364-6 standard.*

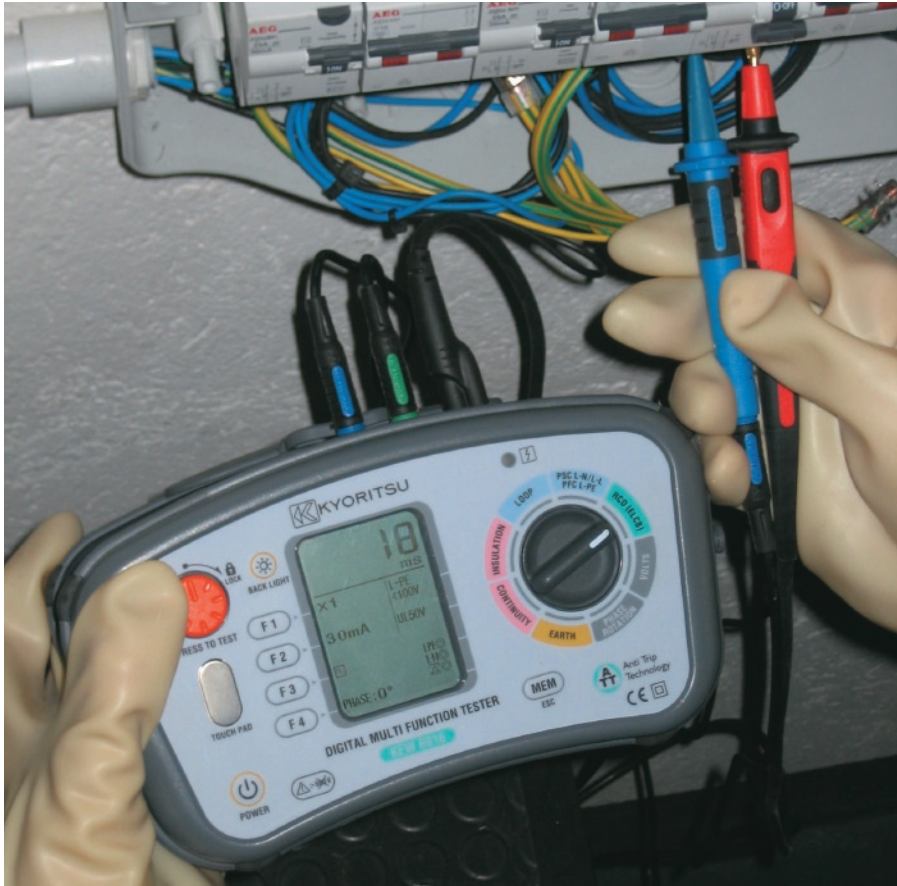

**Kyoritsu Electrical  
Instruments Works, LTD**

**ISO 9001  
BUREAU VERITAS  
Certification**



008

# CONTENTS.

	Page
1. Preface.....	1
2. Standards .....	2
3. Electrical Systems .....	3
4. When must the tests be carried out? .....	4
5. Requirements for Testing an Electrical Installations .....	4
6. Electrical Testing for Initial verification.....	5
6.1 Continuity of protective conductors including the main and supplementary equipotential bonding conductors.....	5
6.2 Insulation resistance .....	6
6.3 Protection by SELV, PELV or by Electrical Separation .....	7
6.4 Insulation resistance of Non Conducting Floors and Walls .....	7
6.5 Verification of conditions for protection by automatic disconnection of the supply.....	9
6.6 Polarity and Phase sequence test .....	16
6.7 Functional tests .....	17
6.8 Verification of voltage drop.....	17
7. Electrical testing for Periodic Verification .....	18
7.1 Frequency of Electrical testing for Periodic Verification .....	18
8. Reporting for Verification .....	19
9. Cross-Table Tests / Instruments .....	21

## 1. PREFACE.

### *AIM OF THE MANUAL "PRACTICAL GUIDE TO THE MEASUREMENTS ON ELECTRICAL INSTALLATIONS.*

This guide offers the reader practical information and examples on carrying out the test measurements required by the International Standard IEC 60364 "Electrical Installation of Buildings – Part 6: Verification". In particular, with the help of illustrated examples, it describes the execution of tests giving the limit values as stipulated in the Standard.

This guide is intended for persons carrying out the testing of low-voltage electric installations in buildings or responsible for the maintenance of these installations. All the information, considerations and tables shown in this pamphlet were obtained following the Standards in force during the preparation of this pamphlet. Kyoritsu Electrical Instruments Works, LTD informs that this guide is not a substitute for the International Standard IEC 60364, which should always be consulted in case of doubt.

## 2. STANDARDS.

To ensure the safety of the electrical installations and their safety during testing, the International Electrotechnical Commission (IEC) and the CENELEC (European Committee for Electrotechnical Standardisation) have prepared the appropriate Standards listed below:

- **IEC 60364 series** “Electrical Installation of Buildings” In particular the Part 6 is dedicated to the Verification.  
Several countries have adopted, in part or completely, IEC 60364 series within their own national regulations, most of which are listed below:
  - Austria ÖVE / ÖNORM E8001
  - Australia AS 3000: 2000
  - Czech Republic ÖSN 332000-4-41, ÖSN 332000-6-61
  - Denmark Stærkstrømsbekendtgørelsen 6
  - Finland SFS 6000 series 1-7, SFS 6000-8
  - France NF C 15 – 100
  - Greece IEC 60364-6, ELOT-HD 384.
  - Hungary MSZ 172, MSZ 4851
  - Germany VDE 0100 series
  - Italy CEI 64 - 8
  - New Zealand NZS 3000: 2000
  - Norway NEK 400
  - Poland PN - IEC 60364 series
  - Spain UNE 20 - 460 series
  - Sweden SS436 46 61, SS-EN 60364 series
  - Switzerland NIV / SN SEV 1000
  - U.K. ,Malta and Cyprus BS 7671, IEE Wiring Regulations 17th edition
- **IEC 61557, EN 61557 series** “Electrical Safety in Low Voltage Distribution Systems up to 1000V a.c. and 1500V d.c. – Equipment for testing, measuring or monitoring of protective measures”.  
This series of standards has been established with the aim of stipulating common principles (of features and safety) for testing instruments used for electrical installations up to 1000 V a.c. and 1500 V d.c.  
The EN 61557 standard is divided into several parts, each of them dedicated to one measurement or topic as follows:
  - EN 61557 Part 1 General Requirements
  - EN 61557 Part 2 Insulation Resistance
  - EN 61557 Part 3 Loop Impedance
  - EN 61557 Part 4 Continuity of PE and Equipotential Bonding
  - EN 61557 Part 5 Resistance of Earth
  - EN 61557 Part 6 Residual Current Devices (RCDs) in TT, TN, IT.
  - EN 61557 Part 7 Phase sequence
  - EN 61557 Part 10 Combined measuring equipment (Multifunction)
- **IEC 61010-1, EN 61010-1** “Safety requirements for electrical Equipment for measurement, control and laboratory use”.  
This standard has been established with the aim of defining the general safety requirements for measurement instruments.

### 3. ELECTRICAL SYSTEMS.

An electrical system consists of a single source of electrical energy and an installation. Depending on the relationship between the source and the exposed (conductive) part of the installation to Earthing, the standards define the type of system as follows:

- **TT System:** the accessible conductive parts are earthed independently of the source earth (Fig 1).

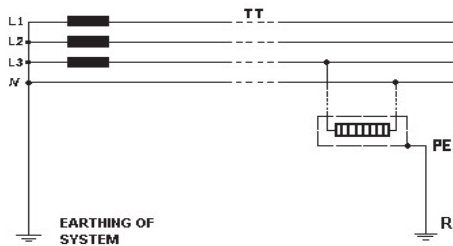

Fig 1

- **TN System:** the accessible conductive parts are connected to the source earth (Fig 2).

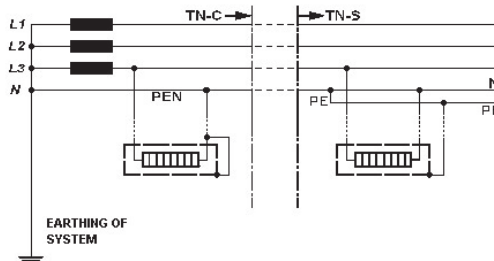

Fig 2

- **IT System:** the live parts are insulated from the earth (or connected to earth through an impedance  $Z$ ), the accessible conductive parts are earthed independently (Fig 3).

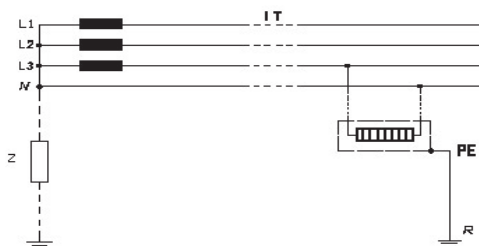

Fig 3

## 4. WHEN MUST THE TESTS BE CARRIED OUT?

The international standard IEC 60364-6 provides requirements for **Initial Verification** and **Periodic Verification** of an electrical installation:

**Initial Verification** consists of visual inspection and testing, of an electrical installation to determine, as far as reasonably practicable, whether the requirements of the other parts of IEC 60364 have been met, including requirements for the reporting of the testing results.

The Initial Verification takes place upon completion of a new installation or completion of additions or of alterations to existing installations.

**Periodic Verification** provides the frequency and the requirements for periodic verification of an electrical installation to determine, as far as reasonably practicable, whether the installation and all its constituent equipments are in a satisfactory condition for use, including requirements for the reporting of the testing results. Chapter 7 of this guide reports some consideration of periodic inspection.

This guide will not consider visual inspections (for example the checking of the method of protection against the electric shock like barriers and distances, colour and size of the conductors, presence of the diagrams, appropriate selection of materials, etc.) but will focus on the various testing regimes and the stipulated values which these tests should deliver.

## 5. REQUIREMENTS FOR TESTING AN ELECTRICAL INSTALLATION.

The following tests shall be carried out where relevant and should preferably be made in the following sequence:

- Continuity of the protective conductors and of the main and supplementary equipotential bonding conductors.
- Insulation resistance of the electrical installation.
- Protection by SELV and PELV or by electrical separation.
- Insulation Resistance of non-conducting floors and walls.
- Verification of conditions for protection by automatic disconnection of the supply (Fault Loop impedance, Earth resistance, RCD test).
- Polarity and phase sequence tests.
- Functional and operational tests.
- Voltage drop.

The international standard IEC 60364-6 requires that all measuring instruments and monitoring equipment used for above tests comply with the series IEC / EN 61557. If other testing equipment is used, it shall provide the same degree of performance and safety as a minimum.

## 6. ELECTRICAL TESTING FOR INITIAL VERIFICATION.

### 6.1 Continuity of protective conductors including the main and supplementary equipotential bonding conductors.

The IEC 60364-6 requires that continuity protective conductors, main and supplementary equipotential bonding shall be tested to determine their suitability to carry fault current and system load current. In case of ring final circuits connected to a single point of supply shall be tested also the live conductors.

The IEC 61557 requires that the appropriate instruments shall be able to supply a minimum current of 200 mA with a no-load voltage between 4 to 24 V d.c. or a.c.

The instrument used for the examples below, can perform the continuity test with the current and voltage specified, measuring the resistance of the conductor under test.

Figures 4 and 5 show the continuity test for PE and main equipotential bonding conductors respectively.

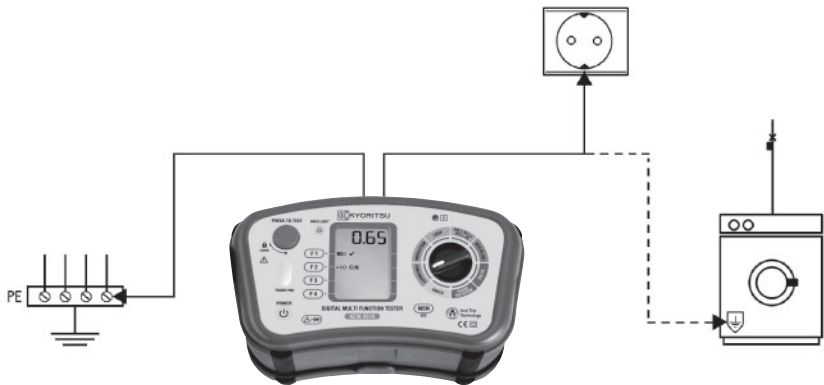

Fig 4

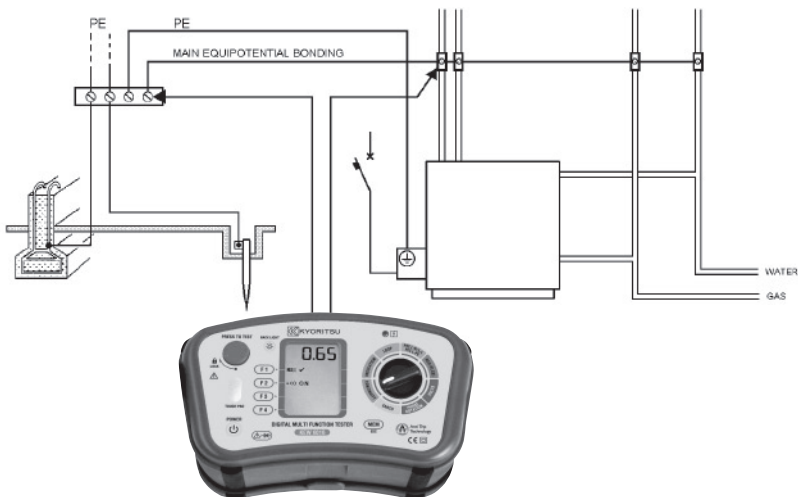

Fig 5

## 6.2 Insulation resistance of the electrical installation.

The insulation resistance shall be measured between each live conductor and the protective conductor or earth. In locations exposed to fire hazards, a measurement of the insulation resistance between the live conductors shall be taken.

The insulation resistance, measured with the test voltage values indicated in the table below are satisfactory if each circuit, with the appliances disconnected, has an insulation resistance not less than the appropriate value given in the same table.

Nominal circuit Voltage	Test voltage d.c.	Insulation resistance
SELV, PELV ( $\leq 50$ V a.c. $\leq 120$ V d.c.)	250 V	$\geq 0.5$ M $\Omega$
Up to and including 500 V (including FELV)	500 V	$\geq 1$ M $\Omega$
Above 500 V	1000 V	$\geq 1$ M $\Omega$

Typically for 230/400 V circuits (excluding SELV and PELV), IEC 60364-6 requires that the insulation resistance at a test voltage of 500 V d.c. shall be 1 M $\Omega$  as a minimum.

The example below (Fig 6) shows the insulation resistance test on a 4 wire -3 phase system.

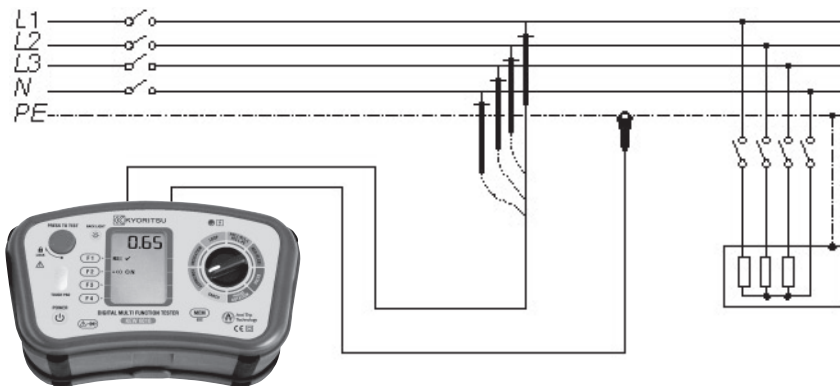

Fig 6

Note: Where surge protective devices (SPDs) are likely to influence the test or be damaged, such equipment shall be disconnected before carrying out the insulation resistance test. Where it is not reasonably practicable to disconnect such equipment (e.g. in case of fixed socket-outlets incorporating an SPD), the test voltage for the particular circuit may be reduced to 250 V d.c., but the insulation resistance must have a value of at least 1 M $\Omega$ .

### 6.3 Protection by SELV, PELV or by Electrical Separation.

Even if the automatic disconnection of supply by circuits-breakers, fuses and RCDs, is normally the most common protection method, there are other protection methods like protection by SELV, PELV or by Electrical Separation or by Non conducting Floors and Walls.

Only for these cases shall the separation of live parts from those of other circuits, be confirmed by a measurement of the insulation resistance.

The resistance values obtained must be in accordance with Table on page 6.

Below there is an example of the measurement of insulation resistance to confirm the separation of live parts from those of other circuits (Fig 7).

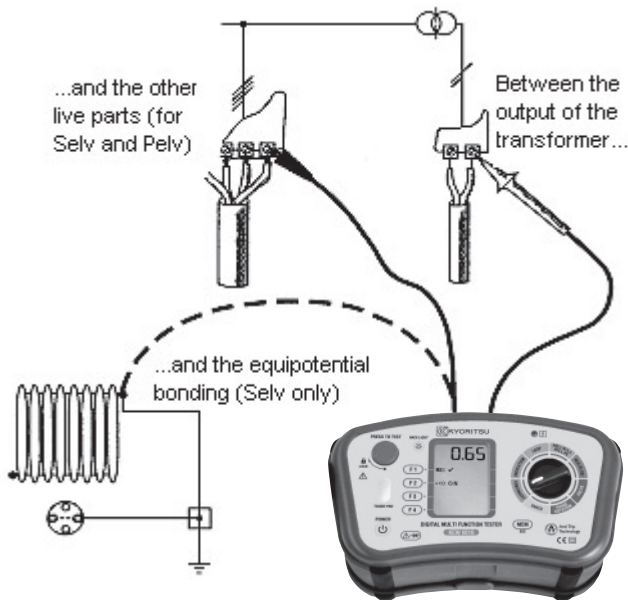

Fig 7

### 6.4 Insulation Resistance of Non Conducting Floors and Walls.

When it is necessary to comply with the requirements of the protection by non-conducting locations, the floor and wall insulation resistance/impedance shall be tested.

In Part 6 of IEC 60364 methods for measuring the insulating resistance / impedance of floors and walls are given as examples.



## 6.5 Verification of conditions for protection by automatic disconnection of the supply.

Automatic disconnection of supply is required where a risk of harmful pathophysiological effects to a person may arise due to a fault as a result of the value and duration of the touch voltage.

The verification of the efficacy of the measures for protection against indirect contact by automatic disconnection of supply is treated below.

### a) In case of TN systems

According to the International Standard IEC 60364, for TN system the characteristics of the protective device and the circuit impedance shall fulfil the following requirement:

$$Z_s \times I_a \leq U_o$$

Where:

**Z<sub>s</sub>** is the Fault loop impedance in ohm.

**U<sub>o</sub>** is the nominal voltage between phase to earth (typically 230V AC for both single phase and three phase circuits).

**I<sub>a</sub>** is the current causing the automatic disconnection of the protective device within the maximum disconnecting times required by IEC 60364-41 that are:

- 400 ms for final circuits not exceeding 32A (at 230 / 400V AC)
- 5 s for distribution circuits and circuits over 32A (at 230 / 400V AC)

The compliance with the above rules shall be verified by:

**1)** Measurement of the fault loop impedance **Z<sub>s</sub>** by Loop tester.

**2)** Verification of the characteristics and/or the effectiveness of the associated protective device. This verification shall be made:

- for circuit-breakers and fuses, by visual inspection (i.e. short time or instantaneous tripping setting for circuit-breakers, current rating and type for fuses);
- for RCDs, by visual inspection and test using RCD testers recommending that the disconnecting times mentioned above are met.

For instance in a TN system with nominal mains voltage  $U_o = 230\text{ V}$  protected by General purpose **gG fuses** or **MCBs** (Miniature Current Breakers) required by IEC 898 / EN 60898, the **I<sub>a</sub>** and max **Z<sub>s</sub>** values could be:

Rating (A)	Protection by gG fuses with $U_0$ of 230V				Protection by MCBs with $U_0$ of 230V (Disconnection time 0.4 and 5s)					
	Disconnection time 5s		Disconnection time 0.4s		Characteristic B		Characteristic C		Characteristic D	
	$I_a$ (A)	$Z_s$ ( $\Omega$ )	$I_a$ (A)	$Z_s$ ( $\Omega$ )	$I_a$ (A)	$Z_s$ ( $\Omega$ )	$I_a$ (A)	$Z_s$ ( $\Omega$ )	$I_a$ (A)	$Z_s$ ( $\Omega$ )
6	17	13.5	38	8.52	30	7.67	60	3.83	120	1.92
10	31	7.42	45	5.11	50	4.6	100	2.3	200	1.15
16	55	4.18	85	2.7	80	2.87	160	1.44	320	0.72
20	79	2.91	130	1.77	100	2.3	200	1.15	400	0.57
25	100	2.3	160	1.44	125	1.84	250	0.92	500	0.46
32	125	1.84	221	1.04	160	1.44	320	0.72	640	0.36
40	170	1.35	--	--	200	1.15	400	0.57	800	0.29
50	221	1.04	--	--	250	0.92	500	0.46	1000	0.23
63	280	0.82	--	--	315	0.73	630	0.36	1260	0.18
80	403	0.57	--	--						
100	548	0.42	--	--						

The most complete loop testers or Multifunction testers also have the Prospective Fault current measurement. In this case, Prospective Fault current measured with instruments must be higher than the tabulated  $I_a$  of the protective device concerned.

Below is a practical example of verification of the protection by MCB in a TN system according to the international Standard IEC 60364 (Fig 8).

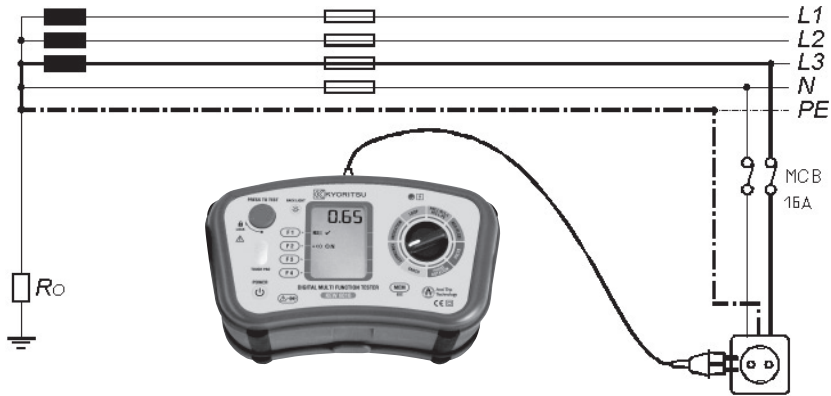

Fig 8

Max value of  $Z_s$  for this example is 1.44 $\Omega$  (MCB 16A, characteristic C), the instrument reads 1.14 $\Omega$  (or 202 A on Fault current range) it means that the condition  $Z_s \times I_a \leq U_0$  is respected.

In fact the  $Z_s$  of 1.14 $\Omega$  is less than 1.44 $\Omega$  (or the Fault current of 202 A is more than  $I_a$  of 160A).

In other words, in case of fault between phase and earth, the wall socket tested in this example is protected because the MCB will trip within the disconnection time required.

## Operation of Residual Current Devices (RCDs) in TN system.

Given that when the protective device is an RCD,  $I_a$  is typically 5 times the rated residual operating current  $I_{\Delta n}$ , then the RCD must be tested using RCD testers or Multifunction testers recommending that the disconnecting times required in IEC 60364-41 are confirmed.

An RCD tester or a Multifunction tester can perform the tests for single phase and three phase RCDs by measuring the tripping time.

Below is an example of an RCD test on a TN system (Fig 9),

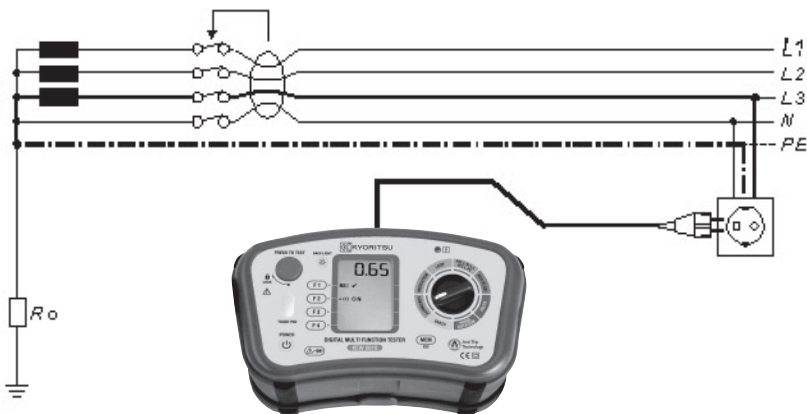

Fig 9

In a TN system at 230V / 400V, the tripping time measured by RCD tester or a Multifunction tester shall be lower than the maximum disconnecting times as defined by IEC 60364-41 that are:

- 400 ms for final circuits not exceeding 32A (at 230 / 400V AC)
- 5 s for distribution circuits and circuits over 32A (at 230 / 400V AC)

It is also good practice to consider even more stringent trip time limits, by following the standard values of trip times at  $I_{\Delta n}$  defined by IEC 1009 (EN 61009) and IEC 1008 (EN 61008). These trip time limits are listed in the table below:

Type of RCD	Test at $I_{\Delta n}$
General (G)	300 ms max. allowed value
Selective (S)	500 ms max. allowed value
	130 ms max. allowed value

*Note: These tripping time values are applicable to RCD's correctly installed according to the manufacturer specifications.*

## **b) In case of TT systems**

According to the International Standard IEC 60364, for TT systems the characteristics of the protective device and the circuit resistance shall fulfil the following requirements:

$$R_a \times I_a \leq 50V$$

Where:

**R<sub>a</sub>** is the sum of the resistances in  $\Omega$  of the local earth system and the protective conductor for the exposed conductive parts.

**50** is the maximum safety touch voltage limit (it can be 25V in particular cases like construction sites, agricultural premises, etc.).

**I<sub>a</sub>** is the current causing the automatic disconnection of the protective device within the maximum disconnecting times required by IEC 60364-41:

- 200 ms for final circuits not exceeding 32A (at 230 / 400V AC)
- 1000 ms for distribution circuits and circuits over 32A (at 230 / 400V AC)

The compliance with the above rules shall be verified by:

**1)** Measurement of the resistance  $R_a$  of the local earth system by Loop tester or Earth tester.

**2)** Verification of the characteristics and/or the effectiveness of the RCD associated protective device.

Generally in TT systems, RCDs shall be used as protective device and in this case, **I<sub>a</sub>** is the rated residual operating current  $I_{\Delta n}$ . For instance in a TT system protected by a RCD the max  $R_a$  values are:

<b>Rated residual operating current <math>I_{\Delta n}</math></b>	30	100	300	500	1000	<b>mA</b>
<b>RA (with touch voltage of 50V)</b>	1667	500	167	100	50	$\Omega$
<b>RA (with touch voltage of 25V)</b>	833	250	83	50	25	$\Omega$

Shown below is a practical example of verification of the protection by RCD in a TT system according to the international Standard IEC 60364.

The standard describes two methods for testing the resistance  $R_a$ :

-**Volt-ampere method**, using classical earth resistance testers or the most complete Multifunction testers by sticking two auxiliary earth electrodes into the ground (Fig 10).

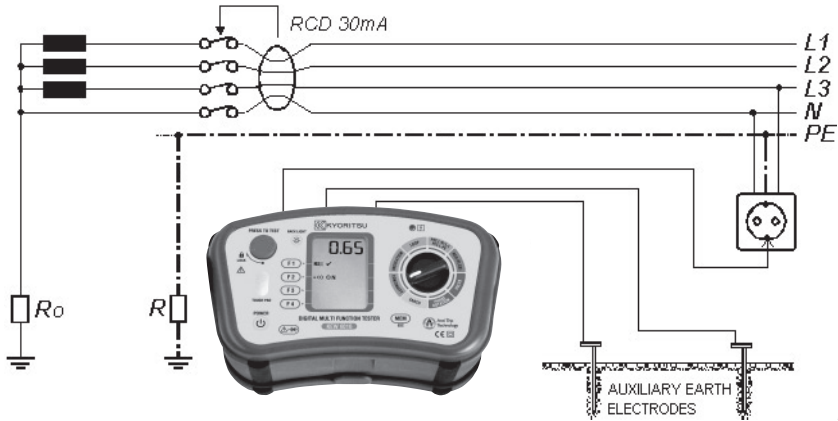

Fig 10

- **Fault loop impedance method (Loop tester)**. The IEC 60364-6 describes a safe and easy method to test earth resistance where, in a TT system, the location of the installation (e.g. in towns) does not in practice allow the two auxiliary earth spikes to be inserted into the ground.

This method consists of the measurement of the fault loop impedance with a Loop Tester or a Multifunction tester which, in a TT system, will in practice give the earth resistance (Fig11).

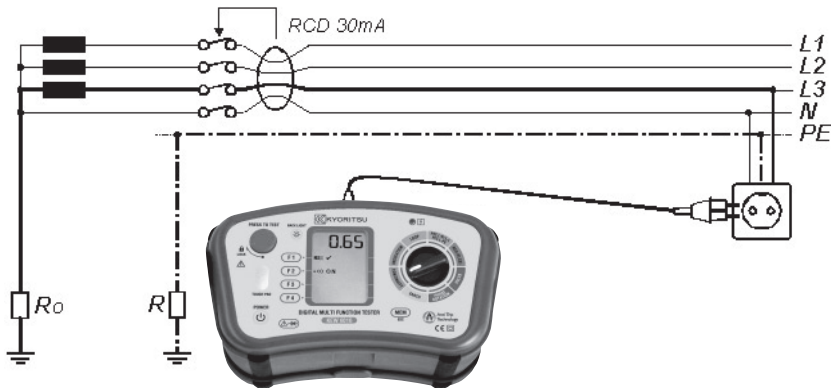

Fig 11

For these examples the max permissible value is  $1667\Omega$  ( $RCD = 30mA$  and contact voltage limit of 50 V). The instruments reads  $12.74\Omega$ , thus the condition  $RA \leq 50/Ia$  is respected. However, considering that the RCD is essential for protection, it must be tested as follows.

## Operation of Residual Current Devices (RCD's) in TT system.

Given that when the protective device is an RCD,  $I_a$  is typically 5 times the rated residual operating current  $I_{\Delta n}$ , then the RCD must be tested using RCD testers or Multifunction testers recommending that the disconnecting times required in IEC 60364-41 are confirmed.

The RCD testers or Multifunction testers can perform the tests for single phase and three phase RCDs by measuring the tripping time.

Below is an example of an RCD test on a TT system (Fig 12).

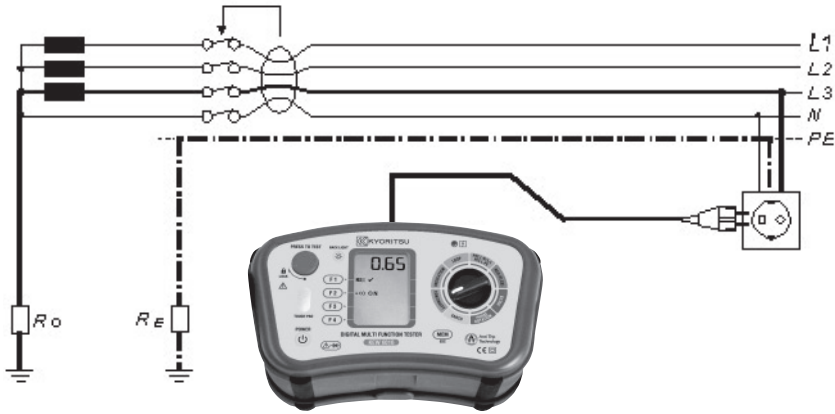

Fig 12

In TT system at 230V / 400V, the tripping time measured by an RCD tester or a Multifunction tester shall be lower than the maximum disconnecting times as defined by IEC 60364-41 that are:

- 200 ms for final circuits not exceeding 32A
- 1000 ms for distribution circuits and circuits over 32A.

It is also good practice to consider even more stringent trip time limits, by following the standard values of trip times at  $I_{\Delta n}$  defined by IEC 1009 (EN 61009) and IEC 1008 (EN 61008). These trip time limits are listed in the table below:

Type of RCD	Test at $I_{\Delta n}$
<b>General (G)</b>	300 ms max. allowed value
<b>Selective (S)</b>	500 ms max. allowed value
	130 ms max. allowed value

*Note: These tripping time values are applicable to RCD's correctly installed according to the manufacturer specifications.*

### **c) For IT systems**

Compliance with the rules of IEC 60364-4-41 shall be verified by calculation or measurement of the current in case of a first fault at the line conductor or at the neutral.

Where similar conditions to TT or TN systems occur, in the event of a second fault in another circuit, verification is made as for TT or TN systems as described above.

*Note: During the measurement of the fault loop impedance, it is necessary to establish a connection of negligible impedance between the neutral point of the system and the protective conductor preferably at the origin of the installation or, where this is not acceptable, at the point of measurement.*

-----

### **Measurement of the earth electrode resistance.**

The international standard IEC 60364-6 provides information regarding the measurement of the resistance of an earth electrode for TT, TN and IT systems. This measurement shall be made by the Volt-Amperometric method using two auxiliary earth electrodes.

The instrument that covers this requirement is the Earth Tester.

The drawing below shows a practical example of measurement of the earth electrode resistance (Fig 13).

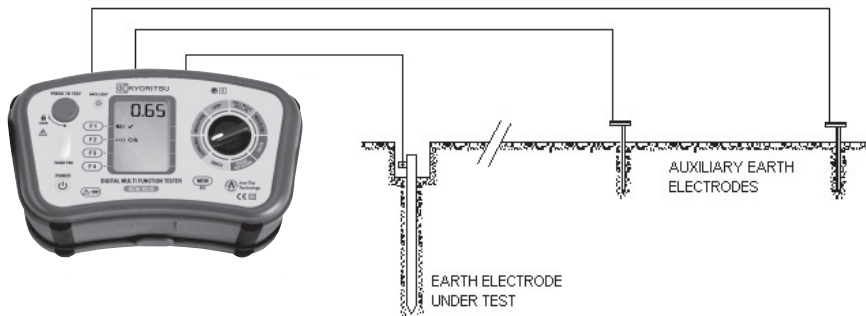

Fig 13

*Note:*

*The auxiliary earth electrodes must be placed at sufficient distance from the earth electrode under test in order to avoid overlapping of the resistance areas of the electrodes.*

## Measurement of the earth loop resistance with Earth Clamp.

The international standard IEC 60364-6 provides information regarding the measurement of the earth loop resistance with special clamp meters for Earth measurements.

This measuring method works with existing earth-loops within a meshed grounding system, as shown in Fig 14.

The Earth clamp induces a voltage  $U$  to the loop and it measures the current  $I$  within the loop.

The loop resistance can be calculated by dividing the voltage  $U$  by the current  $I$ . As the resulting value of parallel resistances  $R_1$  to  $R_n$  is normally negligible, the unknown resistance  $R_x$  measured by the earth clamp, is equal to the measured loop-resistance or a little lower.

This method is directly applicable to TN systems and within meshed earthing system of TT systems.

In TT systems, where only the unknown earth connection is available, the loop can be closed by a temporary link between earth electrode and neutral conductor (becomes equivalent to a TN system, quasi TN system) during measurement.

In this case, to avoid possible risks due to currents caused by potential differences between neutral and earth, the system should be switched off during connection and disconnection of this temporary link.

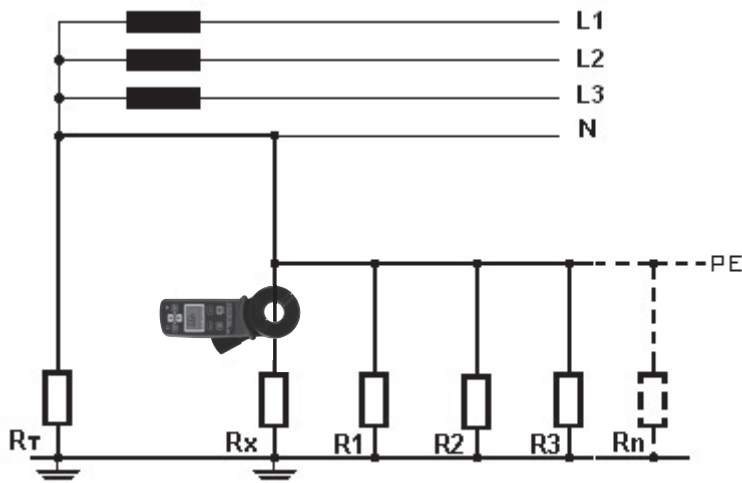

Fig 14

Where:

$R_T$  : Earth-connection of transformer.

$R_x$  : unknown earth-resistance to be measured.

$R_1 \dots R_n$  : parallel earth-connections connected by an equipotential bonding or a PEN conductor



## 6.6 POLARITY AND PHASE SEQUENCE TESTS.

Where the standard prohibits the use of single-pole switching devices for the neutral conductor, a test shall be made to verify that all such devices are used only for line conductor(s) .

Where the rules require double pole switches, a test shall be made to verify that the poles of such devices are connected correctly to the appropriate conductor.

In case of multiphase circuits it shall be verified that the phase sequence is maintained. In particular a test shall be made to verify that the devices (i.e. motors), are connected in the correct phase sequence by a Phase rotation tester.

Below are two examples: the Fig 15 shows a polarity test to determine the phase conductor using a Digital Multimeter as a voltmeter and the Fig 16 shows a phase sequence test to determinate the phase rotation.

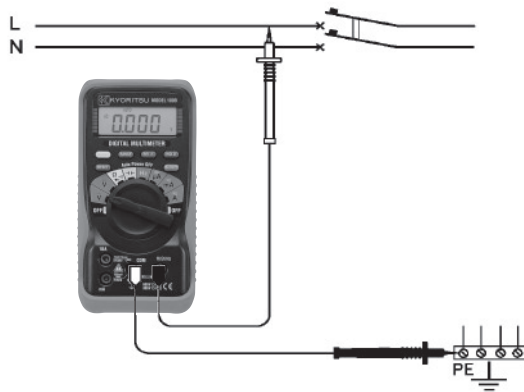

Fig 15

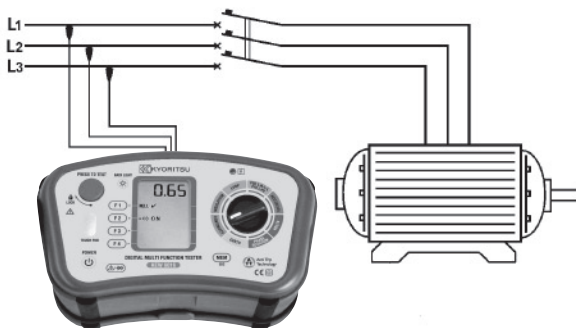

Fig 16

## 6.7 FUNCTIONAL TESTS.

Assemblies, such as switchgear and control gear assemblies, drives, controls and interlocks, shall be subjected to a functional test to show that they are properly mounted, adjusted and installed in accordance with the relevant requirements of the IEC 60364. Protective devices shall be submitted to functional tests, if necessary, in order to check if they are properly installed and adjusted.

## 6.8 VERIFICATION OF VOLTAGE DROP.

Part 5 of IEC 60364 recommends that the voltage drop between the origin of the installation (usually the supply terminals) and the final circuit (operating at its rated current) does not exceed 4% of the nominal voltage of the supply.

A voltage drop greater than 4% may be accepted for motors during starting periods and for other equipment with high inrush currents.

To verify compliance with the above recommendation, part 6 of IEC 60364 recommends the following options:

- voltage drop may be evaluated measuring the circuit impedance by Loop tester;
- voltage drop may be evaluated using diagrams similar to the one shown in Fig 17.

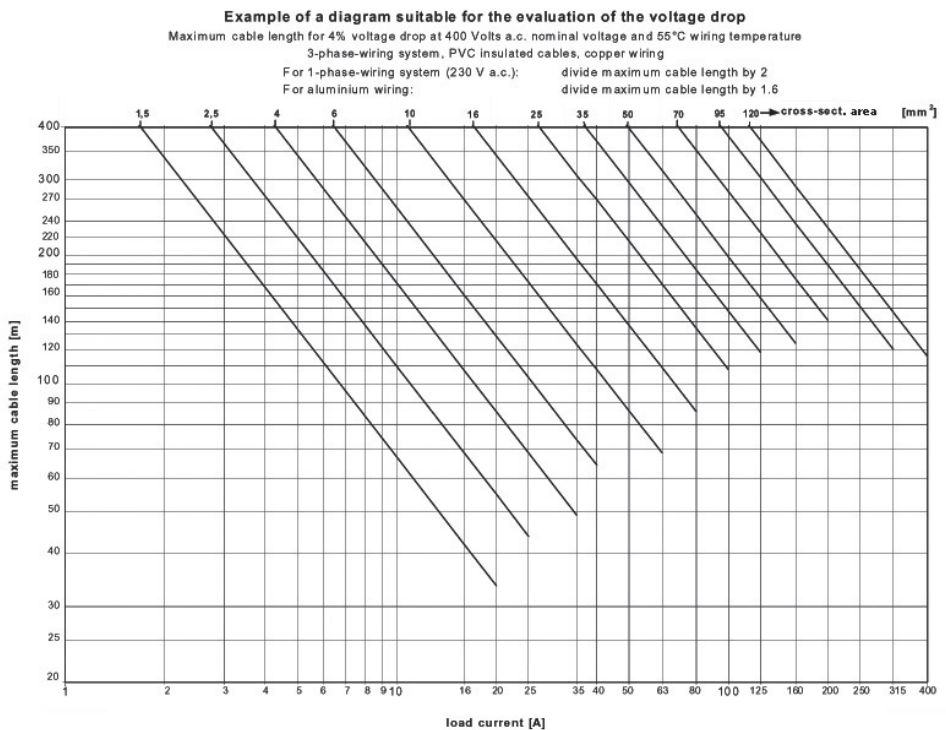

Fig 17

## **7. ELECTRICAL TESTING FOR PERIODIC VERIFICATION.**

Periodic Verification comprising a careful examination of the installation shall be carried out without dismantling or with partial dismantling as required, supplemented by appropriate tests as the Initial Verification including the requirements for disconnecting times in part 4-41 for RCDs are complied with by measurements.

Therefore the guidance information given in Chapters 5 and 6 of this pamphlet for Initial Verification is in principle valid also for Periodic Verification.

Periodic Verifications provide for the:

- a) safety of persons and livestock against the effects of electric shock and burn,
- b) protection against damage to property by fire and heat arising from an installation defect,
- c) confirmation that the installation is not damaged or deteriorated so as to impair safety,
- d) the identification of installation defects and departures from the requirements of IEC 60364 that may give rise to danger.

Also for electrical testing for Periodic Verification, the measuring instruments and monitoring equipment and methods shall be chosen in accordance with IEC 61557. If other measuring equipment is used, it shall provide no less degree of performance and safety.

### **7.1 FREQUENCY OF ELECTRICAL TESTING FOR PERIODIC VERIFICATION.**

The frequency of periodic verification of an installation shall be determined having regard to the type of installation and equipment, its use and operation, the frequency and quality of maintenance and the external influences to which it is subjected.

The maximum interval between periodic verifications may be laid down by legal or other national regulations.

The periodic report should provide for the person carrying out the periodic verification to recommend the interval to the next periodic verification.

The interval may be, for instance some years (e.g. 4 years), with the exception of the following cases:

- where a higher risk may exist and shorter periods may be required:
- working places or locations where risks of electric shock, fire or explosion exist due to degradation;
- working places or locations where both high and low voltage installations exist;
- communal facilities;
- construction sites;
- safety installations (e.g. emergency lightings).

For dwellings, longer periods (e.g. 10 years) may be appropriate. When occupancy of a dwelling has changed, a verification of the electrical installation is strongly recommended.

## **8. REPORTING FOR VERIFICATION.**

### *a) For Initial Verification*

Upon completion of the Initial Verification of a new installation or additions or alterations to an existing installation, an initial report shall be provided. Such documentation shall include details of the extent of the installation covered by the report, together with a record of the inspection and the results of testing.

Any defects or omissions revealed by the testing, shall be made good before the contractor declares that the installation complies with IEC 60364.

In the case of Initial Verification of alterations or additions to existing installations, the report may contain recommendations for repairs and improvements, as may be appropriate.

### *b) For Periodic Verification*

Upon completion of the Periodic Verification of an existing installation, a periodic report shall be provided.

Such documentation shall include details of those parts of the installation and limitations of the verification covered by the report, together with a record of the inspection, including any damage, deterioration, defects, dangerous conditions and the results of testing.

Fig 18 gives an example of Reporting of test results that might be used for Initial, and also Periodic Verification of installations, particularly suitable for domestic installations.











## 9. CROSS-TABLE TESTS / INSTRUMENTS.

The table below provides an easy cross reference between the tests required by IEC 60364/6 and the instruments which can perform such tests. It also facilitates the choice of instruments.

For further information and updates on instrument features please refer to Kyoritsu catalogue or visit Kyoritsu web site: <http://www.kew-ltd.co.jp>

<b>TESTS</b>  	<b>KYORITSU</b>						
	6016	6011A	6010B	6010A	6050	3131A 3132A	3133A
							
Continuity at 200 mA	●	●	●	●		●	
Insulation at 250V	●	●				●	
Insulation at 500V	●	●	●	●		●	
Insulation at 1000V	●	●	●			●	
Loop Impedance	●	●	●	●	●		
Fault Current	●	●			●		
RCD Trip Time	●	●	●	●	●		
RCD Trip Current	●		●		●		
Earth Resistance	●						
Phase Rotation	●						
Download results to Pc	●		●		●		

## INSTRUMENTS

3005A 3007A	3021 3023	5406A 5410	4102A 4105A	4116A	4118A 4120A	4200	8030 8031
							
●	●						
●	●						
●	●						
●	●						
				●	●		
					●		
		●					
		●					
			●			●	
							●

## **DISTRIBUTOR**

**Kyoritsu reserves the rights to change the information described in this guide without prior notice and without obligations.  
No part of this guide may be reproduced or utilised in any form or by any means without the permission from Kyoritsu.**

# **KYORITSU ELECTRICAL INSTRUMENTS WORKS, LTD**

**No. 5-20, Nakane 2 -Chome, Meguro-Ku, Tokyo 152-0031 Japan**  
**Phone: +81 3 3723-0131 Fax: +81 3 3723-0152**  
**URL: <http://www.kew-ltd.co.jp> E-mail: [info@kew-ltd.co.jp](mailto:info@kew-ltd.co.jp)**