

ELPA 047

Article number: 0470002

Description



- Flush-mounted staircase time switch, electronic
- Suitable for upgrades and new installation
- Switch or push button connectable, i.e. existing switches can be used (e.g. when updating)
- Zero-cross switching for relay-saving switching and high lamp loads
- Push button input with electronic overload protection
- Automatic 3 or 4 conductor detection (4 conductor with connection for floor lighting, 3 conductor no longer permitted for new systems)
- Extremely accurate
- Immediate secondary switching

Technical data

Operating voltage	230 V AC
Frequency	50 – 60 Hz
Installation type	Flush-mounted
Stand-by consumption	0,1 W
Glow lamp load	30 mA
Setting range time	0,5 – 20 min
Type of connection	3-/4-conductor
3/4 conductor	Automatic
Secondary switching	At once
Type of contact	NO contact
Opening width	< 3 mm (μ)
Switching output	Not potential-free (230 V)
Incandescent/halogen lamp load	1800 W
Fluorescent lamp load (conventional) lead-lag circuit	1200 VA
Fluorescent lamp load (conventional) parallel-corrected	580 VA, 54 μF
Energy saving lamps	13 x 7 W, 7 x 11 W, 5 x 15 W, 5 x 20 W, 4 x 23 W
Fluorescent lamp load (electronic ballast)	200 VA
Fluorescent lamp load (conventional) series-corrected	1200 VA
Fluorescent lamp load (conventional) not corrected	1200 VA
Switching capacity	6 AX (at 230 V AC, cos φ = 0.3), 10 A (at 230 V AC, cos φ = 1)
Test approval	VDE
Housing and insulation material	High-temperature resistant, self-extinguishing thermoplastic
Ambient temperature	-25 °C ... +45 °C
Protection class	II
Type of protection	IP 20

Scale drawings

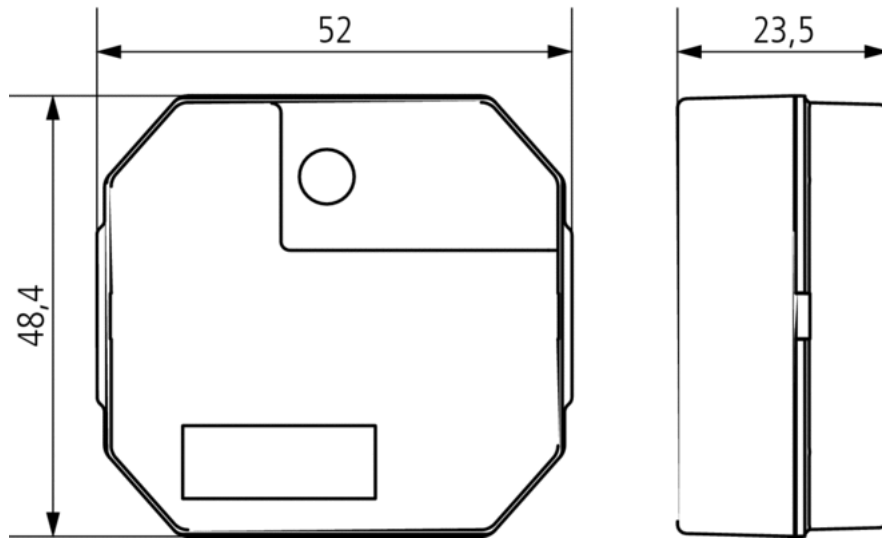

Connection example

